

BBP[®] 35/37 Label Printer

Quick Start Guide

Unpack Your Printer

The following items are included in the standard BBP[®]35/37 package:

- BBP[®]35/37 Label Printer
- Documentation CD including electronic Quick Start Guide, User's Manual, and web links
- Power Cord
- USB Type B Cable
- Quick Start Guide
- Cleaning Kit

Register Your Printer

Register your printer on-line at www.bradycorp.com/register and receive free product support and updates. (Refer to the back cover of this guide for technical support references.)

Brady Workstation

Create labels with your PC using Brady Workstation. Providing apps that feature built in regulations and standards, Brady Workstation helps you create signs and labels to keep your facility safe and compliant. Download Brady Workstation for free today at Workstation.BradylD.com.

External View

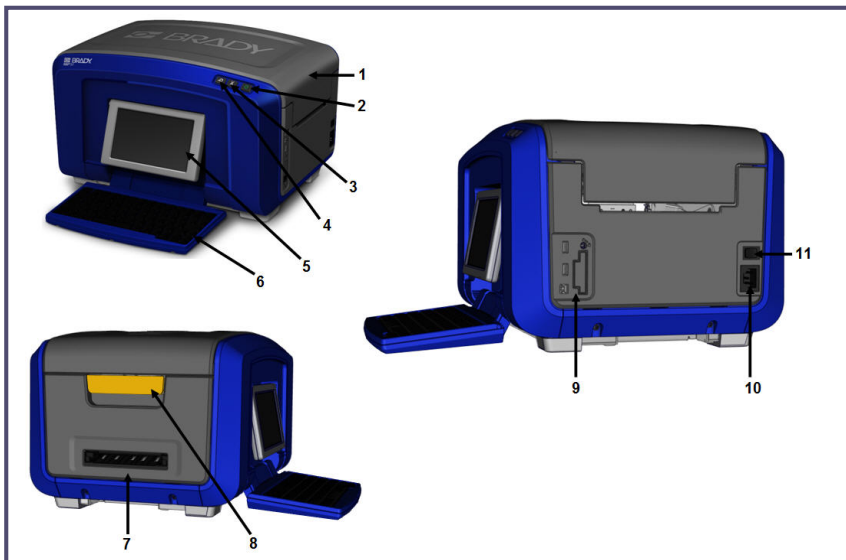

- | | | | |
|---|--------------------------|----|---|
| 1 | Cover | 7 | Label exit chute |
| 2 | Power button (green) | 8 | Cover release latch |
| 3 | Cut media button | 9 | USB, Expansion Ports and Brady Network Card |
| 4 | Feed media button | 10 | Power cord connection |
| 5 | Touch screen (flips out) | 11 | On/off switch |
| 6 | Keyboard (flips down) | | |

2 | Setting Up the Printer

Setting Up the Printer

Connecting Power

Before connecting power, be sure to remove any transportation protection from around the printhead and inside the enclosure cover.

1. Plug the power cord into the power cord connection port on the right side of the printer, then plug the other end of the cord into an AC power outlet.
2. Turn the power switch to ON.



Installing Ribbon

Illustrations on the inside of the cover show how to install the ribbon and label media (tape).

1. Open the cover by pulling up on the bottom of the yellow latch.

CAUTION

The cover pops open quickly. To ease the opening, place a hand on the cover as you release the latch.

2. With the cartridge tab on top, facing outward, place the exposed ribbon over the print head, then push the cartridge forward until it snaps into place.

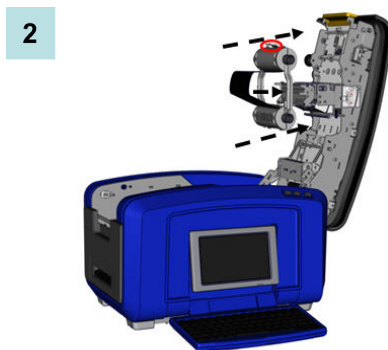
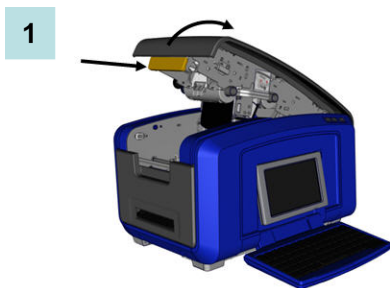

3. Turn the ribbon spindle knob to tighten the ribbon over the printhead.

3

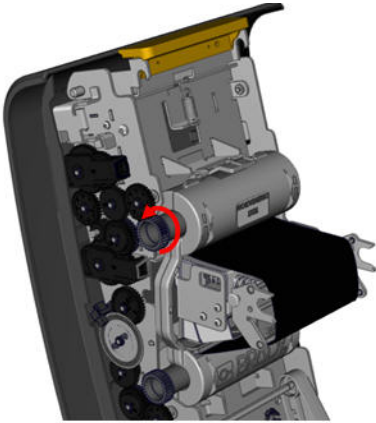

Installing Media (Tape)

4. Swing the media wiper bar up, out of the tape well.
5. Grasp the tape roll with the tape coming off the top of the roll and the touch cell on the left.

4

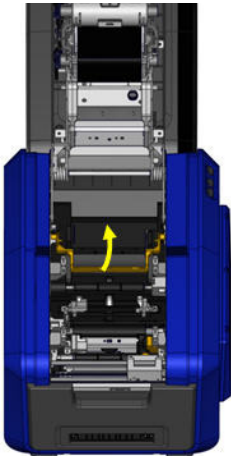

5



4 | Setting Up the Printer

- Drop the tape roll into the tape well, lining up the touch cell with the touch cell reader.
- Thread the label tape under and through the media guides, until the tape covers the black roller.

6

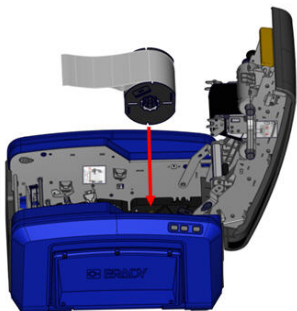

7

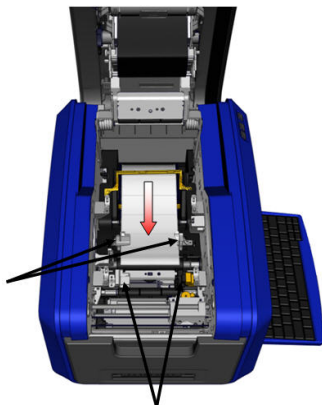

- Pinch the tape adjustment lever and slide the media guides until they are lined up with the edges of the tape liner.
- If using continuous media, lower the media bar.

8

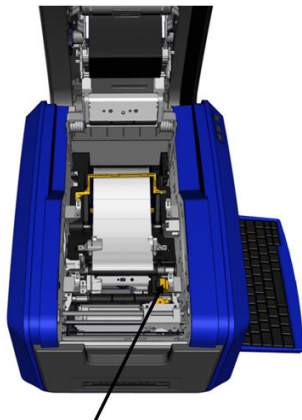

9

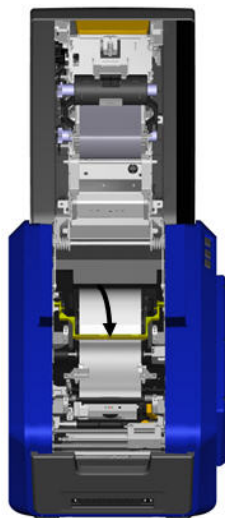

10. Close the cover.

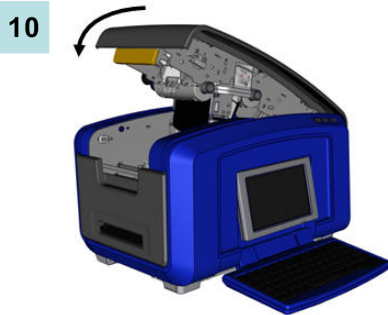

Power On

To turn the printer on or off:

1. Press the on/off switch on the side of the printer.



To turn the display on or off:

2. Press **Power**  .

Display Screen

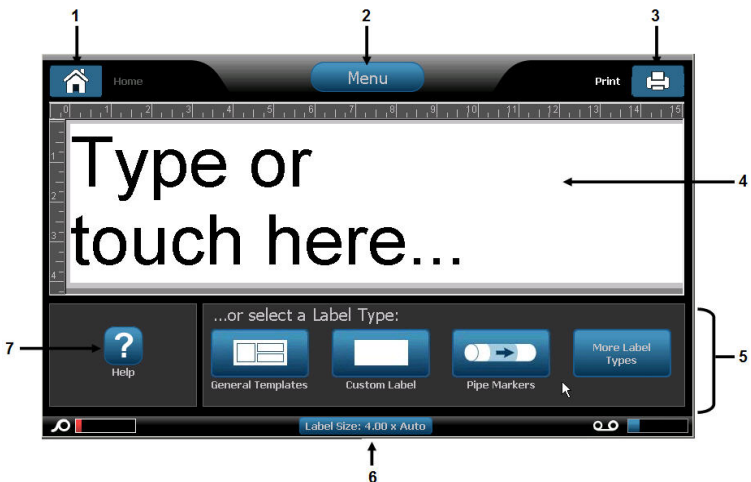
The BBP[®]35/37 printer uses touch screen technology. Using your finger, touch the desired option on the display screen.



Item #	Icon	Description
1		Home: Returns you to the <i>Home</i> page from anywhere in the application. When you are on the Home page, the button is grayed out.
2		Menu: Displays File, Label and System options.
3		Print: Displays the <i>Print</i> dialog box for printing the current label. If there is nothing in the Editor, the print button is grayed out.
4	Editor	Text or object entry area. Type, touch or select objects to display and edit in this area. The Editor also shows the color of the installed media and ribbon and displays rulers indicating the length and width of the label.
5	Control Panel	Primary area for selecting options for creating, editing and working with labels and objects. The panel changes depending on what option is selected. (Refer to the BBP [®] 35/37 user guide for complete instructions on all printer functions and features.)
6	Status Bar	Shows the current label size and indicators for the amount of media and ribbon remaining.
7	Tools Panel	Provides additional options for the specific tool selected. The Tools panel changes according to the object selected.

Menus

The main Menu button displays a list of sub-menus for different label or system functions. To display menu or sub-menu options:

1. Touch  to display the sub-menus.
2. In the pop-up list, touch the desired sub-menu option.

The selected sub-menu, in turn, can display another sub-menu.

3. Keep touching a sub-menu option until a dialog box displays.

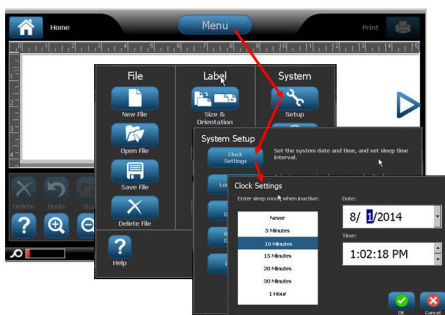

Menu Option	Description
File	Start a new file, open, save or delete a file.
Label	Set the size and orientation of the label, place a frame around the label, and select a template.
System	Configure clock settings, pick a language, set text, barcode, and printing defaults. Get information about your printer, import fonts and graphics from a PC through the use of an USB flash drive. Provides firmware upgrades through the PC or a USB flash drive. Also provides diagnostics for the printer.

Create a Text Label

Entering Text

When the printer is first turned on, you are presented with the Home page, displaying a blinking vertical bar (the cursor) and the message "Type or touch here..." Using the keyboard, begin entering text at the position of the cursor. The entered text automatically resizes to fill the label. If you want another line of text, press [ENTER] on the keyboard.



Edit Text

To edit text, touch the text you want to change, then touch any option in Tools or on the Text Control panel.



Printing a Label

To print a label:

1. Touch Print 

2. Touch Start Print 

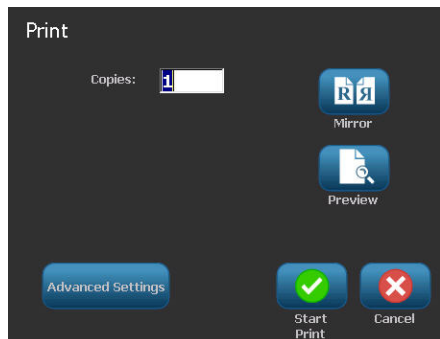

Brady Worldwide Inc.

6555 West Good Hope Road

Milwaukee, WI 53223 U.S.A.

Telephone: 414-358-6600 USA Domestic

Facsimile: 414-438-6958

Websites

For repair or technical assistance, go to your regional Brady Technical Support website:

- **United States:** www.bradyid.com
- **Europe:** www.bradyeurope.com
- **Asia Pacific:** www.bradycorp.com
- **Australia:** www.bradyaust.com.au
- **Canada:** www.bradycanada.ca
- **Latin American:** www.bradylatinamerica.com

Phone Numbers

- 1-800-643-8766 (USA)
- 1-800-263-6179 (Canada)
- 44 1295 228 205 (UK)
- 01 800 112 7239 (Mexico)
- 55 11 3604 7729 (Brazil)
- 001-866-748-4424 (Latin America)