



BBP[®]72-PLUS

LABEL PRINTER

USER MANUAL

Disclaimer

This manual is proprietary to Brady Worldwide, Inc. (hereafter “Brady”), and may be revised from time to time without notice. Brady disclaims any understanding to provide you with such revisions, if any.

This manual is copyrighted with all rights reserved. No portion of this manual may be copied or reproduced by any means without the prior written consent of Brady.

While every precaution has been taken in the preparation of this document, Brady assumes no liability to any party for any loss or damage caused by errors or omissions or by statements resulting from negligence, accident, or any other cause. Brady further assumes no liability arising out of the application or use of any product or system described, herein; nor any liability for incidental or consequential damages arising from the use of this document. Brady disclaims all warranties of merchantability of fitness for a particular purpose.

Brady reserves the right to make changes without further notice to any product or system described herein to improve reliability, function, or design.

Trademarks

BBP72-Plus Label Printer is a trademark of Brady Worldwide, Inc.

Microsoft, Windows, Excel, Access and SQL Server are registered trademarks of Microsoft Corporation.

All brand or product names referenced in this manual are trademarks (™) or registered trademarks (®) of their respective companies or organizations.

Brady Warranty

Our products are sold with the understanding that the buyer will test them in actual use and determine for themselves the adaptability to their intended uses. Brady warrants to the buyer that its products are free from defects in material and workmanship, but limits its obligation under this warranty to replacement of the product shown to Brady’s satisfaction to have been defective at the time Brady sold it. This warranty does not extend to any persons obtaining the product from the buyer.

THIS WARRANTY IS IN LIEU OF ANY OTHER WARRANTY, EXPRESS OR IMPLIED, INCLUDING, BUT NOT LIMITED TO, ANY IMPLIED WARRANTY OF MERCHANTABILITY OR FITNESS FOR A PARTICULAR PURPOSE, AND OF ANY OTHER OBLIGATIONS OR LIABILITY ON BRADY’S PART. UNDER NO CIRCUMSTANCES WILL BRADY BE LIABLE FOR ANY LOSS, DAMAGE, EXPENSE OR CONSEQUENTIAL DAMAGES OF ANY KIND ARISING IN CONNECTION WITH THE USE, OR INABILITY TO USE, BRADY’S PRODUCTS.

Registration Information

To register your printer go to: bradycorp.com/register

© 2023 Brady Worldwide, Inc. All Rights Reserved.

Y5235449

Revision A

Brady Worldwide, Inc.

6555 West Good Hope Road

Milwaukee, WI 53223

bradyid.com

Further documentation

Configuration Manual

▷ www.bradyid.com/bbp72plus 

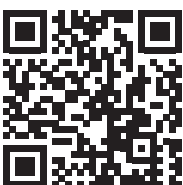

Table of Contents

1	Introduction	4
1.1	Instructions.....	4
1.2	Intended Use.....	4
1.3	Safety Instructions.....	5
1.4	Environment.....	5
2	Installation	6
2.1	Device Overview	6
2.2	Unpacking and Setting-up the Printer	8
2.3	Connecting the Device	8
2.3.1	Connecting to the Power Supply	8
2.3.2	Connecting to a Computer or Computer Network	8
2.4	Switching on the Device.....	8
3	Touchscreen Display	9
3.1	Start Screen	9
3.2	Navigation in the Menu	11
4	Loading Material.....	12
4.1	Loading Media from Roll	12
4.1.1	Positioning the Media Roll on the Roll Retainer	12
4.1.2	Inserting Media into the Print Mechanics.....	13
4.1.3	Setting the Label Sensor	14
4.1.4	Setting the Head Locking Systems.....	14
4.2	Loading Transfer Ribbon.....	15
4.3	Setting the Feed Path of the Transfer Ribbon.....	16
5	Operation	17
5.1	Printhead Protection.....	17
5.2	Designing the Print Image.....	17
5.3	Identical Images on Both Sides.....	17
5.4	Single Side Printing.....	17
5.5	Ribbon Saving.....	17
5.6	Avoiding Loss of Material	18
5.7	Avoiding Loss of Data	19
5.8	Cutting and Perforating	19
6	Cleaning.....	20
6.1	Cleaning Information.....	20
6.2	Cleaning the Print Rollers	20
6.3	Cleaning the Printheads.....	20
6.4	Cleaning the Label Sensor.....	21
7	Fault Correction	22
7.1	Error Display	22
7.2	Error Messages and Fault Correction	23
7.3	Problem Solution.....	25
8	Media	26
8.1	Media Dimensions.....	26
8.2	Device Dimensions	27
8.3	Reflex Mark Dimensions	28
8.4	Cut-out Mark Dimensions.....	29
9	Regulatory Compliance.....	30
9.1	Agency Compliance and Approvals	30
10	Index.....	32

1.1 Instructions

Important information and instructions in this documentation are designated as follows:

**Danger!**

Draws attention to an exceptionally great, imminent danger to your health or life due to hazardous voltages.

**Danger!**

Draws attention to a danger with high risk which, if not avoided, may result in death or serious injury.

**Warning!**

Draws attention to a danger with medium risk which, if not avoided, may result in death or serious injury.

**Caution!**

Draws attention to a danger with low risk which, if not avoided, may result in minor or moderate injury.

**Attention!**

Draws attention to potential risks of property damage or loss of quality.

**Note!**

Advices to make work routine easier or on important steps to be carried out.

**Environment!**

Gives you tips on protecting the environment.



Handling instruction



Reference to section, position, illustration number or document.



Option (accessories, peripheral equipment, special fittings).

Time

Information in the display.

1.2 Intended Use

- The device is manufactured in accordance with the current technological status and the recognized safety rules. However, danger to the life and limb of the user or third parties and/or damage to the device and other tangible assets can arise during use.
- The device may only be used for its intended purpose and if it is in perfect working order, and it must be used with regard to safety and dangers as stated in the operating manual.
- The device printer is intended exclusively for printing suitable materials. Any other use or use going beyond this shall be regarded as improper use. The manufacturer/supplier shall not be liable for damage resulting from unauthorized use; the user shall bear the risk alone.
- Usage for the intended purpose also includes complying with this manual.
- This equipment is not intended for use by children.

1.3 Safety Instructions

- The device is configured for voltages of 100 to 240 V AC. It only has to be plugged into a grounded socket.
- Only connect the device to other devices which have a protective low voltage.
- Switch off all affected devices (computer, printer, accessories) before connecting or disconnecting.
- The device may only be used in a dry environment, do not expose it to moisture (sprays of water, mists, etc.).
- Do not use the device in an explosive atmosphere.
- Do not use the device close to high-voltage power lines.
- If the device is operated with the cover open, ensure that people’s clothing, hair, jewelry etc. do not come into contact with the exposed rotating parts.
- The device or parts of it can become hot while printing. Do not touch during operation, and allow to cool down before changing material and before disassembly.
- Risk of crushing when closing the cover. Touch the cover at the outside only. Do not reach into the swivel range of the cover.
- Perform only those actions described in this operating manual.
Work going beyond this may only be performed by trained personnel or service technicians.
- Unauthorized interference with electronic modules or their software can cause malfunctions.
- Other unauthorized work on or modifications to the device can also endanger operational safety.
- Always have service work done in a qualified workshop, where the personnel have the technical knowledge and tools required to do the necessary work.
- There are various warning stickers on the device. They draw your attention to dangers.
Warning stickers must therefore not be removed, as then you and other people cannot be aware of dangers and may be injured.
- The maximum sound pressure level is less than 70 dB(A).



Danger!
Danger to life and limb from power supply.
 ► Do not open the device casing.



Warning!
This is a class A product. In a domestic environment this product may cause radio interference in which case the user may be required to take adequate measures.

1.4 Environment



Obsolete devices contain valuable recyclable materials that should be sent for recycling.

- Send to suitable collection points, separately from residual waste.

The modular construction of the printer enables it to be easily disassembled into its component parts.

- Send the parts for recycling.



The electronic circuit board of the device is equipped with a lithium battery.

- Take old batteries to collection boxes in shops or public waste disposal centers.

2.1 Device Overview

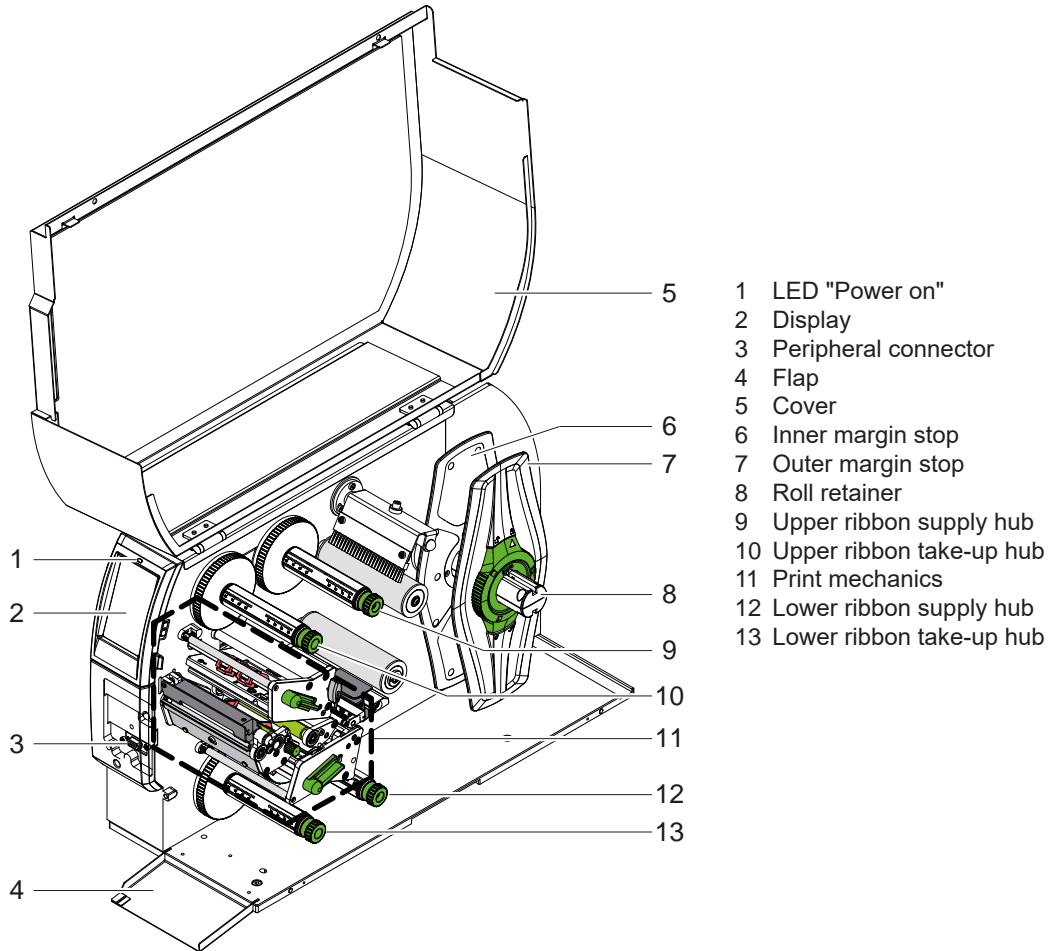

Figure 1 Overview

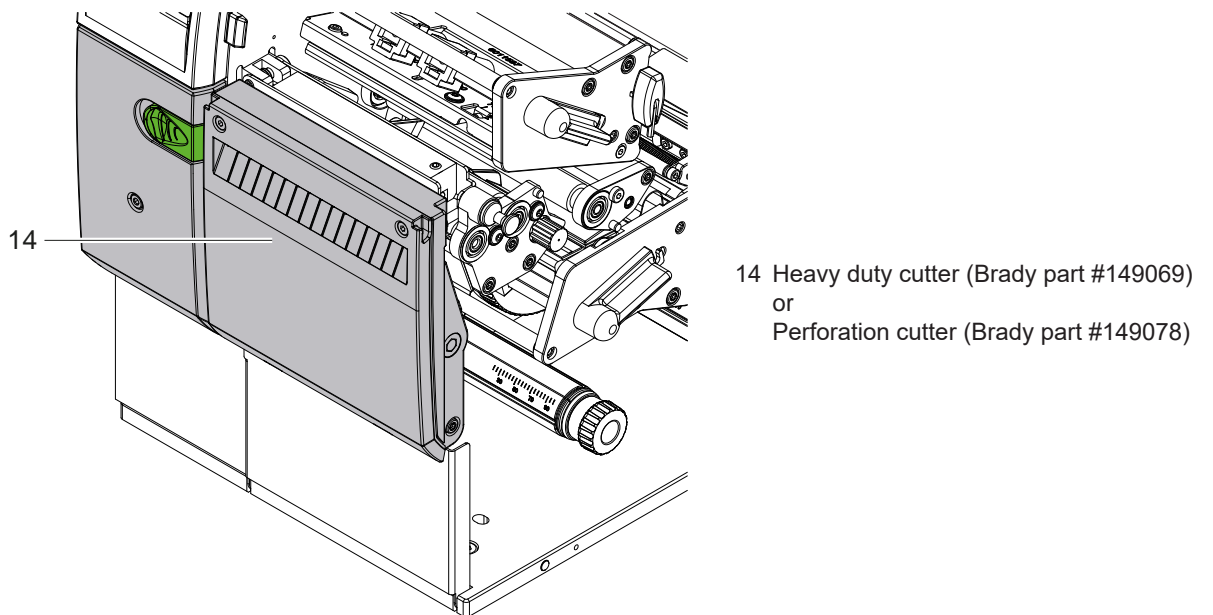

Figure 2 Version with cutter

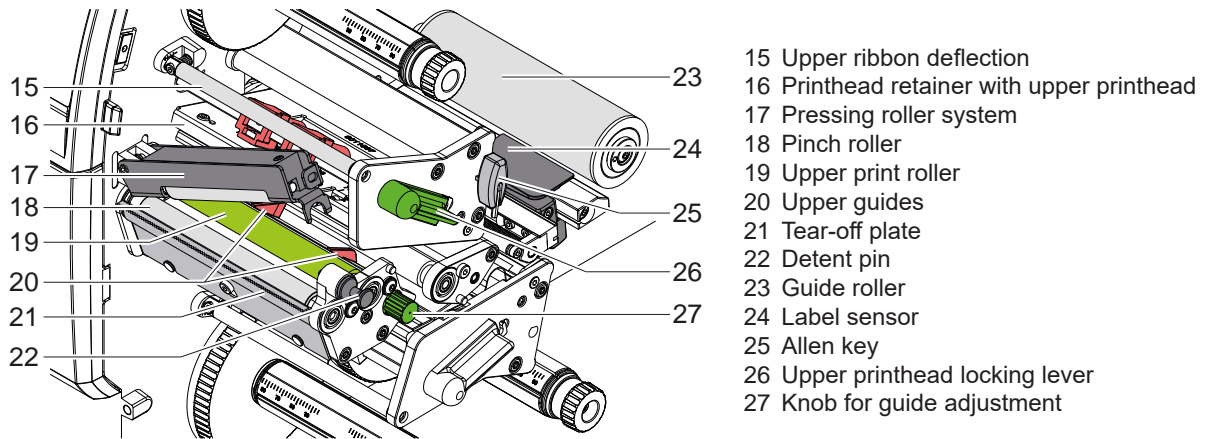

Figure 3 Print mechanics - upper print unit

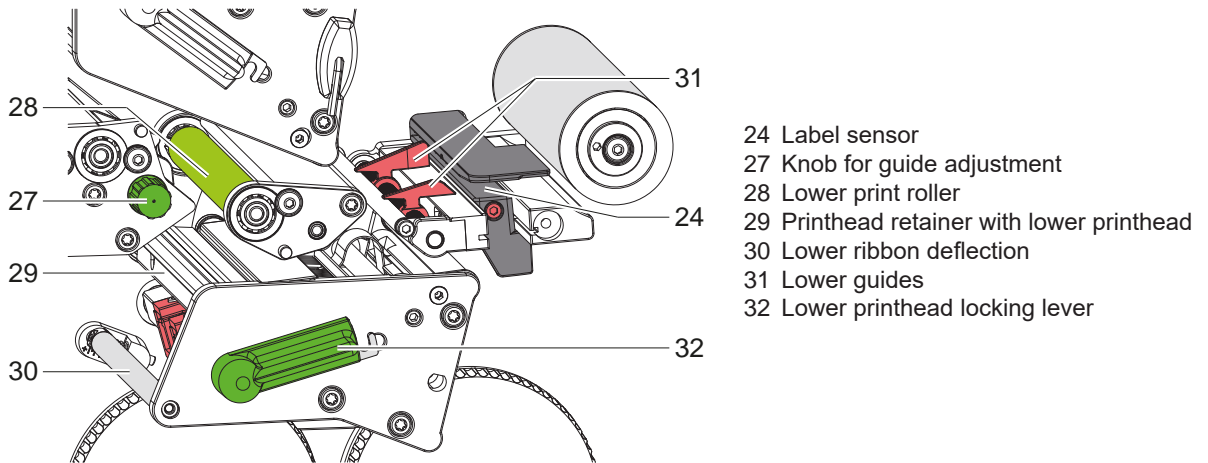

Figure 4 Print mechanics - lower print unit

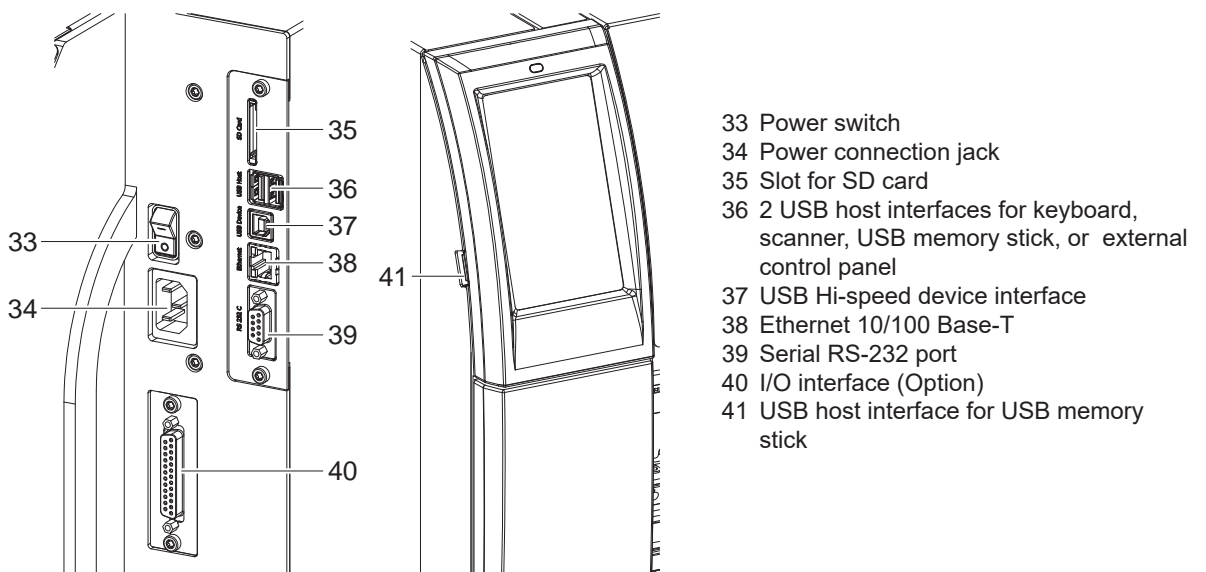

Figure 5 Connections

2.2 Unpacking and Setting-up the Printer

- ▶ Lift the label printer out of the box.
- ▶ Check label printer for damage which may have occurred during transport.
- ▶ Set up printer on a level surface.
- ▶ Remove foam transportation safeguards near the printhead.
- ▶ Check delivery for completeness.

Contents of delivery:

- Label printer
- Power cable
- USB cable
- Instructions



Note!

Please keep the original packaging in case the printer must be returned.



Attention!

The device and printing materials will be damaged by moisture and wetness.

- ▶ Set up label printers only in dry locations protected from splash water.

2.3 Connecting the Device

The standard available interfaces and connectors are shown in Figure 5.

2.3.1 Connecting to the Power Supply

The printer is equipped with a wide area power unit. The device can be operated with a supply voltage of 230 V~/50 Hz or 115 V~/60 Hz without adjustment.

1. Check that the device is switched off.
2. Plug the power cable into the power connection socket (34).
3. Plug the power cable into a grounded socket.

2.3.2 Connecting to a Computer or Computer Network



Attention!

Loss of material!

The RS-232 interface is unsuitable for fast transmission of changing data ▶ 5.6 on page 18.

- ▶ Use USB or Ethernet interface for print operation.



Attention!

Inadequate or no grounding can cause malfunctions during operations.

Ensure that all computers and cables connected to the label printer are grounded.

- ▶ Connect the label printer to a computer or network by a suitable cable.

For details of the configuration of the individual interfaces ▶ Configuration Manual.

2.4 Switching on the Device

When all connections have been made:

- ▶ Switch the printer on at the power switch (34).
The printer performs a system test, and then shows *Ready* in the display (2).

3 Touchscreen Display

The user can control the operation of the printer with the control panel, for example:

- Issuing, interrupting, continuing and canceling print jobs,
- Setting printing parameters, e.g. heat level of the printhead, print speed, interface configuration, language and time of day (▷ Configuration Manual),
- Control stand-alone operation with a memory module (▷ Configuration Manual),
- Update the firmware (▷ Configuration Manual).

Many functions and settings can also be controlled by software applications or by direct programming with a computer using the printer's own commands.

Settings made on the touchscreen display make the basic settings of the label printer.



Note!

It is advantageous, whenever possible, to make adaptations to various print jobs in the software.

3.1 Start Screen

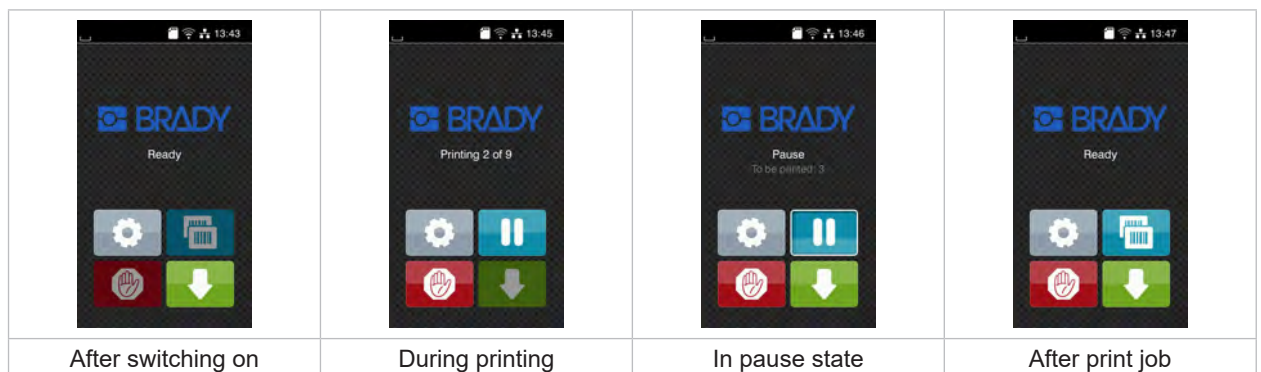

Figure 6 Start screen

The touchscreen display is operated directly by touch:

- To open a menu or select a menu item lightly touch the corresponding symbol.
- To scroll in lists slide finger up or down on the display.

	Open the menu		Repeat the last printed label
	Interrupt the print job		Short touch: Cancel the current print job Long touch: Cancel all print jobs
	Continue the print job		Feed a blank label

Table 1 Symbols on the start screen



Note!

Inactive symbols are shaded.

With special software or hardware configurations additional symbols appear on the start screen:

		
Printing on demand without print job	Printing on demand within print job	Direct cut with cutter installed

Figure 7 Optional symbols on the start screen

	Release printing of a single label within a print job including peeling-off, cutting...		Release a direct cut without media feed
---	---	---	---

Table 2 Optional symbols on the start screen

In the headline several information are displayed as widgets depending on the configuration:

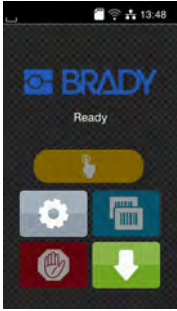
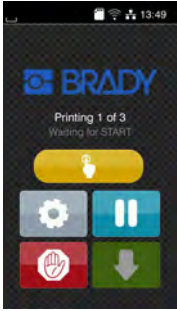
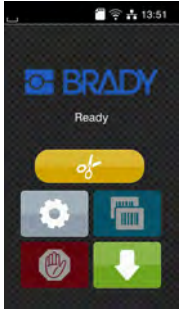
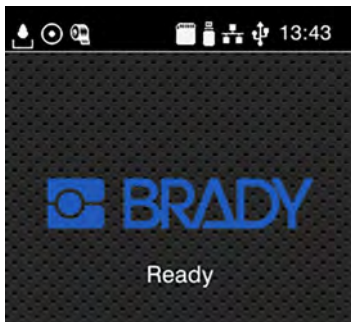

Figure 8 Widgets in the start screen









	Displays the current data transfer in the form of a falling drop.
	The <i>Save data stream</i> function is active ▷ Configuration manual All received data are stored in a .lbl file.
	Warning ribbon end ▷ Configuration manual The remaining diameter of the ribbon supply roll undershoots the set value.
	SD card installed
	USB memory installed
	Ethernet connection active
	USB connection active
	abc program active
	Clock time

Table 3 Widgets in the start screen

3.2 Navigation in the Menu

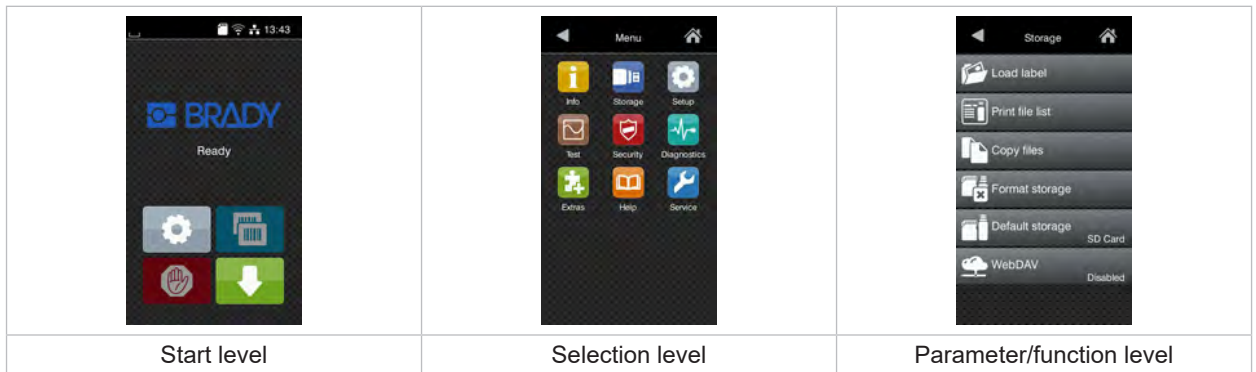

Figure 9 Menu levels

- ▶ To open the menu select on the start screen.
- ▶ Select a theme in the selection level. Several themes have substructures again with selection levels. To return from the current level to the upper one select . To leave the menu select .
- ▶ Continue the selection until the parameter/function level is reached.
- ▶ Start a function. The will carry out the function possibly after a preparing dialogue.
 - or -
 - Select a parameter to set. The setup possibilities are depending from the parameter type.

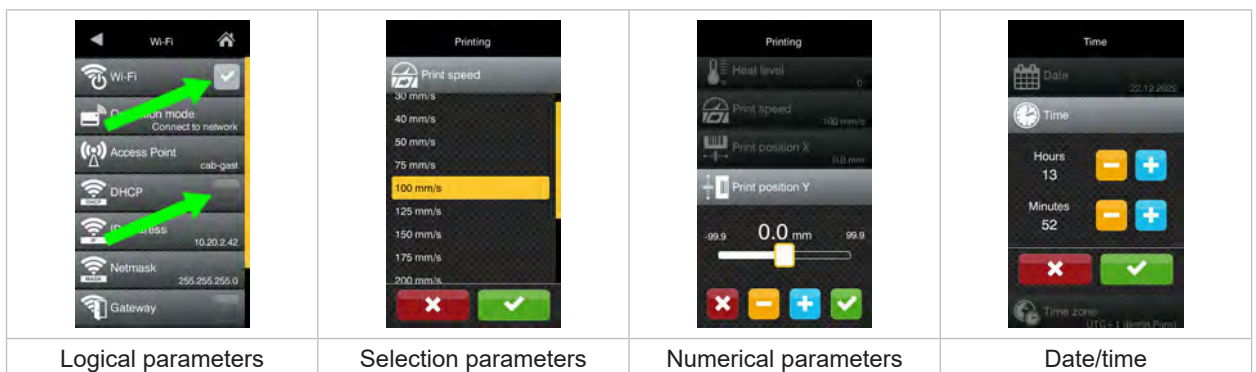

Figure 10 Samples for parameter setting

	Scroll bar for rough value setting
	Decreasing the value step-by-step
	Increasing the value step-by-step
	Return without saving the setting
	Return with saving the setting
	Parameter is disabled, touching enables the parameter
	Parameter is enabled, touching disables the parameter

Table 4 Buttons for parameter setting



Note!

For adjustments and simple installation work, use the accompanying Allen key located in the upper section of the print unit. No other tools are required for the work described here.

4.1 Loading Media from Roll

4.1.1 Positioning the Media Roll on the Roll Retainer

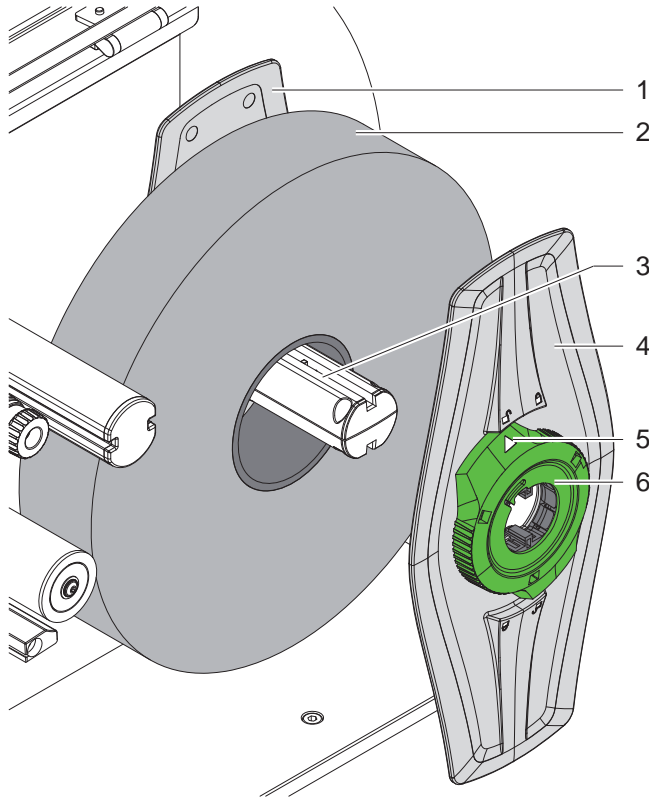



Figure 11 Loading media from roll

1. Open cover.
2. Turn ring (6) counterclockwise, so that the arrow (5) points to the symbol , and thus release the margin stop (4).
3. Remove the margin stop (4) from the roll retainer (3).
4. Load label roll (2) on the roll retainer (3).
5. Re-mount the margin stop (4) onto the roll retainer (3). Push the margin stop (4) until both margin stops (1,4) touch the label roll (2) and a clear resistance is encountered.
6. Turn ring (6) clockwise, so that the arrow (5) points to the symbol , and thus fix the margin stop (4) on the roll retainer.

4 Loading Material

4.1.2 Inserting Media into the Print Mechanics

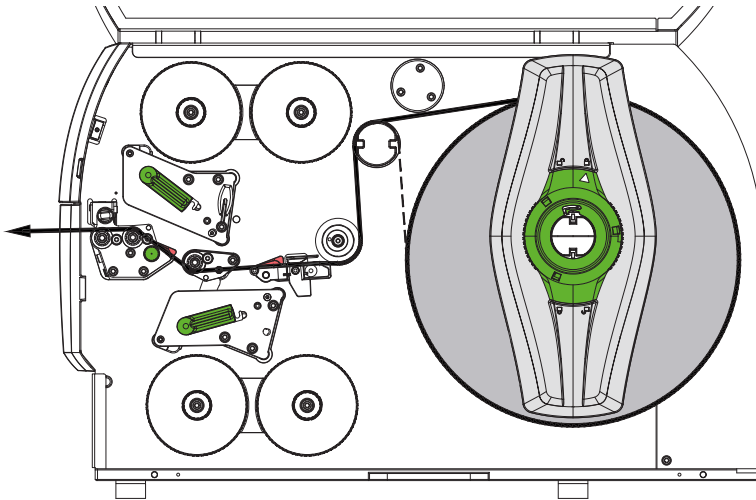

Figure 12 Media feed path

1. Unroll a longer media strip. Guide the media strip to the print mechanics as shown in Figure 12.
2. Pull the detent pin (6). The pressing roller system (1) will swing upwards.
3. Turn lever (10) counterclockwise and lever (11) clockwise to lift both printheads.
4. Swivel the brush (8) from the roller (9).
5. Move guides (5) apart with the knob (7) until the media can pass between them.
6. Guide media strip through the print mechanics as shown in Figure 13 to the pinch roller (2) and place the strip between the guides (9).
7. * Devices with cutter: Slide the knob (3) to the left to fold down the cutter unit (4). Guide the media through the cutter blades and fold up and lock the cutter.
8. Move the guides against the edges of the media by turning the knob (7).
9. Fix the media by closing the upper printhead.
10. Pull the detent pin (6). Push the pressing roller system (1) downwards and lock it with the detent pin.
11. Turn the media roll against the feed direction to tighten the media.
12. Close the lower printhead.
13. Swivel the brush (8) to the roller (9).



Attention!

► For single side printing (▷ 5.4 on page 17) do not close the lower printhead.

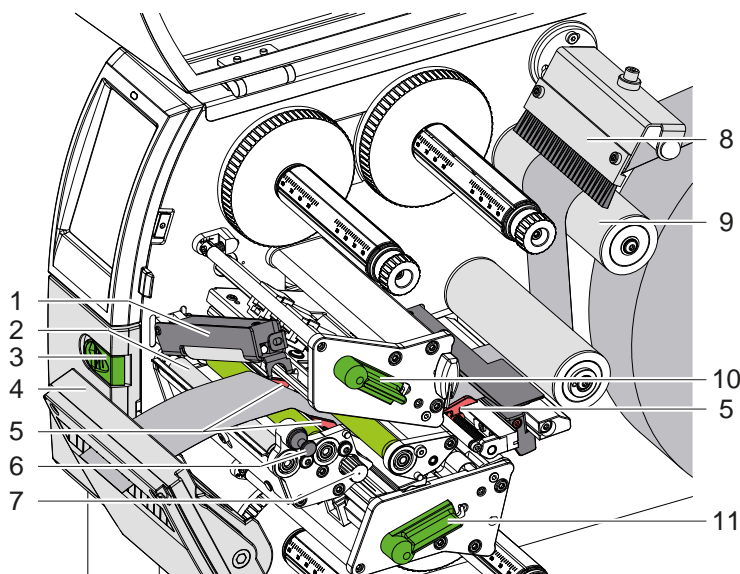

Figure 13 Inserting media into the print mechanics

4.1.3 Setting the Label Sensor

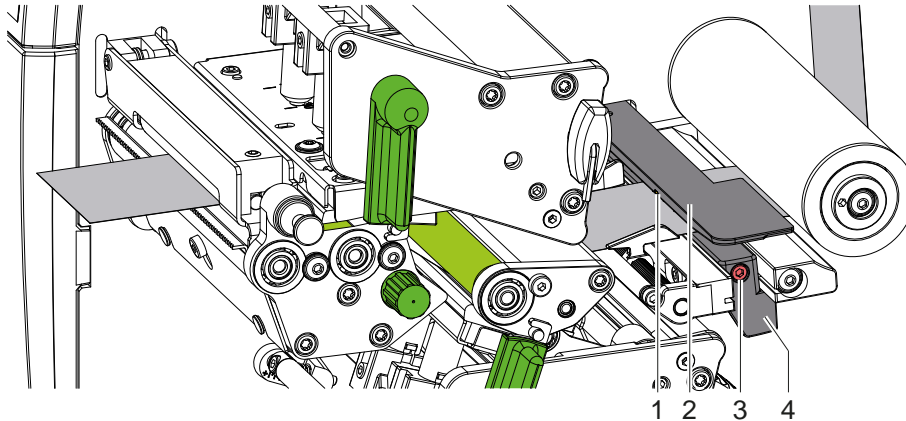

Figure 14 Setting the label sensor

The label sensor can be shifted perpendicular to the direction of paper flow for adaptation to the media. The sensor unit (2) of the label sensor is marked with an indentation in the label sensor retainer. When the printer is switched on, a yellow LED illuminates the sensor position.

- ▶ Loosen screw (3).
- ▶ Position label sensor with tab (4) in such a way that the sensor (1) can detect the label gap or a reflex or perforation mark.
- or, if the labels deviate from a rectangular shape, -
- ▶ Align label sensor using the tab (4) with the front edge of the label in the direction of paper flow.
- ▶ Tighten screw (3).

4.1.4 Setting the Head Locking Systems

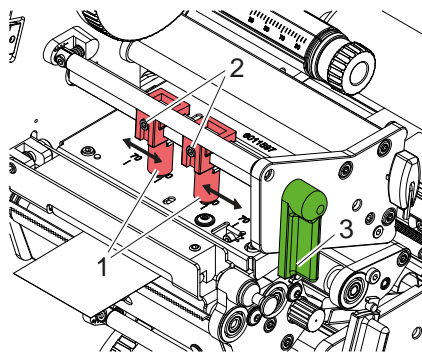

Figure 15 Setting the upper head locking system

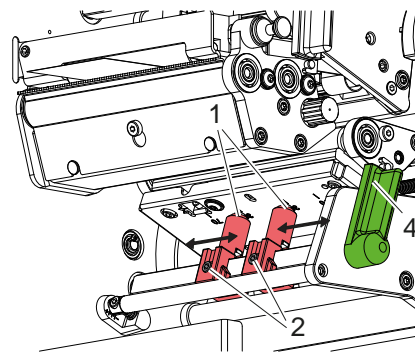

Figure 16 Setting the lower head locking system

The printheads are pushed on via two plungers (1). In the basic setting the plungers are set in the middle of the printhead retainer. This setting can be used for the most applications.

If the print density decreases in the outer areas when using very large media, the plungers can be displaced :

1. Turn lever (3) clockwise and the lever (4) counterclockwise to lock the printheads.
2. Loosen threaded pins (2) at the plungers (1) with Allen key.
3. Displace plungers symmetrically as necessary maximal to the scale value 70.
4. Tighten the threaded pins (2).

4.2 Loading Transfer Ribbon



Note!

With direct thermal printing, do not load a transfer ribbon; if one has already been loaded, remove it.

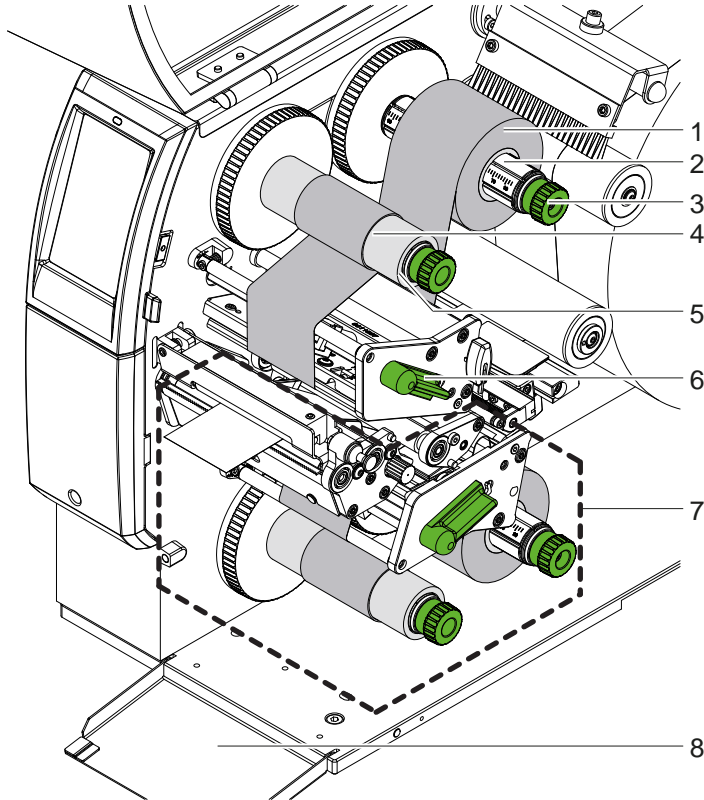

Figure 17 Load transfer ribbon

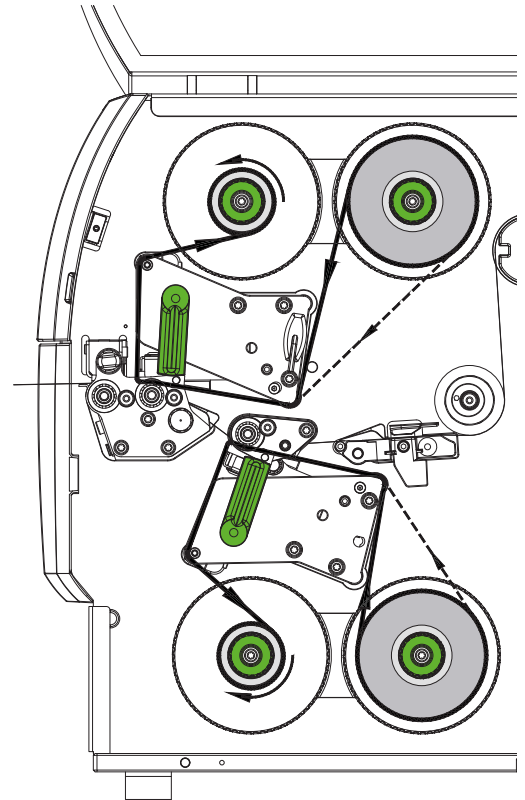

Figure 18 Transfer ribbon feed path

1. Clean the printheads before loading the transfer ribbon (▷ 6.3 on page 20).
2. Turn the lever (6) counterclockwise to lift the upper printhead.
3. Slide a transfer ribbon roll (1) onto the ribbon supply hub (3) so that the color coating of the ribbon faces downward when being unwound.
4. Position the ribbon roll (1) in such a way that both ends of the roll show identical scale values.
5. Hold transfer ribbon roll (1) firmly and turn knob (3) on ribbon supply hub counterclockwise until the transfer ribbon roll is secured.



Note!

To rewind the transfer ribbon use a core with a width between the width of the supply roll and 115 mm.

6. Slide suitable transfer ribbon core (4) onto the transfer ribbon take-up hub (5). Position and secure it in the same way like the supply roll.
7. Guide transfer ribbon through the print unit as shown in Figure 18.
8. Secure starting end of transfer ribbon to middle of the transfer ribbon core (4) with adhesive tape. Ensure counterclockwise rotation direction of the transfer ribbon take-up hub.
9. Turn transfer ribbon take-up hub (5) counterclockwise to smooth out the feed path of the transfer ribbon.
10. Turn lever (6) clockwise to lock the printhead.

11. Open the flap (8) and load transfer ribbon to the lower print unit (7) in a similar way. All previous statements of direction apply contrariwise excepting the turning of the knobs.



Note!

For single side printing (▷ 5.4 on page 17) do not insert ribbon into the lower print unit.

4.3 Setting the Feed Path of the Transfer Ribbon

Transfer ribbon wrinkling can lead to print image errors. Transfer ribbon deflection can be adjusted so as to prevent wrinkles.

Note!
The adjustment is best carried out during printing.

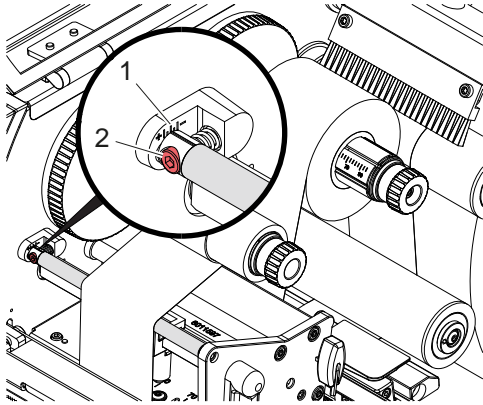

Figure 19 Setting the upper ribbon feed path

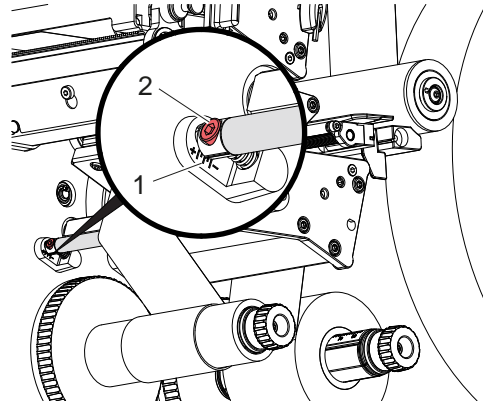

Figure 20 Setting the lower ribbon feed path

1. Read current setting on the scale (1) and record if necessary.
2. Turn screw (2) with Allen key and observe the behavior of the ribbon.
In the + direction, the inner edge of the ribbon is tightened, and the outer edge is tightened in the - direction.

5.1 Printhead Protection



Attention!

Printhead damage caused by improper handling!

- ▶ Do not touch the heating elements of the printheads with the fingers or sharp objects.
- ▶ Ensure that the material is clean.
- ▶ Ensure that the material surfaces are smooth. Rough material act like emery paper and reduce the service life of the printhead.
- ▶ Print with the lowest possible printhead temperature.

The printer is ready for operation when all connections have been made and labels and, if applicable, the transfer ribbon have been loaded.

5.2 Designing the Print Image

- ▶ Define the double material width as label width.
- ▶ Place the information for one print side at x-coordinates between 0 and the material width.
- ▶ Place the information for the other side at x-coordinates between the single and the double material width.

5.3 Identical Images on Both Sides

- ▶ Define the single material width as label width.
- ▶ Place the information.
- ▶ Activate in the printer driver menu **General > Print Settings > Page Setting >** the setting "**Top side same as bottom**".
or
- ▶ Activate in cablabel S3 under **Configuration > Machine > X-Series** the setting "**Lower side same as upper side**" aktivieren.

5.4 Single Side Printing

The lower printhead can be switched off. Therefore is it possible to print labels in a similar way as in on side printers.

- ▶ Activate the parameter *Setup > Printing > Disable lower head*.
- ▶ Unlock the lower printhead.
- ▶ Remove the ribbon from the lower print unit.
- ▶ In Brady Workstation, under Print Settings select one side to print and click the box next to "Lower Printhead is disabled on printer".
- ▶ If a Syntax error is displayed on the printer, either the printer or Brady Workstation was not set up correctly.

5.5 Ribbon Saving

If there is no information to print during a longer label feed, in the lower print unit the printhead will be lifted, and the transfer ribbon will be paused from feeding. This will reduce the ribbon consumption. The minimum length for ribbon saving is defined in the firmware and depends on the print speed.

The ribbon saver can permanently be activated in the printer configuration (▷ Configuration Manual) or job-oriented by the software.

5.6 Avoiding Loss of Material



Attention!

Loss of material!

The print images for the upper and the lower side of one label/section are printed at two different places in the media feed.

Therefore every interruption of the continuous print process has the following consequences :

- Material already printed at the lower side will be fed to the upper printhead to complete the print of the label/section, but the following media will not be printed at the lower side.
- A media backfeed to the lower printhead is not allowed due to the reliability of the media transport.
- Following blank sections in the media strip are generated, which cannot be used.
- For operation with cutter the length of the blank section is at least 110 mm for continuous material. For structured media where the print image has to be synchronized to the media transport the loss of material can reach a length of more than 300 mm.

To minimize the loss of material it is necessary to avoid interruptions of the continuous print process.

- ▶ Interrupt the print process only if it is absolutely necessary.
- ▶ Avoid print jobs with a small amount of labels/sections, especially single prints.
- ▶ Avoid predictable error situations ▶ 5.7 on page 19.
If errors occur the loss of material is particular high. Besides the blank section also material must be rejected which is partly printed.

Print Optimization

To minimize the loss of material the parameter *Setup > Printing > Double print optim.* can be activated.

With this setting a print job will not be carried out immediately till the end. The printer stops at a position, where a following print job could be started without blank labels. In this position the printer waits for the next job. After the job is received the previous job will be completed and the new job will be started without blank labels between the jobs. If no further job can be awaited the current job can be completed with *Finalize print job*.

Optimization of the Data Transfer

If sequent labels/sections contain differing information, the internal preparation of the second sections must be completed before the printing by the lower printhead for the first section has been finished !

Otherwise the first section will be fed to the upper printhead to complete the print without printing the next section at the lower side. The print of the second section begins only after completion of the first section.

Therefore it is necessary to minimize the data to be transferred. i.e. to avoid transferring complete label descriptions and to transfer the changing data only:



Note!

Therefore the parameter "Software optimization" in the printer driver is activated permanently. With cablabel S3 the data transmission will be optimized automatically.

- ▶ For direct programming use the replace command **R** for changing data.



Attention!

Loss of material!

The RS-232 interface is unsuitable for fast transmission of changing data.

- ▶ Use USB or Ethernet interface for print operation.

5.7 Avoiding Loss of Data



Attention!

Loss of data!

When correctable errors occur labels/sections which are already printed by the lower printhead but not are completed by the upper printhead cannot be repeated after error correction. The data of those sections are lost for the printer.

- ▶ Avoid predictable error situations.
- ▶ To avoid the errors "Out of paper" or "Out of ribbon" switch the printer to the Pause state before the material runs out. Continue the print process by pressing the pause key after re-loading material. That way the data are saved.

Pause on Media Low

The error "Out of ribbon" can be avoided automatically with the integrated ribbon low warning :

- ▶ Activate the parameter *Setup > Ribbon > Pause on warning*.
 - ▶ Set the rest diameter of the ribbon supply roll with the parameter *Setup > Ribbon > Warn level ribbon* to e.g. 35 mm.
- If the diameter of the ribbon roll falls below the set value the automatically switches to the *Pause* state.

5.8 Cutting and Perforating

* For devices with cutter only.

- ▶ Activate the commands for perforation or cut-off in the software.
For direct programming use the following commands:

C p Perforation command

C Cut-off command

Both commands may be combined, but C p has a lower priority.

- ▶ Using the sequence :
C 3
C p
the material will be perforated two times and afterwards cut off.
- ▶ Configure the cut parameters



Note!

The cut parameters are only accessible with cutter installed.



Attention!

In several label software solutions the perforation command C p is not implemented. Perforating material via such a software is not possible.

- ▶ Adapt the perforation level to the media.
For direct programming use the following command :

O Cn n...Value between 0.0 and 10.0



Note!

If the label software has no setting for the perforation level, i.e. O Cn is not implemented, the adjustment also may be done using the printer setup

To guarantee the correct length of the first label a cut prior print job is required :

- ▶ Activate in the printer driver menu **General > Print Settings > Accessories Options > [Cutter]** the setting "Cut before print job".
or
- ▶ Activate in cablabel S3 under **Options > Connected peripheral > [Cutter]** the setting "Cut before print job".
or
- ▶ For direct programming use the command **C s**.

6.1 Cleaning Information



Danger!

Risk of death via electric shock!

- ▶ **Disconnect the printer from the power supply before performing any maintenance work.**

The transfer printer requires very little maintenance.

It is important to clean the thermal printheads regularly. This guarantees a consistently good printed image and plays a major part in preventing premature wear of the printhead.

Otherwise, the maintenance is limited to monthly cleaning of the device.



Attention!

The printer can be damaged by aggressive cleaners.

Do not use abrasive cleaners or solvents for cleaning the external surfaces or modules.

Recommended cleaners	
Print rollers	Cleaner for rollers W1 (Part No. Y133251)
Printing line and label sensor	Isopropanol > 99,9%
Other surfaces	Isopropanol 70-100%

Table 5 Recommended cleaners

- ▶ Remove dust and paper fluff from the print area with a soft brush or vacuum cleaner.

6.2 Cleaning the Print Rollers

Accumulations of dirt on the print rollers may impair the media transport and the print quality.

- ▶ Lift the printheads.
- ▶ Remove media and transfer ribbon from the printer.
- ▶ Remove deposits with roller cleaner and a soft cloth.
- ▶ If the roller appears damaged, send for service.

6.3 Cleaning the Printheads

Cleaning intervals: direct thermal printing - every media roll change
 thermal transfer printing - every ribbon roll change

Substances may accumulate on the printheads during printing and adversely affect printing, e.g. differences in contrast or vertical stripes.



Attention!

Printheads can be damaged!

Do not use sharp or hard objects to clean the printheads.

Do not touch protective glass layer of the printheads.



Attention!

Risk of injury from the hot printhead lines.

Ensure that the printheads have cooled down before starting cleaning.

- ▶ Lift the printheads.
- ▶ Remove media and transfer ribbon from the printer.
- ▶ Clean printhead surfaces with a cotton swab or a soft cloth dipped in Isopropanol > 99,9%.
- ▶ Allow printheads to dry for 2–3 minutes before commissioning the printer.

6.4 Cleaning the Label Sensor



Attention!

Label sensor can be damaged!

Do not use sharp or hard objects or solvents to clean the label sensor.

The label sensor can become dirtied by paper dust. This can adversely affect label detection.

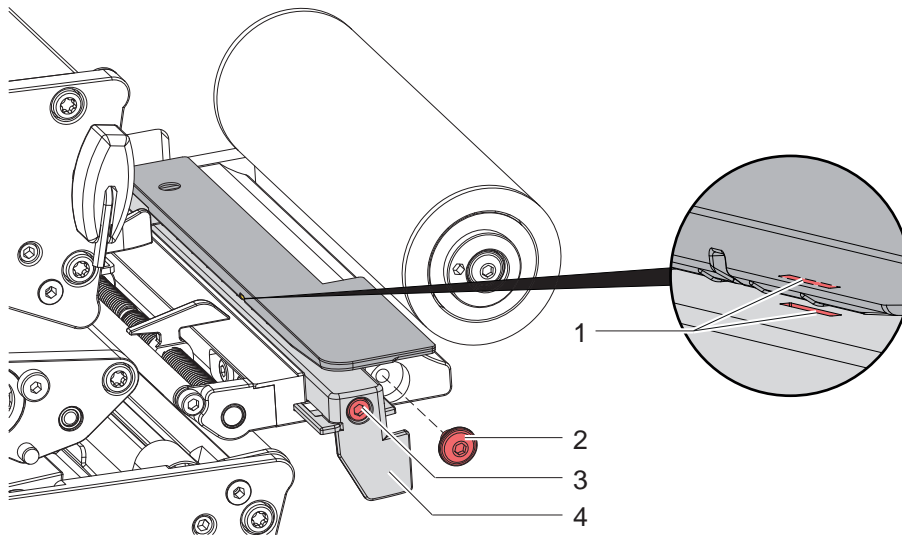

Figure 21 Cleaning the label sensor

1. Remove labels and transfer ribbon from the printer.
2. Remove screw (2).
3. Loosen screw (3)
4. Slowly pull label sensor outward via the tab (4). Ensure that the label sensor cable is not tensioned by this.
5. Clean label sensor the slots (1) with a soft cloth dipped in Isopropanol > 99,9%.
6. Push label sensor back via tab (4) and set it (▷ 4.1.3 on page 14).
7. Insert screw (2).
8. Reload labels and transfer ribbon.

7.1 Error Display

The appearance of an error will be shown on the display:



Figure 22 Error display

The error treatment is pending on the error type ▷ 7.2 on page 23.

The display offers the following possibilities to continue after an error occurred:

<i>Repeat</i>	The print job will be continued after clearing the error cause.
<i>Cancel</i>	The print job will be cancelled.
<i>Feed</i>	The paper feed will be synchronized. Following the print job can be continued.
<i>Ignore</i>	The error message will be ignored. The print job will be continued possibly with limited performance.
<i>Save log</i>	The error does not allow print operation. For detailed analysis several system files can be saved on an external memory.

Table 6 Button in the error display



Attention!

The labels, which are printed by the lower printer but not yet printed by the upper printhead when the error occurs, cannot be repeated by the printer. So the amount of the printed label will be reduced within the print job.

- ▶ If necessary print more labels in a new job.

If the print job contains counters, after pressing *Repeat* the print job would be resumed with erroneous counter values.

- ▶ Quit the print job with *Cancel*.
- ▶ Start a new print job with adapted counter values.

7.2 Error Messages and Fault Correction

Error message	Cause	Remedy
<i>Barcode error</i>	Invalid barcode content, e.g. alphanumeric characters in a numerical barcode	Correct the barcode content.
<i>Barcode too big</i>	The barcode is too big for the allocated area of the label	Reduce the size of the barcode or move it.
<i>Check ribbon ink side (lower/upper printhead)</i>	Identified ribbon unwinding direction does not match to the setup setting	Ribbon loaded incorrectly. Clean the printhead ▷ 6.3 on page 20. Load the ribbon correctly.
		Setting does not match to the used ribbon. Correct the setting.
<i>Cutter blocked</i>	Cutter cannot return into its home position and stays in an undefined position	Switch off the printer. Remove material. Switch on the printer. Restart print job. Change material
	No cutter function	Switch the printer off and then on. If error recurs contact Technical Support.
<i>Cutter jammed</i>	The cutter is unable to cut the labels but is able to return into its home position	Press <i>Cancel</i> Change material.
<i>Device not conn.</i>	Programming addresses a non-existent device	Either connect this device or correct the programming.
<i>File not found</i>	Requested file is not on the card	Check the contents of the card.
<i>Font not found</i>	Error with the selected download font	Cancel current print job, change font.
<i>Lower printhead disabled and closed</i>	The lower printhead is closed although the parameter <i>Disable lower head</i> is activated	For single side printing open the lower printhead. For double side printing deactivate the parameter <i>Disable lower head</i> .
<i>Lower/upper printhead open</i>	Printhead not locked	Lock printhead.
<i>Lower/upper printhead out of ribbon</i>	Out of transfer ribbon	Insert new transfer ribbon.
	Transfer ribbon melted during printing	Cancel current print job. Change the heat level via software. Clean the printhead ▷ 6.3 on page 20 Load transfer ribbon. Restart print job.
	The printer is loaded with thermal labels, but the software is set to transfer printing	Cancel current print job. Set software to direct thermal printing. Restart print job.
<i>Lower/upper printhead too hot</i>	Printhead is overheated	After pausing the print job will be continued automatically. If the fault recurs repeatedly, reduce the heat level or the print speed via software.
<i>Memory overflow</i>	Current print job contains too much information, e.g. selected font, large graphics	Cancel current print job. Reduce amount of data to be printed.
<i>Moving head failed</i>	Error of the ribbon saver, end position for lifting or lowering the printhead not reached	Switch the printer off and then on. If error recurs contact Technical Support.
<i>Name exists</i>	Duplicate usage of field name in the direct programming	Correct programming
<i>No label found</i>	There are labels missing on the label material	Press <i>Repeat</i> repeatedly until printer recognizes the next label on the material.
	The label format as set in the software does not correspond with the real label format	Cancel current print job. Change the label format set in the software. Restart print job.
	Printer is loaded with continuous paper, but the software is set on labels	Cancel current print job. Change the label format set in the software. Restart the print job.
<i>No label size</i>	The size of the label is not defined in the programming.	Check programming.

Error message	Cause	Remedy
<i>Out of paper</i>	Out of label roll	Load labels.
	Error in the paper feed	Check paper feed.
<i>Pinch roller open</i>	The pressing roller system is not locked.	Lock the pressing roller system.
<i>Read error</i>	Read error when reading from the memory card	Check data of the card. Backup data, reformat card.
<i>Remove lower/ upper ribbon</i>	Transfer ribbon is loaded although the printer is set to direct thermal printing	for direct thermal printing remove ribbon
		for thermal transfer printing set the printer in the configuration or in the software to transfer printing
<i>Syntax error</i>	Printer has received an unknown or invalid command from the computer.	Press <i>Ignore</i> to skip the command or press <i>Cancel</i> to cancel the print job.
<i>Unknown card</i>	Card not formatted, Type of card not supported	Format card, use different type of card.
<i>Voltage error</i>	Hardware error	Switch the printer off and then on. If error recurs contact Technical Support. It is shown which voltage has failed. Please note.
<i>Write error</i>	Hardware error	Repeat the write process, reformat card.

Table 7 Error Messages and Fault Correction

7.3 Problem Solution

Problem	Cause	Remedy
Transfer ribbon creases	Transfer ribbon deflection not adjusted	Adjust the transfer ribbon deflection. ▷ 4.3 on page 16
	Head locking system not adjusted	Adjust the head locking system. ▷ 4.1.4 on page 14
	Transfer ribbon too wide	Use a transfer ribbon slightly wider than the width of label.
Print image has smears or voids	Printhead is dirty	Clean the printhead ▷ 6.3 on page 20
	Temperature too high	Decrease temperature via software.
	Unsuitable combination of labels and transfer ribbon	Use different type of ribbon.
Printer does not stop after transfer ribbon runs out	Thermal printing is chosen in the software	Change to thermal transfer printing.
Printer prints a sequence of characters instead of the label format	Printer is in ASCII dump mode	Cancel the ASCII dump mode.
Printer transports label media, but transfer ribbon does not move	Transfer ribbon incorrectly inserted.	Check and, if necessary, correct the transfer ribbon web and the orientation of the label side.
	Unsuitable combination of labels and transfer ribbon	Use different type of ribbon.
Vertical white lines in the print image	Printhead is dirty	Clean the printhead. ▷ 6.3 on page 20
	Printhead is defective (failure of heat elements)	Contact Technical Support
Horizontal white lines in the print image	Printer is used with the <i>backfeed > smart</i> in the cut or peel-off mode	Set the <i>backfeed > always</i> in the setup. ▷ Configuration Manual.
Print image is irregular, one side is lighter	Printhead is dirty	Clean the printhead. ▷ 6.3 on page 20
	Head locking system not adjusted	Adjust the head locking system. ▷ 4.1.4 on page 14

Table 8 Problem solution

8.1 Media Dimensions

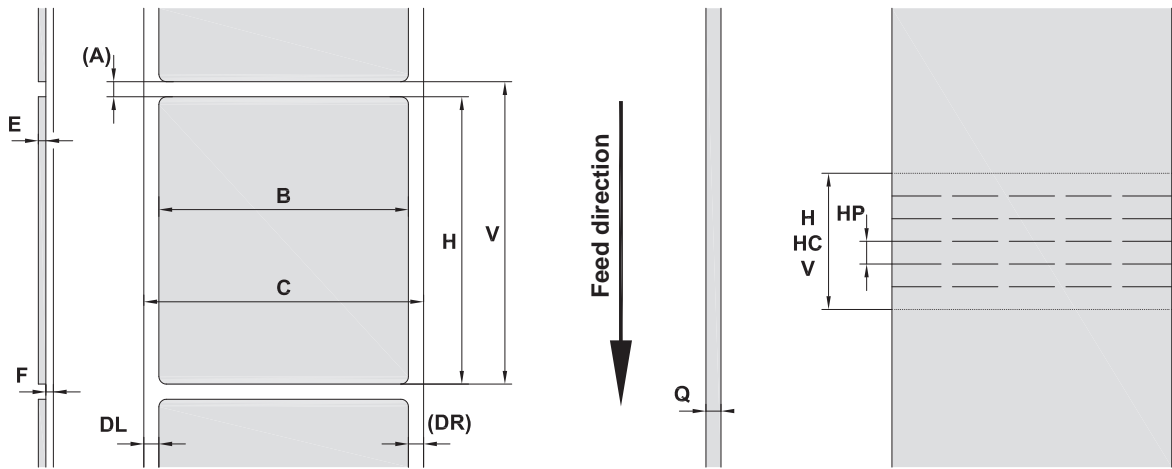

Figure 23 Media dimensions

Dim.	Designation	Dim. in mm
B	Label width	10 - 110
A	Label distance	> 2
C	Media width	
	Liner, continuous media	4 - 114
	Shrink tube, ready for use	≤ 114
	Shrink tube, continuous, pressed	4 - 85
DL	Left margin	≥ 0
DR	Right margin	≥ 0
E	Label thickness	0,05 - 0,6
F	Liner thickness	0,05 - 0,16
Q	Media thickness	
	Continuous media	0,05 - 0,5
	Shrink tube	≤ 1,1
-	Height of media passage	2
H	Label height, print zone height	≥ 20
V	Feed length	≥ 20
HC	Cut length	≥ 10
HP	Perforation length	≥ 3
	<ul style="list-style-type: none"> • Small label sizes, thin materials or strong glue can lead to limitations. Critical applications need to be tested and cleared. • Note the bending stiffness ! Material must be flexible to follow the radius of the print roller ! 	

Table 9 Media dimensions

8.2 Device Dimensions

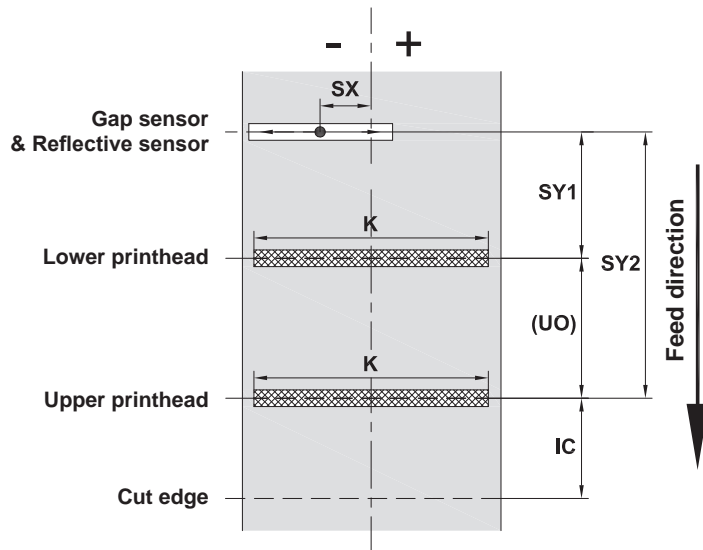

Figure 24 Device dimensions

Dim.	Designation	Dim. in mm
IC	Distance printhead - cut edge	48,6
K	Print width	105,7
SX	Distance gap/reflective sensor - middle of paper track i.e. permissible distance of reflex or cut-out marks from the middle of the material	-55 - ±0
SY1	Distance gap/reflective sensor - lower printhead	87,4
SY2	Distance gap/reflective sensor - upper printhead	148,3
UO	Distance lower printhead - upper printhead	60,9

Table 10 Device dimensions

8.3 Reflex Mark Dimensions

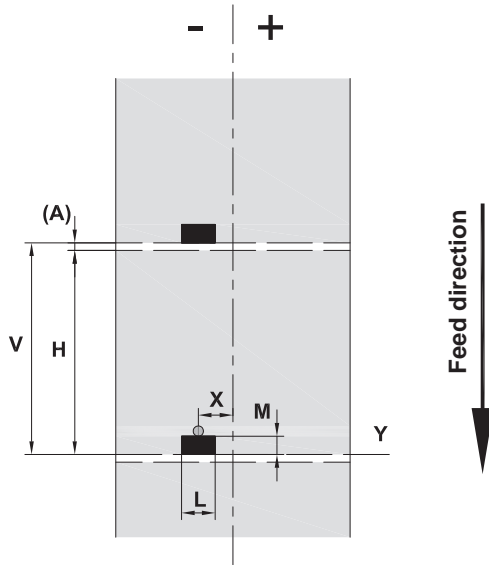

Figure 25 Reflex mark dimensions

Dim.	Designation	Dim. in mm
H	Print zone height	≥ 20
A	Print zone distance	> 2
V	Feed length	> 7
L	Width of reflex mark	> 5
M	Height of reflex mark	3 - 10
X	Distance mark - middle of media track = Distance gap/reflective sensor - middle of media track	-55 - ±0
Y	Sensor recognized virtual print zone front edge	Front edge of mark
	<ul style="list-style-type: none"> • Reflex marks must be on the back side of the material (liner). • Material sensor for reflex marks on the top side on request. • Specification is valid for black marks. • Recognition of colored marks may fail. ► Preliminary tests are needed. 	

Table 11 Reflex mark dimensions

8.4 Cut-out Mark Dimensions

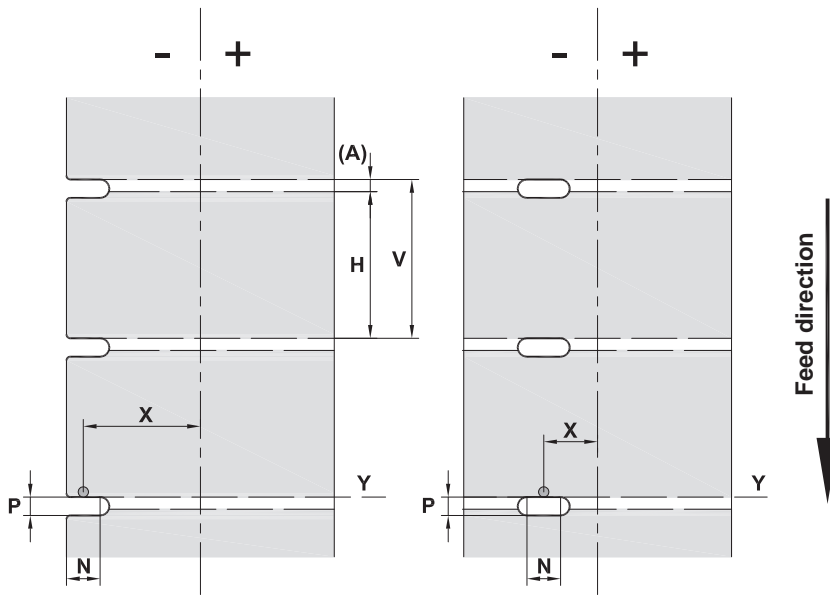

Figure 26 Cut-out mark dimensions

Dim.	Designation	Dim. in mm
H	Print zone height	≥ 20
A	Print zone distance	> 2
V	Feed length	> 7
N	Width of cut-out	> 5
P	Height of cut-out	2 - 10
X	Distance cut-out - middle of media track = Distance gap/reflective sensor - middle of media track	-55 - ±0
Y	Sensor recognized virtual print zone front edge with gap sensor recognition	Rear edge cut-out

Table 12 Cut-out mark dimensions

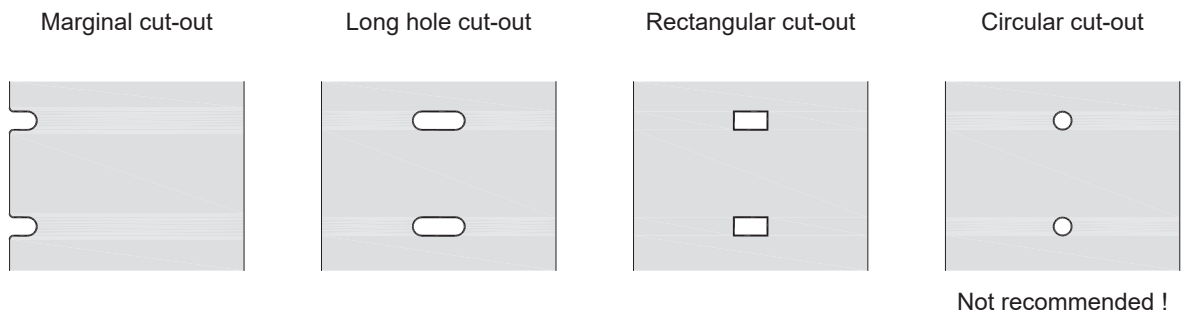

Figure 27 Samples for cut-out marks

9.1 Agency Compliance and Approvals

United States

FCC Notice

This equipment has been tested and found to comply with the limits for a Class A digital device, pursuant to part 15 of the FCC Rules. These limits are designed to provide reasonable protection against harmful interference when the equipment is operated in a commercial environment. This equipment generates, uses, and can radiate radio frequency energy and, if not installed and used in accordance with the instruction manual, may cause harmful interference to radio communications.

Operation of this equipment in a residential area is likely to cause harmful interference in which case the user will be required to correct the interference at his own expense.

Changes or modifications not expressly approved by the party responsible for compliance could void the user's authority to operate the equipment.

This device complies with Part 15 of the FCC Rules. Operation is subject to the following two conditions: (1) This device may not cause harmful interference and, (2) this device must accept any interference received, including interference that may cause undesired operation.

Canada

Innovation, Science and Economic Development (ISED)

Canada ICES-003:

CAN ICES-3 (A)/NMB-3(A)

Mexico

IFT notice: La operación de este equipo está sujeta a las siguientes dos condiciones: (1) es posible que este equipo o dispositivo no cause interferencia perjudicial y (2) este equipo o dispositivo debe aceptar cualquier interferencia, incluyendo la que pueda causar su operación no deseada.

Europe



Warning!

This is a class A product. In a domestic environment this product may cause radio interference in which case the user may be required to take adequate measures.



Waste Electrical and Electronic Equipment Directive

In accordance with the European WEEE Directive, this device needs to be recycled in accordance with local regulations.

RoHS Directive 2011/65/EU, 2015/863/EU

This product is CE marked and complies with the European Union's Directive 2011/65/EU OF THE EUROPEAN PARLIAMENT AND OF THE COUNCIL of 8 June 2011 on the restriction of the use of certain hazardous substances in electrical and electronic equipment.

EU Directive 2015/863 of 31 March 2015 (RoHS 3) amends Annex II to Directive 2011/65/EU of the European Parliament and of the Council as regards the list of restricted substances.

Batteries Directive 2006/66/EC



This product contains a lithium coin cell battery. The crossed-out wheeled bin shown to the left is used to indicate 'separate collection' for all batteries and accumulators in accordance with European Directive 2006/66/EC. Users of batteries must not dispose of batteries as unsorted municipal waste. This Directive determines the framework for the return and recycling of used batteries and accumulators that are to be collected separately and recycled at end of life. Please dispose of the battery according to your local regulations.

Notice to Recyclers

To remove the lithium coin cell battery:

1. Disassemble printer and locate the lithium coin cell battery located on the main circuit board.
2. Using a small screwdriver, pry the battery from its holder and remove the battery from the board.
Dispose of in accordance with local regulations.

China

China RoHS Hazardous Substance Table related to this product is available at www.bradyid.com/BBP72Pluscompliance.

警告

此为A级产品。在生活环境中，该产品可能会造成无线电干扰。在这种情况下，可能需要用户对干扰采取切实可行的措施。

仅适用于非热带气候条件下安全使用

Taiwan**Class A Statement**

警告:為避免電磁干擾，本產品不應安裝或使用於住宅環境

Taiwan Restricted Substances Containment Status (RoHS Declaration) related to this product is available at www.BradyID.com/BBP72Pluscompliance.

Importer:

香港商貝迪香港有限公司

臺北市中山區南京東路3段101號4樓

BRADY CORPORATION HONG KONG LIMITED

4th Floor, No. 101, Section 3, Nanjing East Road, Zhongshan District, Taipei City

Turkey

Turkish Ministry of Environment and Forestry

(Directive on the Restriction of the use of certain hazardous substances in electrical and electronic equipment).

Türkiye Cumhuriyeti: EEE Yönetmeliğine Uygundur

C

Cleaning
 label sensor21
 printhead.....20
 print roller.....20
 Cleaning information.....20
 Connecting8
 Contents of delivery.....8
 Cut-out marks29
 Cutting19

D

Designing print image.....17
 Device dimensions27
 Device overview6
 Display.....9

E

Environment5
 Errors
 correction23
 messages23

H

Head locking systems
 setting14

I

Identical images.....17
 Important information.....4
 Intended use.....4

L

Label sensor
 cleaning21
 setting13
 Lithium battery.....5
 Loading transfer ribbon.....15
 Loss of data19
 Loss of material18

P

Pause on media low19
 Perforating19
 Power supply5
 Printhead
 cleaning20
 damage.....17
 Print roller, cleaning.....20
 Problem solution.....25

R

Reflex marks.....28
 Ribbon deflection, setting16
 Ribbon feed path, setting.....16
 RS232 interface.....18

S

Safety instructions5
 Service work.....5
 Setting-up8
 Supply voltage8
 Switching on8

U

Unpacking.....8
 USB device interface.....7

V

Voltage.....5

W

Warning stickers5