



 **BRADY**

# i5300

**Serious versatility.  
Powerful simplicity.**

**INDUSTRIAL LABEL PRINTER**

# Precision printing **MADE SIMPLE**

Zero setup. Zero adjustments. Zero wasted labels.

More efficiency. Less effort. Welcome to a faster, easier and better overall labeling experience — powered by Brady Print Technology. From auto setup and intuitive operation features to rock-solid printing performance paired with world-class Brady materials, get the job done right with the i5300.



## **No wasted labels**

Maximize material use and cut costs. Print on the very first label.



## **20-second setup**

Change materials in just 20 seconds with drop-lock-print technology.



## **Pinpoint precision**

Get better print placement and greater small-font sharpness.

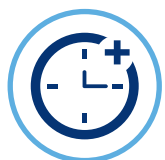

## **Everyday operation**

Save time with faster printing. Pause and resume jobs easily.



# BETTER STARTS WITH BRADY

The performance you need. From the name you trust.

## KEY FEATURES



### No wasted labels

- ▶ Prints on the first label
- ▶ No calibration required
- ▶ No trial and error in setup

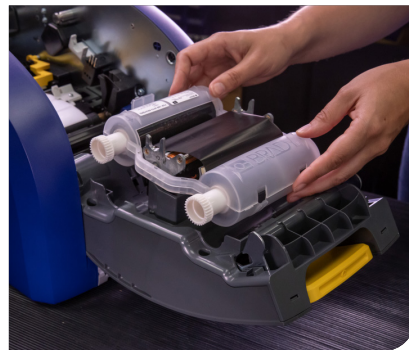

### 20-second changeovers

- ▶ No sensor adjustments
- ▶ No heat or speed adjustments
- ▶ Drop-lock-print technology

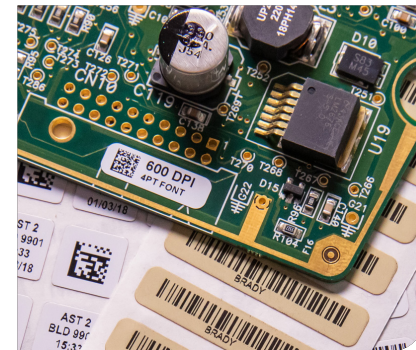

### 300 and 600 dpi models

- ▶ Offers greater precision
- ▶ Prints smaller fonts clearly
- ▶ Prints labels as small as 0.20"



### 1-click label setup

- ▶ Recognizes materials in seconds
- ▶ Software, printer, materials "talk"
- ▶ Time-saving smart technology



### Faster print speeds

- ▶ Ideal for any size job or high mix
- ▶ Better print performance
- ▶ Offers high-volume efficiency



### Rugged construction

- ▶ Features a metal frame
- ▶ Reliable internal print engine
- ▶ Excellent heat management

Work with the speed and precision your work demands.

i5300 Industrial Label Printer

# Premium performance

## INDUSTRIAL DURABILITY

Manage high-volume and high-mix printing easily with the i5300. Built for rugged industrial use, it has many built-in features like an auto cutter, a large color touchscreen and multiple ports to transfer data.



### Double-side wire sleeve printing

External feed slot and print app enable 2-pass printing for double-side heat-shrink sleeves.

### Rugged design

Solid construction with metal framing and gearing for higher throughput and workhorse durability.

### Roller replacement door hatch

Provides immediate access to the print roller for inspection or replacement.

### Big 7" color touchscreen

Large icons are user-friendly and allow for faster navigation.

### Print queue

Print immediately, store or customize the order in which jobs print.

### Intuitive interface

Communicates installed part numbers, remaining supply, status, in-job navigation and label preview.

### Connectivity and ports

3 USB ports and Ethernet with optional Wi-Fi / Bluetooth.

# Serious production

## SMOOTHER OPERATION

Load materials and print in just seconds with the incredibly simple, yet powerful i5300. There's no set up, no adjustments and no waste. Move through work faster with media guides, integrated sensors and materials with Brady Print Technology.



### 0.20" to 4" label widths

Prints small labels for electronics and laboratories, as well as larger labels up to 4" wide.

### Easy loading with 20-second changeovers

Labels and ribbons drop in with no thread-through, sensor adjustment, calibration or wasted labels.

### Built-in auto cutter

Cuts off material after a job, after a label or not at all.

### Fast print speed

Auto-set at 1 to 10 inches per second (depending on material) with user override for faster or slower printing.

### Field-replaceable printhead

Tool-less printhead replacement using a single-release pin and connectors (replace with same dpi printhead only).

### Field-replaceable print roller

Easily replace a damaged or worn roller to ensure optimal print quality.

### Smart media rolls

All rolls have Brady Print Technology that adjust for speed, size, heat, layout and approved ribbon/material pairings to eliminate trial and error, calibration and wasted materials.

### Media guides and integrated sensors

Sensors automatically align when guides squeeze together. There's no adjustments or alignment trial and error.

# THE RIGHT TECHNOLOGY

from the right partner

## i5300 with Brady Print Technology

Elevate your performance with i5300. It's got Brady Print Technology — an advanced system that enables the printer, ribbon and materials to “talk” to each other. The result: easy-to-use features like auto setup, auto part recognition and auto adjustments that save you time and money.



### Fast setup. No waste.

Set up your i5300 in just seconds. Because the printer recognizes smart-cell chips in label rolls and ribbons, you save steps. And there's zero waste since you print on the very first label.



### Simple printing

Get more work done with easy i5300 operation. Auto features and an intuitive interface work together, saving you precious time on any industrial application.

# Industrial Printing MADE SIMPLE

No setup. No complications. No waste. No kidding.



## i5300 Models and Software Options

The i5300 offers a number of time- and cost-saving benefits:

- ▶ Quickly change over materials in under 20 seconds
- ▶ Print on the first label – no calibration required
- ▶ Rugged construction for higher volumes and larger jobs
- ▶ Precise printing on labels down to 0.20 inches
- ▶ Labels for almost any application



Maximize your i5300 printing experience using Brady Workstation label creation software. With driverless operation, it integrates easily with existing systems and platforms.

Learn more on page 71.

Printer ships with Brady Workstation label creation software, power and USB cords, cleaning kit, Quick Start Guide and USB user manual, Windows driver and how-to videos.

Catalog #	
151290	BradyPrinter i5300, 300 dpi, Wi-Fi, Brady Workstation PWID Software Suite
151291	BradyPrinter i5300, 300 dpi, Wi-Fi, Brady Workstation Lab ID Software Suite
151292	BradyPrinter i5300, 300 dpi, Wi-Fi, Brady Workstation SFID Software Suite
151293	BradyPrinter i5300, 300 dpi, Wi-Fi, Brady Workstation GHS Labels Software
151294	BradyPrinter i5300, 600 dpi, Wi-Fi, Brady Workstation PWID Software Suite
151295	BradyPrinter i5300, 600 dpi, Wi-Fi, Brady Workstation Lab ID Software Suite
153710	BradyPrinter i5300, 600 dpi, Wi-Fi, Brady Workstation SFID Software Suite
153711	BradyPrinter i5300, 600 dpi, Wi-Fi, Brady Workstation GHS Labels Software

The above part number descriptions do not reflect complete product data — refer to the specification sheet for complete details. **i5300 printers accept all B30 / B33 series version V2 media.**



## Simple and intuitive

Zero waste. 20-second changeovers.

### i3300 Industrial Label Printer

Zero calibration, zero wasted labels. A no-fuss, mid-volume industrial printer. Uses time-saving smart technology for faster setup. Just drop in ribbons and label rolls. There are no manual adjustments. Print on a wide range of materials and auto-cut labels as small as 0.25 inches.

(300 dpi)

# PRINT RIBBONS

Get the right ribbon for every print job with the i5300's Brady Print Technology. Qualified, pre-tested ribbons eliminate heat, speed and size adjustments. There's no trial and error, and there are no wasted labels.

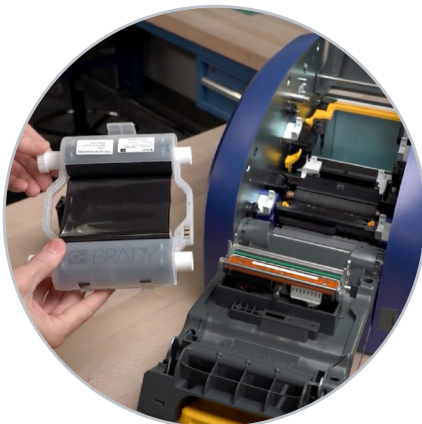

## Rapid ribbon changes

Get 5-second ribbon supply changes with "Drop and Click" technology. No calibrating, no threading and no waste. Each tough, smear-proof ribbon withstands years of industrial use.

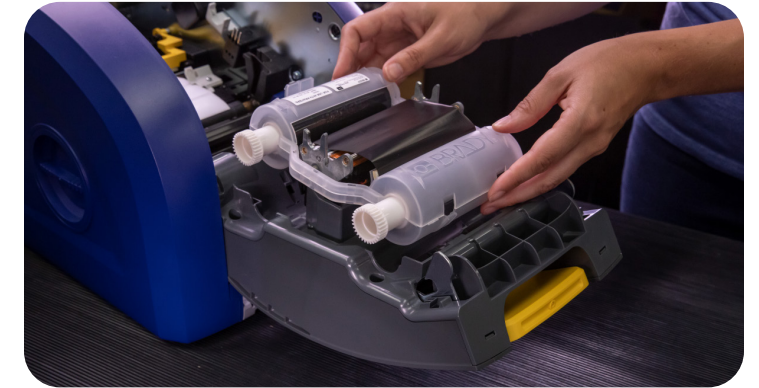

## 5-second ribbon installation

- ▶ Tough, smear-proof ribbons produce long-lasting printed text and can withstand years in industrial areas and outdoor conditions
- ▶ Self-contained cartridges drop straight into printer with a "click"
- ▶ No calibrating, no threading, no wasted feeding, no hassles and the ink will always be facing the right direction!
- ▶ Printer notifies user if installed ribbon is not recommended for installed labels

## Single-Color Print Ribbons

Catalog #	Color	Size Inch (mm)	Length Feet (m)
B30-R10000	Black	4.330 (109.9)	200 ft. (60.9 m)
B30-R4300	Black	4.330 (109.9)	200 ft. (60.9 m)
B30-R4900	Black	4.330 (109.9)	200 ft. (60.9 m)
B30-R6000	Black	4.330 (109.9)	200 ft. (60.9 m)
B30-R6200	Black	4.330 (109.9)	200 ft. (60.9 m)
B30-R6300	Black	4.330 (109.9)	200 ft. (60.9 m)
B30-R6400	Black	4.330 (109.9)	200 ft. (60.9 m)
B30-R6600	Black	4.330 (109.9)	200 ft. (60.9 m)
B30-R10000-WT	White	4.330 (109.9)	200 ft. (60.9 m)
B30-R4400-WT	White	4.330 (109.9)	200 ft. (60.9 m)
B30-R6700-WT	White*	4.330 (109.9)	200 ft. (60.9 m)
B30-R6800-WT	White***	4.330 (109.9)	200 ft. (60.9 m)
B30-R4500-SV	Silver*	4.330 (109.9)	200 ft. (60.9 m)
B30-R10000-RD	Red****	4.330 (109.9)	200 ft. (60.9 m)
B30-R10000-GN	Green****	4.330 (109.9)	200 ft. (60.9 m)
B30-R10000-BL	Blue****	4.330 (109.9)	200 ft. (60.9 m)
B30-R10000-YL	Yellow** / ****	4.330 (109.9)	200 ft. (60.9 m)
B30-R10000-YL2	Yellow** / ****	4.330 (109.9)	200 ft. (60.9 m)
B30-R10000-OR	Orange****	4.330 (109.9)	200 ft. (60.9 m)
B30-R10000-MA	Magenta****	4.330 (109.9)	200 ft. (60.9 m)

\* B30-R4500-SV ribbon for use with B-342 black and B-345 black sleeves only; B30-R6700-WT ribbon for use with B-345 black sleeves only.

\*\* B30-R10000-YL for printing yellow onto white. B30-R10000-YL2 for printing yellow onto other colors of B-595.

\*\*\* B30-R6800-WT for use with B-8117 black labels only.

\*\*\*\* Colored ribbons optimized for use on white material. Test use on other material colors for suitability to your application.



# Print Ribbon & Label Material Compatibility

To ensure the best legend permanence, all ribbons have been developed to meet the requirements of the materials to be printed on. Use the guide below to determine which ribbon series is recommended with your print materials.



●	Recommended ribbon for use with respective material.
▲	Acceptable ribbon for use with respective material.
UL	Materials are UL recognized with its respective ribbon.
CSA	Materials are CSA approved with its respective ribbon.

B-# material		B30-R4300	B30-R4900	B30-R6000	B30-R6200	B30-R6300	B30-R6400	B30-R6600	B30-R10000	B30-R4500-SV*	B30-R4400-WT	B30-R6700-WT*	B30-R6800-WT***	B30-R10000-WT	B30-R10000-YL**	B30-R10000-YL2**	B30-R10000-****	
B-342	Polyolefin	●	-	-	-	-	-	●	-	-	-	-	-	-	-	-	-	-
B-342 BLK	Polyolefin	-	-	-	-	-	-	-	●	-	-	-	-	-	-	-	-	-
B-344	Polyolefin	-	-	-	-	-	-	●	-	-	-	-	-	-	-	-	-	-
B-344 YEL	Polyolefin	●	-	-	-	-	-	●	-	-	-	-	-	-	-	-	-	-
B-344 BLK	Polyolefin	-	-	-	-	-	-	-	-	-	●	-	-	-	-	-	-	-
B-345	Polyolefin	-	-	▲	-	-	-	●	-	-	-	-	-	-	-	-	-	-
B-345 BLK	Polyolefin	-	-	-	-	-	-	-	●	●	-	-	-	-	-	-	-	-
B-403	Paper	●	-	-	-	-	-	-	-	-	-	-	-	-	-	-	-	-
B-413	Polyester	-	-	● UL	-	-	-	-	-	-	-	-	-	-	-	-	-	-
B-414	Printable VELCRO® Hook	-	-	●	●	-	-	-	-	-	-	-	-	-	-	-	-	-
B-417	Vinyl	● UL	-	-	-	-	-	-	-	-	-	-	-	-	-	-	-	-
B-422	Polyester	-	-	● UL / CSA	●	-	-	-	-	-	-	-	-	-	-	-	-	-
B-423	Polyester	-	-	● UL / CSA	▲	-	-	-	-	-	-	-	-	-	-	-	-	-
B-424	Paper	●	-	-	-	-	-	-	-	-	-	-	-	-	-	-	-	-
B-425	Polypropylene	● UL / CSA	-	-	-	-	● UL / CSA	-	-	-	-	-	-	-	-	-	-	-
B-427	Vinyl	● UL	-	-	-	-	-	-	-	-	-	-	-	-	-	-	-	-
B-428	Metallized Polyester	● UL / CSA	-	-	-	-	-	-	-	-	-	-	-	-	-	-	-	-
B-430	Polyester	-	-	● UL / CSA	-	-	-	-	-	-	-	-	-	-	-	-	-	-
B-432	Clear Polyester	-	▲ UL	● UL / CSA	-	-	-	-	-	-	-	-	-	-	-	-	-	-
B-434A	Metallized Polyester	-	-	● UL / CSA	-	-	-	-	-	-	-	-	-	-	-	-	-	-
B-435	Metallized Polyester	-	-	● UL / CSA	-	-	-	-	-	-	-	-	-	-	-	-	-	-
B-437	Polyvinylfluoride	●	-	-	●	-	-	-	-	-	-	-	-	-	-	-	-	-
B-437 YEL	Polyvinylfluoride	●	-	-	●	-	-	-	-	-	-	-	-	-	-	-	-	-
B-438	Metallized Polyester	● UL / CSA	-	-	-	-	-	-	-	-	-	-	-	-	-	-	-	-
B-439	Vinyl	-	-	●	-	-	-	-	-	-	-	-	-	-	-	-	-	-
B-443	Polyester	-	-	-	-	-	● UL / CSA	-	-	-	-	-	-	-	-	-	-	-
B-461	Polyester	●	-	-	▲	-	-	-	-	-	-	-	-	-	-	-	-	-
B-472	Polyimide	●	-	-	●	-	-	-	-	-	-	-	-	-	-	-	-	-
B-473	Polyester	-	-	● UL / CSA	-	-	-	-	-	-	-	-	-	-	-	-	-	-
B-481	Polyester	-	-	-	-	-	●	-	-	-	-	-	-	-	-	-	-	-
B-483	Polyester	-	-	● UL / CSA	-	-	-	-	-	-	-	-	-	-	-	-	-	-
B-483A	ToughStripe® Polyester	-	-	●	-	-	-	-	-	-	●	-	-	-	-	-	-	-
B-484A	Polyester	-	-	● UL	-	-	-	-	-	-	-	-	-	-	-	-	-	-
B-486B	Metallized Polyester	● UL / CSA	-	-	-	-	-	-	-	-	-	-	-	-	-	-	-	-

For further material compatibility related to UL/CSA, see pages 18-22 or refer to Brady Tech Data Sheet for complete material performance specifications

# Print Ribbon & Label Material Compatibility

(Continued)

●	Recommended ribbon for use with respective material.
▲	Acceptable ribbon for use with respective material.
UL	Materials are UL recognized with its respective ribbon.
CSA	Materials are CSA approved with its respective ribbon.

B-# material		B30-R4300	B30-R4900	B30-R6000	B30-R6200	B30-R6300	B30-R6400	B30-R6600	B30-R10000	B30-R4500-SV*	B30-R4400-WT	B30-R6700-WT*	B30-R6800-WT***	B30-R10000-WT	B30-R10000-YL**	B30-R10000-YL2**	B30-R10000-****	
B-489A	Polyester	● UL / CSA	-	-	-	-	-	-	-	-	-	-	-	-	-	-	-	-
B-490	Polyester	●	-	-	-	-	-	-	-	-	-	-	-	-	-	-	-	-
B-492	Polyester	-	-	-	-	-	●	-	-	-	-	-	-	-	-	-	-	-
B-494	Polyester	-	-	-	-	-	●	-	-	-	-	-	-	-	-	-	-	-
B-498	Repositionable Cloth	▲ UL	-	-	● UL	-	-	-	-	-	-	-	-	-	-	-	-	-
B-499	Nylon Cloth	▲ UL / CSA	-	● UL	-	-	-	-	-	-	-	-	-	-	-	-	-	-
B-509	Printable Magnetic	-	-	●	-	-	-	-	●	-	-	-	-	-	-	-	-	●
B-526	Photoluminescent Polyester	-	-	●	-	-	-	-	●	-	-	-	-	-	-	-	-	●
B-549	Polyester	-	-	●	-	-	-	-	●	-	-	-	-	-	-	-	-	●
B-569	Polyester	-	-	●	-	-	-	-	●	-	-	-	-	-	-	-	-	●
B-581	Repositionable Vinyl	-	-	●	-	-	-	-	●	-	-	-	-	-	-	-	-	●
B-584	Reflective	-	-	●	-	-	-	-	●	-	-	-	-	-	-	-	-	●
B-593	Polyester	-	-	●	-	-	-	-	-	-	●	-	-	-	-	-	-	-
B-595	Outdoor Vinyl	-	-	●	-	-	-	-	●	-	-	-	-	●	-	●	●	-
B-618	Polyester	-	● UL	● UL	-	-	-	-	-	-	-	-	-	-	-	-	-	-
B-717	Polyimide	-	-	● UL	-	-	-	-	-	-	-	-	-	-	-	-	-	-
B-718	Polyimide	-	-	● UL	-	-	-	-	-	-	-	-	-	-	-	-	-	-
B-719	Polyimide	-	-	● UL	-	-	-	-	-	-	-	-	-	-	-	-	-	-
B-724	Polyimide	●	-	-	-	-	-	-	-	-	-	-	-	-	-	-	-	-
B-727	Polyimide	-	-	● UL	-	-	-	-	-	-	-	-	-	-	-	-	-	-
B-728	Polyimide	-	-	● UL	-	-	-	-	-	-	-	-	-	-	-	-	-	-
B-729	Polyimide	-	-	● UL	-	-	-	-	-	-	-	-	-	-	-	-	-	-
B-777	Polyimide	-	-	-	-	● UL / CSA	-	-	-	-	-	-	-	-	-	-	-	-
B-851	Non-Adhesive Tag	-	-	●	-	-	-	-	●	-	-	-	-	-	-	-	-	●
B-854	ToughWash® Metal Detectable	-	-	●	-	-	-	-	-	-	-	-	-	-	-	-	-	-
B-855	ToughWash	-	-	●	-	-	-	-	-	-	-	-	-	-	-	-	-	-
B-7425	Polypropylene	▲	-	-	-	-	●	-	-	-	-	-	-	-	-	-	-	-
B-7425-AC	Polypropylene	▲	-	-	-	-	●	-	-	-	-	-	-	-	-	-	-	-
B-7569	Vinyl Film	-	-	●	-	-	-	-	●	-	-	-	-	-	-	-	-	-
B-7641	Polyolefin	-	-	●	-	-	-	●	-	-	-	-	-	-	-	-	-	-
B-7642	Polyolefin	●	-	-	-	-	●	-	-	-	-	-	-	-	-	-	-	-
B-7643	Polyurethane	-	-	●	-	-	-	-	-	-	-	-	-	-	-	-	-	-
B-8117	Black Polyester	-	-	-	-	-	-	-	-	-	-	▲ UL	-	● UL	-	-	-	-
B-8591	Outdoor Polyester	-	-	● UL	-	-	-	-	-	-	-	-	-	-	-	-	-	-
B-8591 SLV	Outdoor Polyester	-	-	-	-	-	-	● UL	-	-	-	●	-	-	-	-	-	-
B-8591 BLK	Outdoor Polyester	-	-	-	-	-	-	-	-	-	● UL	-	-	-	-	-	-	-

For further material compatibility related to UL/CSA, see pages 18-22 or refer to Brady Tech Data Sheet for complete material performance specifications

# LABEL MATERIALS



## Materials for every application

Successful projects start (and end) with Brady materials. Optimum performance and durability are assured with each.

			Color	Permanent	Removable	Matte	Gloss	Service Temperature	Regulations	Page #
B-342	PermaSleeve® Heat-Shrink Sleeves	Heat-shrinkable polyolefin wire and cable marking sleeve with a 3:1 shrink ratio. Fade-resistant and flame-retardant industrial, military grade sleeve.	● ● ●	•		•		-67° to 275°F	UL RoHS	48, 49
B-344	PermaSleeve® Fluid Resistant Heat-Shrink Sleeves	Heat-shrinkable, fluid-resistant polyolefin wire and cable marking sleeve with a 2:1 shrink ratio. Designed for exposure to fluids, lubricants and harsh chemicals such as in the installation of hydrogen fuel cells in aerospace.	● ● ●	•		•		-67° to 275°F	RoHS	50
B-345	PermaSleeve® High Temp Heat-Shrink Sleeves	Heat-shrinkable, high-temperature PVDF wire and cable marking sleeve with a 3:1 shrink ratio. Designed for high-temperature and low-outgassing applications.	● ● ●	•		•		-67° to 437°F	RoHS	51
B-403	Water-Dissolvable Paper	White water-dissolvable paper label for temporary labeling applications that require easy cleaning. Ideal for laboratory glassware.	○	•		•		-94° to 122°F	RoHS	68
B-413	Matte Faux Metallized Polyester	Silver polyester label with a strong, permanent adhesive and a metal appearance, but NON-METAL construction. Adhesive designed for flat surfaces that are textured or require increased adhesion. Ideal for non-metal applications for PCB and component identification, rating plates and product labels.	●	•		•		-94° to 248°F	UL RoHS	25, 30
B-414	BradyGrip® Print-on Hook Material Featuring VELCRO® Brand Hook	Printable hook label material that affixes to VELCRO® Brand ONE-WRAP® rolls (sold separately). Ideal for repositionable and reusable cable bundle markers.	○		•		•	-40° to 122°F	RoHS	45
B-417	Aggressive Adhesive Self-Laminating Vinyl	Translucent vinyl label with extra strong permanent adhesive. The adhesive is designed to adhere in high humidity conditions, on smaller diameter wires and on challenging wire jacket materials, including Teflon, Silicone, braided and traditional PVC. Self-laminating formats feature a white printable zone and a non-printable clear tail that wraps around a wire, cable or tube to cover the printed, text offering protection from abrasion, water, oil and solvents.	○	•		•		-94° to 158°F	UL RoHS	43
B-422	Aggressive Adhesive Multi-Purpose Polyester	Polyester with a high-gloss finish and a stronger, 2-mil permanent acrylic adhesive. Adhesive is designed for flat surfaces that are textured or require increased adhesion. Ideal for barcoding, asset tracking, product labels and post-process PCB electronic component labeling.	○	•			•	-40° to 212°F	UL RoHS	26, 41
B-423	Multi-Purpose Polyester	Polyester with a high-gloss finish and a permanent acrylic adhesive. Excellent image quality and widely used for barcoding, asset tracking, product labels and post-process PCB electronic component labeling. Adheres best to flat surfaces. UL-rated for surfaces commonly used in solar panel manufacturing.	○	•			•	-94° to 248°F	UL RoHS	24
B-423/ B-966B	PermaShield™ Overlaminating Polyester	The PermaShield™ construction is supplied as a standard B-423 polyester label with matching B-966B clear polyester overlaminated mounted beneath the label. The label is printed, removed from liner and applied to surface, and then the overlaminated is removed and applied over the label protecting printed text.	○	•			•	-94° to 248°F	RoHS	33
B-424	Paper	Bright white paper label with a permanent latex adhesive. Excellent barcode read rates. Ideal for labeling applications requiring a low-cost, general-purpose labeling material.	○	•		•		-40° to 122°F	RoHS	34
B-425A	Chemical Resistant Matte Polypropylene	Polypropylene label with a permanent adhesive and excellent solvent resistance and print performance. Fuel-, oil-, chemical- and low-temperature resistant.	○	•		•		-94° to 212°F	RoHS	32, 61
B-427	Self-Laminating Vinyl	Translucent vinyl label with a permanent adhesive. Self-laminating format features a white printable zone and a non-printable clear tail that wraps around a wire, cable or tube to cover the printed text. Offers protection from abrasion, water, oil and solvents. Material conforms well to curved and rounded surfaces.	○ ○	•		•		-94° to 158°F	UL RoHS	42, 44
B-428	Metallized Matte Polyester	Matte metallized polyester with a permanent adhesive. Light gray, matte appearance. Adheres best to flat surfaces. Ideal for rating plates on products and panels, and general-purpose product labels.	●	•		•		-40° to 293°F	UL RoHS	30

For further ribbon compatibility related to UL / CSA, see pages 16-17 and refer to Brady Tech Data Sheet for complete material performance specifications

			Color	Permanent	Removable	Matte	Gloss	Service Temperature	Regulations	Page #
<b>B-428/ B-966B</b>	PermaShield™ Overlaminating Metallized Polyester	The PermaShield™ construction is supplied as a standard B-428 metallized polyester label with matching B-966B clear polyester overlaminate mounted beneath the label. The label is printed, removed from liner and applied to surface. Then the overlaminate is removed and applied over the label to protect printed text.	●	•		•		-40° to 293°F	RoHS	33
<b>B-430</b>	Multi-Purpose Clear Polyester	Clear polyester with a high-gloss finish and a 1-mil permanent acrylic adhesive. It has excellent image quality and adheres best to flat surfaces.	○	•			•	-40° to 293°F	UL RoHS CE	25
<b>B-432</b>	Aggressive Adhesive Multi-Purpose Clear Polyester	Clear polyester with a high-gloss finish and a stronger, 2-mil permanent acrylic adhesive. It has excellent imaging quality and is designed for flat surfaces that are textured or require increased adhesion.	○	•			•	-40° to 212°F	UL RoHS CE	26
<b>B-434A</b>	Metallized Aggressive Adhesive Polyester	Glossy metallized polyester with a stronger, 2-mil permanent adhesive. It has a high-gloss, silver appearance with excellent image quality. Adhesive is designed for flat surfaces that are textured or require increased adhesion. Ideal for rating plates, general-purpose product labels and asset tracking labels.	●	•			•	-40° to 194°F	UL RoHS CE	31, 40
<b>B-435A</b>	Metallized Polyester	Glossy metallized polyester with a 1-mil permanent adhesive. It has a high-gloss, silver appearance and excellent imaging quality. It adheres best to flat surfaces and is ideal for rating plates and general-purpose product labels.	●	•			•	-40° to 194°F	UL RoHS CE	30
<b>B-437</b>	Self-Extinguishing Tedlar®	Heavy-duty Tedlar® label material with self-extinguishing features for wire and cable wrapping. It has excellent resistance to water, oil, chemicals and abrasion.	○●	•		•		-94° to 275°F	RoHS	47
<b>B-438</b>	Checkerboard Pattern Tamper Evident Matte Metallized Polyester	Tamper-indicating, metallized polyester label that leaves an aggressive checkerboard adhesive pattern on the surface if label is removed. It has a matte, silver appearance with has excellent imaging quality for text, barcodes and symbols. It is designed for rating and serial plates, asset tracking labels and product ID such as warranty labels when anti-tampering and tamper-indicating features are desired.	●	•		•		-40° to 104°F	UL RoHS CE	32
<b>B-439</b>	Multi-Purpose Vinyl	Indoor- and outdoor-grade vinyl with a high-tack permanent adhesive. It is extremely pliable and highly conforming to rough and irregular surfaces, and has good chemical and abrasion resistance. Ideal for general-purpose labeling applications.	○	•			•	-94° to 176°F	RoHS	33, 64
<b>B-443</b>	Aggressive Adhesive Hi-Temp Chemical Resistant Polyester	Very durable matte polyester with excellent high-temp resistance and superior resistance to fluids and chemicals that are not high in pH value. Short term temp resistance to 410° F. Features a hybrid acrylic-rubber-based permanent adhesive and is self-extinguishing.	○	•		•		-94° to 248° F	UL	29
<b>B-461</b>	Self-Laminating Cryogenic Polyester	Ultra-thin profile label with a white printable area and a clear self-laminating tail. The clear label protects print and allows visibility of liquid level in a vial. It has excellent smudge resistance and solvent resistance, and performs well in laboratory environments with liquid nitrogen, autoclave, freezer and hot water bath applications when laminated around itself.	○	•		•		-320° to 320°F check TDS for specific applications	RoHS	66
<b>B-472</b>	High Temp Flame Retardant Polyimide	Heavy-duty, high-temperature label designed to self-extinguish and prevent flames from propagating. This material is flexible, conforming and repositionable for wire and cable wrapping where high-temperature and self-extinguishing properties are required. Excellent resistance to water, oil, chemicals and abrasion.	○●	•		•		-94° to 320°F	RoHS	47
<b>B-473</b>	Standard Adhesive Electrostatic Dissipative Polyester	Glossy polyester label that is ideal for post-process labeling of circuit boards and electronic components. Features both a static dissipative permanent adhesive and a static dissipative release liner. Surface resistivity values are in the recommended range for ESD packing materials. Meets requirement of EIA-541 "Packaging Material Standards for ESD Sensitive Items". This material is ideal for circuit board and component identification, and is fuel, oil, chemical, high- and low-temperature resistant.	○	•			•	-40° to 248°F	UL RoHS CE	29
<b>B-481</b>	StainerBondz™ Microscope Slide Polyester	Designed as a label for microscope slides that are exposed to laboratory staining processes. This material is chemical resistant.	○	•		•		-112° to 266°F	RoHS	65, 68

For further ribbon compatibility related to UL / CSA, see pages 16-17 and refer to Brady Tech Data Sheet for complete material performance specifications

			Color	Permanent	Removable	Matte	Gloss	Service Temperature	Regulations	Page #
<b>B-483A</b>	Ultra Aggressive Adhesive Multi-Purpose Polyester	Polyester with high-gloss finish and ultra-aggressive, permanent acrylic adhesive. Designed for very high adhesion to flat but highly textured or powder-coated surfaces and low-surface-energy surfaces. Gloss version of B-489.	○	•			•	-40° to 248°F	UL RoHS CE	27, 40, 41, 45, 65
<b>B-484A</b>	Flexible Aggressive Adhesive Multi-Purpose Polyester	Polyester with a glossy finish and a stronger, permanent acrylic adhesive. Similar to B-483, but with a thinner construction to facilitate high adhesion to flat, curved or angular surfaces, and surfaces that are textured, powder coated or low-surface energy.	○	•			•	-40° to 248°F	UL RoHS	26, 40, 41
<b>B-486B</b>	Ultra Aggressive Adhesive Metallized Matte Polyester	Matte metallized polyester with an ultra-aggressive, permanent adhesive. It has a light gray, matte appearance. Designed for very high adhesion to flat but highly textured or powder-coated surfaces and low-surface-energy surfaces. Ideal for panel rating plates, product labels and asset-tracking labels.	●	•		•		-40° to 248°F	UL RoHS CE	31, 40
<b>B-489A</b>	Ultra Aggressive Adhesive Multi-Purpose Matte Polyester	Matte polyester with an ultra-aggressive, permanent adhesive. It is designed for very high adhesion to flat but highly textured or powder-coated surfaces and low-surface-energy surfaces. Matte version of B-483.	○	•		•		-94° to 248°F	UL RoHS CE	27
<b>B-490</b>	FreezerBondz™ Cryogenic Polyester	FreezerBondz™ material is designed for use in laboratory identification, including liquid nitrogen and freezer applications. Adheres to room-temperature, frozen or frosted tubes and vials when wrapped around itself by at least 1/8 inch.	○	•		•		-320° to 320°F check TDS for specific applications	RoHS	66
<b>B-492</b>	FreezerBondz™ Ultra-Thin Cryogenic Polyester	Ultra-thin FreezerBondz™ material is designed to withstand extreme laboratory temperatures, including liquid nitrogen and freezer applications. Adheres to room-temperature, frozen or frosted tubes, vials and canes.	○	•		•		-320° to 230°F check TDS for specific applications	RoHS	66
<b>B-494</b>	Colored Lab Polyester	Glossy white polyester with a pre-printed colored border. This material allows for differentiation and color coding of test specimens within processes. In vial and vial top configuration, the vial top label is a solid color. Withstands freezer applications and has superior chemical resistance when printed with the Brady Series R6400 black ribbon.	●●●●	•			•	-320° to 158°F	RoHS	67
<b>B-498</b>	Repositionable Multi-Purpose Vinyl Cloth	Vinyl cloth with an aggressive and repositionable adhesive for wire and cable wraps and general-purpose labeling applications. Label adheres with excellent holding power, yet can be easily and cleanly removed and repositioned.	○	•			•	-40° to 175°F	UL RoHS	41, 46, 64
<b>B-499</b>	Aggressive Adhesive Multi-Purpose Nylon Cloth	Nylon cloth with a permanent adhesive for wire and cable wraps and general-purpose labeling applications. It has a higher upper-temperature limit than vinyl wire labels. Ideal for environments where heat, cold, oil and dirt are present. Also ideal for laboratory vial identification.	○	•			•	-40° to 230°F	UL RoHS CE	41, 46, 64, 67, 69
<b>B-509</b>	Magnetic Polyester (repositionable)	A thick, non-adhesive magnetic material with a printable vinyl topcoat. The easiest and quickest material for repositioning and reusing labels.	○●	•		•		-0° to 158°F	RoHS	62
<b>B-526</b>	BradyGlo™ High Intensity Glow-in-the-Dark Polyester	Printable BradyGlo™ photoluminescent polyester tape is for glow-in-the-dark identification for up to 10 hours. Ideal for marking emergency shut-offs and controls markings, supplemental evacuation labels and marking emergency equipment.	●	•			•	-40° to 140°F	RoHS	61
<b>B-549</b>	Cold Temperature Application Multi-Purpose Polyester	Cold-temperature polyester material permanently adheres to frozen surfaces. Can be applied in temperatures as low as -10°F, and stays adhered in -40°F temperatures.	○●	•		•		-40° to 212°F	RoHS	62
<b>B-569</b>	Low-Halide Multi-Purpose Polyester	Low-halide polyester label material with a permanent adhesive. It is designed for stainless steel pipes and stainless steel surfaces, and is best suited for smooth, clean, flat surfaces.	●●●●●●●●●●	•			•	-40° to 212°F	RoHS	59, 63

For further ribbon compatibility related to UL / CSA, see pages 16-17 and refer to Brady Tech Data Sheet for complete material performance specifications



## Standard Adhesive Polyester Labels (B-423, B-618, B-430, B-413, B-8117)

- For general purpose identification, product labels and post-process circuit board identification
- Adheres best to flat, smooth surfaces. Consult technical data sheet for UL / CSA ratings and complete performance and testing details
- **0.20" dimension parts for use in i5300 only**

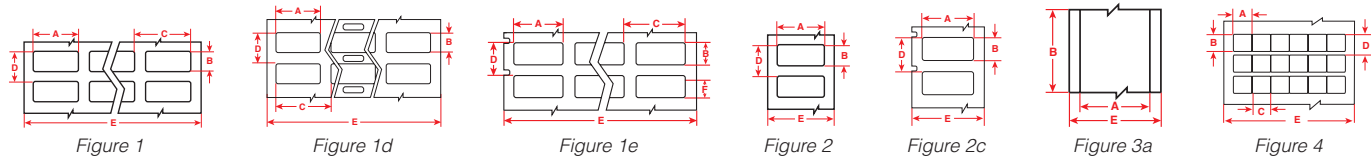
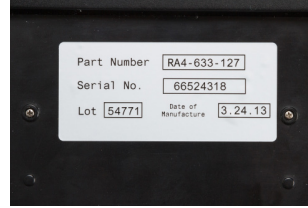

For Use with Printers:	Diagram	Catalog #	Color	Label width A inch (mm)	Label height B inch (mm)	Horiz. repeat C inch (mm)	Vert. repeat D inch (mm)	Web width E inch (mm)	Labels per row	Labels per roll	Rec. ribbon
<b>Multi-purpose gloss polyester (B-423)</b>											
i3300, i5300, BBP33	Fig. 1	B33-70-423	Gloss White	0.250 (6.4)	0.250 (6.4)	0.320 (8.1)	0.350 (8.9)	2.370 (60.1)	7	20000	B30-R6000
i3300, i5300, BBP33	Fig. 4	B33-11-423	Gloss White	0.250 (6.4)	0.250 (6.4)	0.250 (6.4)	0.375 (9.5)	3.200 (81.3)	12	15000	B30-R6000
i3300, i5300, BBP33	Fig. 1	B33-340-423	Gloss White	0.375 (9.5)	0.375 (9.5)	0.438 (11.1)	0.475 (12.1)	3.500 (88.9)	7	10000	B30-R6000
i5300	Fig. 1d	B33-343-423	Gloss White	0.500 (12.7)	0.200 (5.0)	0.625 (15.8)	0.325 (8.2)	3.200 (81.3)	5	10000	B30-R6000
i3300, i5300, BBP33	Fig. 1	B33-12-423	Gloss White	0.500 (12.7)	0.437 (11.0)	0.662 (16.8)	0.537 (13.6)	3.350 (85.1)	5	10000	B30-R6000
i3300, i5300, BBP33	Fig. 1	B33-149-423	Gloss White	0.500 (12.7)	0.500 (12.7)	0.600 (15.2)	0.600 (15.2)	2.500 (63.5)	4	5000	B30-R6000
i5300	Fig. 1d	B33-341-423	Gloss White	0.650 (16.5)	0.200 (5.0)	0.700 (17.7)	0.325 (8.2)	2.950 (74.9)	4	10000	B30-R6000
i3300, i5300, BBP33	Fig. 1	B33-1-423	Gloss White	0.750 (19.1)	0.250 (6.4)	0.800 (20.3)	0.350 (8.9)	3.350 (85.1)	4	5000	B30-R6000
i3300, i5300, BBP33	Fig. 2	B33-46-423	Gloss White	0.750 (19.1)	0.250 (6.4)	-	0.350 (8.9)	0.950 (24.1)	1	5000	B30-R6000
i3300, i5300, BBP33	Fig. 1	B33-2-423	Gloss White	0.900 (22.9)	0.250 (6.4)	1.125 (28.5)	0.350 (8.9)	3.350 (85.1)	3	10000	B30-R6000
i3300, i5300, BBP33	Fig. 2	B33-49-423	Gloss White	0.900 (22.9)	0.250 (6.4)	-	0.350 (8.9)	1.100 (27.9)	1	5000	B30-R6000
i3300, i5300, BBP33	Fig. 1	B33-51-423	Gloss White	1.000 (25.4)	0.250 (6.4)	1.075 (27.3)	0.350 (8.9)	3.350 (85.1)	3	10000	B30-R6000
i3300, i5300, BBP33	Fig. 2	B33-103-423	Gloss White	1.000 (25.4)	0.250 (6.4)	-	0.350 (8.9)	1.200 (30.5)	1	5000	B30-R6000
i3300, i5300, BBP33	Fig. 1	B33-3-423	Gloss White	1.000 (25.4)	0.375 (9.5)	1.075 (27.3)	0.475 (12.1)	3.350 (85.1)	3	5000	B30-R6000
i3300, i5300, BBP33	Fig. 1	B33-5-423	Gloss White	1.000 (25.4)	0.500 (12.7)	1.075 (27.3)	0.600 (15.2)	3.350 (85.1)	3	5000	B30-R6000
i3300, i5300, BBP33	Fig. 1	B33-13-423	Gloss White	1.250 (31.8)	0.250 (6.4)	1.300 (33.0)	0.375 (9.5)	2.750 (69.9)	2	7000	B30-R6000
i3300, i5300, BBP33	Fig. 2	B33-43-423	Gloss White	1.250 (31.8)	0.250 (6.4)	-	0.350 (8.9)	1.450 (36.8)	1	5000	B30-R6000
i3300, i5300, BBP33	Fig. 1	B33-29-423	Gloss White	1.250 (31.8)	0.375 (9.5)	1.300 (33.0)	0.475 (12.1)	2.750 (69.9)	2	5000	B30-R6000
i3300, i5300, BBP33	Fig. 1	B33-4-423	Gloss White	1.500 (38.1)	0.250 (6.4)	1.650 (41.9)	0.350 (8.9)	3.350 (85.1)	2	8000	B30-R6000
i3300, i5300, BBP33	Fig. 2	B33-45-423	Gloss White	1.500 (38.1)	0.250 (6.4)	-	0.350 (8.9)	1.700 (43.2)	1	5000	B30-R6000
i3300, i5300, BBP33	Fig. 1	B33-147-423	Gloss White	1.500 (38.1)	0.375 (9.5)	1.650 (41.9)	0.475 (12.1)	3.350 (85.1)	2	5000	B30-R6000
i3300, i5300, BBP33	Fig. 1	B33-37-423	Gloss White	1.500 (38.1)	0.500 (12.7)	1.650 (41.9)	0.600 (15.2)	3.350 (85.1)	2	5000	B30-R6000
i3300, i5300, BBP33	Fig. 1	B33-6-423	Gloss White	1.500 (38.1)	0.750 (19.1)	1.650 (41.9)	0.875 (22.2)	3.350 (85.1)	2	3300	B30-R6000
i3300, i5300, BBP33	Fig. 2	B33-72-423	Gloss White	1.750 (44.5)	0.250 (6.4)	-	0.350 (8.9)	1.950 (49.5)	1	5000	B30-R6000
i3300, i5300, BBP33	Fig. 2	B33-15-423	Gloss White	2.000 (50.8)	0.250 (6.4)	-	0.375 (9.5)	2.200 (55.9)	1	3200	B30-R6000
i3300, i5300, BBP33	Fig. 2	B33-53-423	Gloss White	2.000 (50.8)	0.500 (12.7)	-	0.600 (15.2)	2.200 (55.9)	1	2500	B30-R6000
i3300, i5300, BBP33	Fig. 2	B33-17-423	Gloss White	2.000 (50.8)	1.000 (25.4)	-	1.125 (28.6)	2.200 (55.9)	1	1500	B30-R6000
i3300, i5300, S3000, S3100, BBP30, BBP31, BBP33, BBP35, BBP37	Fig. 3a	B30C-2000-423	Gloss White	2.000 (50.8)	100 ft. (30.5 m)	-	-	2.250 (57.2)	1 roll (cont.)		B30-R6000
i3300, i5300, BBP33	Fig. 2	B33-7-423	Gloss White	2.750 (69.9)	1.250 (31.8)	-	1.375 (34.9)	2.950 (74.9)	1	1000	B30-R6000
i3300, i5300, BBP33	Fig. 2	B33-18-423	Gloss White	3.000 (76.2)	1.000 (25.4)	-	1.125 (28.6)	3.200 (81.3)	1	1500	B30-R6000
i3300, i5300, S3000, S3100, BBP30, BBP31, BBP33, BBP35, BBP37	Fig. 3a	B30C-3000-423	Gloss White	3.000 (76.2)	100 ft. (30.5 m)	-	-	3.250 (82.6)	1 roll (cont.)		B30-R6000
i3300, i5300, BBP33	Fig. 2	B33-19-423	Gloss White	3.000 (76.2)	2.000 (50.8)	-	2.125 (54.0)	3.200 (81.3)	1	500	B30-R6000
i3300, i5300, BBP33	Fig. 2	B33-20-423	Gloss White	3.000 (76.2)	5.000 (127.0)	-	5.125 (130.1)	3.200 (81.3)	1	350	B30-R6000
i3300, i5300, S3000, S3100, BBP30, BBP31, BBP33, BBP35, BBP37	Fig. 3a	B30C-4000-423	Gloss White	4.000 (101.6)	100 ft. (30.5 m)	-	-	4.200 (106.7)	1 roll (cont.)		B30-R6000
i3300, i5300, BBP33	Fig. 2	B33-55-423	Gloss White	4.000 (101.6)	2.000 (50.8)	-	2.125 (54.0)	4.200 (106.7)	1	750	B30-R6000
i3300, i5300, BBP33	Fig. 2	B33-76-423	Gloss White	4.000 (101.6)	3.000 (76.2)	-	3.125 (79.3)	4.200 (106.7)	1	500	B30-R6000
i3300, i5300, BBP33	Fig. 2	B33-161-423	Gloss White	4.000 (101.6)	4.000 (101.6)	-	4.125 (104.7)	4.200 (106.7)	1	450	B30-R6000
i3300, i5300, BBP33	Fig. 2	B33-25-423	Gloss White	4.000 (101.6)	6.000 (152.4)	-	6.125 (155.5)	4.200 (106.7)	1	300	B30-R6000
<b>Multi-purpose matte polyester (B-618)</b>											
i3300, i5300, BBP33	Fig. 1	B33-12-618	Matte White	0.500 (12.7)	0.437 (11.0)	0.662 (16.8)	0.537 (13.6)	3.350 (85.1)	5	10000	B30-R6000
i3300, i5300, BBP33	Fig. 1	B33-5-618	Matte White	1.000 (25.4)	0.500 (12.7)	1.075 (27.3)	0.600 (15.2)	3.350 (85.1)	3	7000	B30-R6000
i3300, i5300, BBP33	Fig. 1	B33-37-618	Matte White	1.500 (38.1)	0.500 (12.7)	1.650 (41.9)	0.600 (15.2)	3.350 (85.1)	2	5000	B30-R6000
i3300, i5300, BBP33	Fig. 1	B33-6-618	Matte White	1.500 (38.1)	0.750 (19.1)	1.650 (41.9)	0.875 (22.2)	3.350 (85.1)	2	3300	B30-R6000
i3300, i5300, BBP33	Fig. 2	B33-53-618	Matte White	2.000 (50.8)	0.500 (12.7)	-	0.600 (15.2)	2.200 (55.9)	1	2500	B30-R6000
i3300, i5300, BBP33	Fig. 2	B33-17-618	Matte White	2.000 (50.8)	1.000 (25.4)	-	1.125 (28.5)	2.200 (55.9)	1	1500	B30-R6000
i3300, i5300, BBP33	Fig. 2	B33-7-618	Matte White	2.750 (69.9)	1.250 (31.8)	-	1.375 (34.9)	2.950 (74.9)	1	1000	B30-R6000
i3300, i5300, BBP33	Fig. 2	B33-18-618	Matte White	3.000 (76.2)	1.000 (25.4)	-	1.125 (28.5)	3.350 (85.1)	1	1500	B30-R6000
i3300, i5300, BBP33	Fig. 2	B33-19-618	Matte White	3.000 (76.2)	2.000 (50.8)	-	2.125 (53.9)	3.200 (81.3)	1	700	B30-R6000
i3300, i5300, BBP33	Fig. 2	B33-55-618	Matte White	4.000 (101.6)	2.000 (50.8)	-	2.125 (53.9)	4.200 (106.7)	1	750	B30-R6000
i3300, i5300, BBP33	Fig. 2	B33-76-618	Matte White	4.000 (101.6)	3.000 (76.2)	-	3.125 (79.3)	4.200 (106.7)	1	500	B30-R6000

For Use with Printers:	Diagram	Catalog #	Color	Label width A inch (mm)	Label height B inch (mm)	Horiz. repeat C inch (mm)	Vert. repeat D inch (mm)	Web width E inch (mm)	Labels per row	Labels per roll	Rec. ribbon
<b>Multi-purpose gloss clear polyester (B-430)</b>											
i3300, i5300, BBP33	Fig. 1e	B33-12-430	Clear	0.500 (12.7)	0.437 (11.0)	0.662 (16.8)	0.537 (13.6)	3.350 (85.1)	5	10000	B30-R6000
i3300, i5300, BBP33	Fig. 1e	B33-5-430	Clear	1.000 (25.4)	0.500 (12.7)	1.075 (27.3)	0.625 (15.9)	3.350 (85.1)	3	5000	B30-R6000
i3300, i5300, BBP33	Fig. 1e	B33-37-430	Clear	1.500 (38.1)	0.500 (12.7)	1.650 (41.9)	0.600 (15.2)	3.350 (85.1)	2	5000	B30-R6000
i3300, i5300, BBP33	Fig. 1e	B33-6-430	Clear	1.500 (38.1)	0.750 (19.1)	1.650 (41.9)	0.875 (22.2)	3.350 (85.1)	2	3300	B30-R6000
i3300, i5300, BBP33	Fig. 2c	B33-53-430	Clear	2.000 (50.8)	0.500 (12.7)	-	0.600 (15.2)	2.200 (55.9)	1	2500	B30-R6000
i3300, i5300, BBP33	Fig. 2c	B33-17-430	Clear	2.000 (50.8)	1.000 (25.4)	-	1.125 (28.6)	2.200 (55.9)	1	1500	B30-R6000
i3300, i5300, BBP33	Fig. 2c	B33-7-430	Clear	2.750 (69.9)	1.250 (31.8)	-	1.375 (34.9)	2.950 (74.9)	1	1000	B30-R6000
i3300, i5300, BBP33	Fig. 2c	B33-18-430	Clear	3.000 (76.2)	1.000 (25.4)	-	1.125 (28.6)	3.200 (81.3)	1	1500	B30-R6000
i3300, i5300, BBP33	Fig. 3a	B33C-3000-430	Clear	3.000 (76.2)	100 ft. (30.5 m)	-	-	3.200 (81.3)	1 roll (cont.)		B30-R6000
i3300, i5300, BBP33	Fig. 2c	B33-19-430	Clear	3.000 (76.2)	2.000 (50.8)	-	2.125 (53.9)	3.200 (81.3)	1	700	B30-R6000
<b>Multi-purpose matte black polyester (B-8117)</b>											
i3300, i5300, BBP33	Fig. 1	B33-70-8117	Matte Black	0.250 (6.4)	0.250 (6.4)	0.320 (8.1)	0.350 (8.9)	2.370 (60.1)	7	20000	B30-R6800-WT
i3300, i5300, BBP33	Fig. 1	B33-12-8117	Matte Black	0.500 (12.7)	0.437 (11.0)	0.662 (16.8)	0.537 (13.6)	3.350 (85.1)	5	10000	B30-R6800-WT
i5300	Fig. 1d	B33-341-8117	Matte Black	0.650 (16.5)	0.200 (5.0)	0.700 (17.7)	0.325 (8.2)	2.950 (74.9)	4	10000	B30-R6800-WT
i3300, i5300, BBP33	Fig. 1	B33-1-8117	Matte Black	0.750 (19.1)	0.250 (6.4)	0.800 (20.3)	0.350 (8.9)	3.350 (85.1)	4	10000	B30-R6800-WT
i3300, i5300, BBP33	Fig. 1	B33-3-8117	Matte Black	1.000 (25.4)	0.375 (9.5)	1.075 (27.3)	0.475 (12.1)	3.350 (85.1)	3	7000	B30-R6800-WT
i3300, i5300, BBP33	Fig. 1	B33-5-8117	Matte Black	1.000 (25.4)	0.500 (12.7)	1.075 (27.3)	0.600 (15.2)	3.350 (85.1)	3	5000	B30-R6800-WT
i3300, i5300, BBP33	Fig. 1	B33-147-8117	Matte Black	1.500 (38.1)	0.375 (9.5)	1.650 (41.9)	0.475 (12.1)	3.350 (85.1)	2	5000	B30-R6800-WT
i3300, i5300, BBP33	Fig. 1	B33-37-8117	Matte Black	1.500 (38.1)	0.500 (12.7)	1.650 (41.9)	0.600 (15.2)	3.350 (85.1)	2	3300	B30-R6800-WT
i3300, i5300, BBP33	Fig. 1	B33-6-8117	Matte Black	1.500 (38.1)	0.750 (19.1)	1.650 (41.9)	0.875 (22.2)	3.350 (85.1)	2	2500	B30-R6800-WT
i3300, i5300, BBP33	Fig. 2	B33-53-8117	Matte Black	2.000 (50.8)	0.500 (12.7)	-	0.600 (15.2)	2.200 (55.9)	1	1900	B30-R68

## Aggressive Adhesive Polyester Labels (B-422, B-432, B-484A)

- For general purpose identification, product labels, rating plates and post-process circuit board ID
- For adhesion to flat and smooth or textured surfaces. Consult technical data sheet for UL / CSA ratings and complete performance and testing details

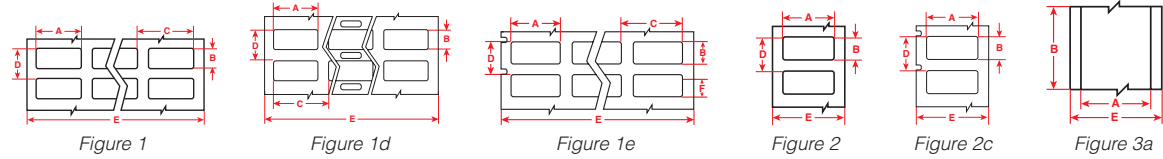

For Use with Printers:	Diagram	Catalog #	Color	Label width A inch (mm)	Label height B inch (mm)	Horiz. repeat C inch (mm)	Vert. repeat D inch (mm)	Web width E inch (mm)	Labels per row	Labels per roll	Rec. ribbon
<b>Gloss polyester with aggressive adhesive for textured surfaces (B-422)</b>											
i3300, i5300, BBP33	Fig. 1	B33-70-422	Gloss White	0.250 (6.4)	0.250 (6.4)	0.320 (8.1)	0.350 (8.9)	2.370 (60.1)	7	20000	B30-R6000
i3300, i5300, BBP33	Fig. 1	B33-340-422	Gloss White	0.375 (9.5)	0.375 (9.5)	0.438 (11.1)	0.475 (12.1)	3.500 (88.9)	7	10000	B30-R6000
i5300	Fig. 1d	B33-343-422	Gloss White	0.500 (12.7)	0.200 (5.0)	0.625 (15.8)	0.325 (8.2)	3.200 (81.3)	5	10000	B30-R6000
i3300, i5300, BBP33	Fig. 1	B33-12-422	Gloss White	0.500 (12.7)	0.437 (11.0)	0.662 (16.8)	0.537 (13.6)	3.350 (85.1)	5	10000	B30-R6000
i3300, i5300, BBP33	Fig. 1	B33-149-422	Gloss White	0.500 (12.7)	0.500 (12.7)	0.600 (15.2)	0.600 (15.2)	2.500 (63.5)	4	5000	B30-R6000
i5300	Fig. 1d	B33-341-422	Gloss White	0.650 (16.5)	0.200 (5.0)	0.700 (17.7)	0.325 (8.2)	2.950 (74.9)	4	10000	B30-R6000
i3300, i5300, BBP33	Fig. 1	B33-1-422	Gloss White	0.750 (19.1)	0.250 (6.4)	0.800 (20.3)	0.350 (8.9)	3.350 (85.1)	4	10000	B30-R6000
i3300, i5300, BBP33	Fig. 1	B33-2-422	Gloss White	0.900 (22.9)	0.250 (6.4)	1.125 (28.5)	0.350 (8.9)	3.350 (85.1)	3	10000	B30-R6000
i3300, i5300, BBP33	Fig. 1	B33-51-422	Gloss White	1.000 (25.4)	0.250 (6.4)	1.075 (27.3)	0.350 (8.9)	3.350 (85.1)	3	10000	B30-R6000
i3300, i5300, BBP33	Fig. 1	B33-3-422	Gloss White	1.000 (25.4)	0.375 (9.5)	1.075 (27.3)	0.475 (12.1)	3.350 (85.1)	3	7000	B30-R6000
i3300, i5300, BBP33	Fig. 1	B33-5-422	Gloss White	1.000 (25.4)	0.500 (12.7)	1.075 (27.3)	0.600 (15.2)	3.350 (85.1)	3	5000	B30-R6000
i3300, i5300, BBP33	Fig. 1	B33-13-422	Gloss White	1.250 (31.8)	0.250 (6.4)	1.300 (33.0)	0.375 (9.5)	2.750 (69.9)	2	7000	B30-R6000
i3300, i5300, BBP33	Fig. 1	B33-147-422	Gloss White	1.500 (38.1)	0.375 (9.5)	1.650 (41.9)	0.475 (12.1)	3.350 (85.1)	2	2500	B30-R6000
i3300, i5300, BBP33	Fig. 2	B33-102-422	Gloss White	1.500 (38.1)	0.375 (9.5)	-	0.500 (12.7)	1.700 (43.2)	1	2500	B30-R6000
i3300, i5300, BBP33	Fig. 1	B33-37-422	Gloss White	1.500 (38.1)	0.500 (12.7)	1.650 (41.9)	0.600 (15.2)	3.350 (85.1)	2	3500	B30-R6000
i3300, i5300, BBP33	Fig. 1	B33-6-422	Gloss White	1.500 (38.1)	0.750 (19.1)	1.650 (41.9)	0.875 (22.2)	3.350 (85.1)	2	3300	B30-R6000
i3300, i5300, BBP33	Fig. 2	B33-136-422	Gloss White	1.500 (38.1)	0.750 (19.1)	-	0.875 (22.2)	1.700 (43.2)	1	1500	B30-R6000
i3300, i5300, BBP33	Fig. 2	B33-15-422	Gloss White	2.000 (50.8)	0.250 (6.4)	-	0.375 (9.5)	2.200 (55.9)	1	3200	B30-R6000
i3300, i5300, BBP33	Fig. 2	B33-53-422	Gloss White	2.000 (50.8)	0.500 (12.7)	-	0.600 (15.2)	2.200 (55.9)	1	2500	B30-R6000
i3300, i5300, BBP33	Fig. 2	B33-17-422	Gloss White	2.000 (50.8)	1.000 (25.4)	-	1.125 (28.6)	2.200 (55.9)	1	1500	B30-R6000
i3300, i5300, BBP33	Fig. 2	B33-7-422	Gloss White	2.750 (69.9)	1.250 (31.8)	-	1.375 (34.9)	2.950 (74.9)	1	1000	B30-R6000
i3300, i5300, BBP33	Fig. 2	B33-18-422	Gloss White	3.000 (76.2)	1.000 (25.4)	-	1.125 (28.6)	3.200 (81.3)	1	1500	B30-R6000
i3300, i5300, BBP33	Fig. 2	B33-19-422	Gloss White	3.000 (76.2)	2.000 (50.8)	-	2.125 (54.0)	3.200 (81.3)	1	500	B30-R6000
i3300, i5300, BBP33	Fig. 2	B33-55-422	Gloss White	4.000 (101.6)	2.000 (50.8)	-	2.125 (53.9)	4.200 (106.7)	1	500	B30-R6000
i3300, i5300, BBP33	Fig. 2	B33-76-422	Gloss White	4.000 (101.6)	3.000 (76.2)	-	3.125 (79.4)	4.200 (106.7)	1	500	B30-R6000
<b>High adhesion clear polyester with stronger adhesive for textured surfaces (B-432)</b>											
i3300, i5300, BBP33	Fig. 1e	B33-12-432	Clear	0.500 (12.7)	0.437 (11.0)	0.662 (16.8)	0.537 (13.6)	3.350 (85.1)	5	10000	B30-R6000
i3300, i5300, BBP33	Fig. 1e	B33-149-432	Clear	0.500 (12.7)	0.500 (12.7)	0.600 (15.2)	0.625 (15.9)	2.500 (63.5)	4	5000	B30-R6000
i3300, i5300, BBP33	Fig. 1e	B33-5-432	Clear	1.000 (25.4)	0.500 (12.7)	1.075 (27.3)	0.600 (15.2)	3.350 (85.1)	3	1500	B30-R6000
i3300, i5300, BBP33	Fig. 1e	B33-37-432	Clear	1.500 (38.1)	0.500 (12.7)	1.650 (41.9)	0.600 (15.2)	3.350 (85.1)	2	5000	B30-R6000
i3300, i5300, BBP33	Fig. 1e	B33-6-432	Clear	1.500 (38.1)	0.750 (19.1)	1.650 (41.9)	0.875 (22.2)	3.350 (85.1)	2	3300	B30-R6000
i3300, i5300, BBP33	Fig. 2c	B33-53-432	Clear	2.000 (50.8)	0.500 (12.7)	-	0.600 (15.2)	2.200 (55.9)	1	2500	B30-R6000
i3300, i5300, BBP33	Fig. 2c	B33-17-432	Clear	2.000 (50.8)	1.000 (25.4)	-	1.125 (28.6)	2.200 (55.9)	1	1500	B30-R6000
i3300, i5300, BBP33	Fig. 2c	B33-7-432	Clear	2.750 (69.9)	1.250 (31.8)	-	1.375 (34.9)	2.950 (74.9)	1	1000	B30-R6000
i3300, i5300, BBP33	Fig. 2c	B33-18-432	Clear	3.000 (76.2)	1.000 (25.4)	-	1.125 (28.6)	3.200 (81.3)	1	1500	B30-R6000
i3300, i5300, BBP33	Fig. 2c	B33-19-432	Clear	3.000 (76.2)	2.000 (50.8)	-	2.125 (54.0)	3.200 (81.3)	1	500	B30-R6000
i3300, i5300, S3000, S3100, BBP30, BBP31, BBP33, BBP35, BBP37	Fig. 3a	B30C-4000-432	Clear	4.000 (101.6)	100 ft. (30.5 m)	-	-	4.250 (108.0)	1 roll (cont.)		B30-R6000
<b>High adhesion flexible polyester for conforming to textured and angular or uneven surfaces (B-484A)</b>											
i3300, i5300, BBP33	Fig. 2	B33-125-484	Gloss White	0.900 (22.9)	0.500 (12.7)	-	0.600 (15.2)	1.100 (27.9)	1	1500	B30-R6000
i3300, i5300, BBP33	Fig. 1	B33-5-484	Gloss White	1.000 (25.4)	0.500 (12.7)	1.075 (27.3)	0.600 (15.2)	3.350 (85.1)	3	5000	B30-R6000
i3300, i5300, BBP33	Fig. 2	B33-136-484	Gloss White	1.500 (38.1)	0.750 (19.1)	-	0.875 (22.2)	1.700 (43.2)	1	1500	B30-R6000
i3300, i5300, BBP33	Fig. 2	B33-17-484	Gloss White	2.000 (50.8)	1.000 (25.4)	-	1.125 (28.6)	2.200 (55.9)	1	1500	B30-R6000
i3300, i5300, BBP33	Fig. 2	B33-18-484	Gloss White	3.000 (76.2)	1.000 (25.4)	-	1.125 (28.6)	3.200 (81.3)	1	1500	B30-R6000
i3300, i5300, BBP33	Fig. 2	B33-19-484	Gloss White	3.000 (76.2)	2.000 (50.8)	-	2.125 (54.0)	3.200 (81.3)	1	500	B30-R6000
i3300, i5300, S3000, S3100, BBP35, BBP37	Fig. 3a	B30C-4000-484	Gloss White	4.000 (101.6)	100 ft. (30.5 m)	-	-	4.200 (106.7)	1 roll (cont.)		B30-R6000
i3300, i5300, BBP33	Fig. 2	B33-55-484	Gloss White	4.000 (101.6)	2.000 (50.8)	-	2.125 (53.9)	4.200 (106.7)	1	750	B30-R6000
i3300, i5300, BBP33	Fig. 2	B33-76-484	Gloss White	4.000 (101.6)	3.000 (76.2)	-	3.125 (79.3)	4.200 (106.7)	1	600	B30-R6000
i3300, i5300, BBP33	Fig. 2	B33-161-484	Gloss White	4.000 (101.6)	4.000 (101.6)	-	4.125 (104.7)	4.200 (106.7)	1	350	B30-R6000
i3300, i5300, BBP33	Fig. 2	B33-25-484	Gloss White	4.000 (101.6)	6.000 (152.4)	-	6.125 (155.5)	4.200 (106.7)	1	325	B30-R6000

## Ultra Aggressive Adhesive Polyester Labels (B-483A, B-489A)

- Ideal for general purpose identification, product labels, rating plates and post-process circuit board ID
- Very high adhesion to flat and smooth or highly textured, rough or powder-coated surfaces. Consult technical data sheet for UL / CSA ratings and complete performance and testing details

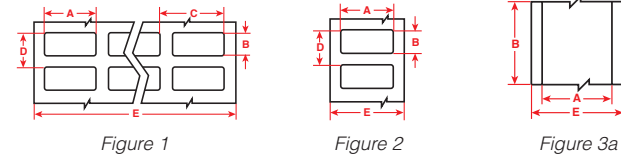

For Use with Printers:	Diagram	Catalog #	Color	Label width A inch (mm)	Label height B inch (mm)	Horiz. repeat C inch (mm)	Vert. repeat D inch (mm)	Web width E inch (mm)	Labels per row	Labels per roll	Rec. ribbon
<b>Gloss polyester with ultra aggressive adhesive for highly textured surfaces (B-483A)</b>											
i3300, i5300, BBP33	Fig. 1	B33-12-483	Gloss White	0.500 (12.7)	0.437 (11.0)	0.662 (16.8)	0.537 (13.6)	3.350 (85.1)	5	10000	B30-R6000
i3300, i5300, BBP33	Fig. 1	B33-149-483	Gloss White	0.500 (12.7)	0.500 (12.7)	0.600 (15.2)	0.600 (15.2)	2.500 (63.5)	4	5000	B30-R6000
i3300, i5300, BBP33	Fig. 1	B33-5-483	Gloss White	1.000 (25.4)	0.500 (12.7)	1.075 (27.3)	0.600 (15.2)	3.350 (85.1)	3	5000	B30-R6000
i3300, i5300, BBP33	Fig. 1	B33-37-483	Gloss White	1.500 (38.1)	0.500 (12.7)	1.650 (41.9)	0.600 (15.2)	3.350 (85.1)	2	5000	B30-R6000
i3300, i5300, BBP33	Fig. 1	B33-6-483	Gloss White	1.500 (38.1)	0.750 (19.1)	1.650 (41.9)	0.875 (22.2)	3.350 (85.1)	2	3300	B30-R6000
i3300, i5300, BBP33	Fig. 2	B33-53-483	Gloss White	2.000 (50.8)	0.500 (12.7)	-	0.600 (15.2)	2.200 (55.9)	1	2500	B30-R6000
i3300, i5300, BBP33	Fig. 2	B33-17-483	Gloss White	2.000 (50.8)	1.000 (25.4)	-	1.125 (28.6)	2.200 (55.9)	1	1500	B30-R6000
i3300, i5300, BBP33	Fig. 2	B33-7-483	Gloss White	2.750 (69.9)	1.250 (31.8)	-	1.375 (34.9)	2.950 (74.9)	1	1000	B30-R6000
i3300, i5300, BBP33	Fig. 2	B33-18-483	Gloss White	3.000 (76.2)	1.000 (25.4)	-	1.125 (28.6)	3.200 (81.3)	1	1500	B30-R6000
i3300, i5300, BBP33	Fig. 2	B33-19-483	Gloss White	3.000 (76.2)	2.000 (50.8)	-	2.125 (54.0)	3.200 (81.3)	1	500	B30-R6000
i3300, i5300, S3000, S3100, BBP35, BBP37	Fig. 3a	B30C-4000-483	Gloss White	4.000 (101.6)	100 ft. (30.5 m)	-	-	4.200 (106.7)	1 roll (cont.)		B30-R6000
i3300, i5300, BBP33	Fig. 2	B33-55-483	Gloss White	4.000 (101.6)	2.000 (50.8)	-	2.125 (54.0)	4.200 (106.7)	1	750	B30-R6000
i3300, i5300, BBP33	Fig. 2	B33-76-483	Gloss White	4.000 (101.6)	3.000 (76.2)	-	3.125 (79.3)	4.200 (106.7)	1	500	B30-R6000
<b>Matte polyester with ultra aggressive adhesive for highly textured surfaces (B-489A)</b>											
i3300, i5300, BBP33	Fig. 1	B33-12-489	Matte White	0.500 (12.7)	0.437 (11.0)	0.662 (16.8)	0.537 (13.6)	3.350 (85.1)	5	10000	B30-R4300
i3300, i5300, BBP33	Fig. 1	B33-5-489	Matte White	1.000 (25.4)	0.500 (12.7)	1.075 (27.3)	0.600 (15.2)	3.350 (85.1)	3	5000	B30-R4300
i3300, i5300, BBP33	Fig. 1	B33-37-489	Matte White	1.500 (38.1)	0.500 (12.7)	1.650 (41.9)	0.600 (15.2)	3.350 (85.1)	2	5000	B30-R4300
i3300, i5300, BBP33	Fig. 1	B33-6-489	Matte White	1.500 (38.1)	0.750 (19.1)	1.650 (41.9)	0.875 (22.2)	3.350 (85.1)	2	3300	B30-R4300
i3300, i5300, BBP33	Fig. 2	B33-53-489	Matte White	2.000 (50.8)	0.500 (12.7)	-	0.600 (15.2)	2.200 (55.9)	1	2500	B30-R4300
i3300, i5300, BBP33	Fig. 2	B33-17-489	Matte White	2.000 (50.8)	1.000 (25.4)	-	1.125 (28.6)	2.200 (55.9)	1	1500	B30-R4300
i3300, i5300, BBP33	Fig. 2	B33-7-489	Matte White	2.750 (69.9)	1.250 (31.8)	-	1.375 (34.9)	2.950 (74.9)	1	1000	B30-R4300
i3300, i5300, BBP33											

## Aggressive Adhesive All-Weather 12-Year Outdoor Polyester (B-8591)

- Outdoor durable low-halogen polyester that resists UV, abrasion and fluids for 12-year average outdoor durability
- Adheres best to flat surfaces and is ideal for outdoor panels, enclosures and equipment
- Consult technical data sheet for UL / CSA ratings, approved print ribbons, and complete weatherability and chemical testing details

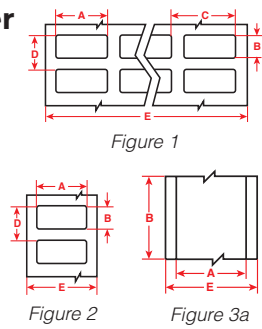

## Aggressive Adhesive, High-Temp Chemical-Resistant Polyester (B-443)

- For labeling applications where chemical-resistance, self-extinguishing and short-term high-temp properties are required
- Superior resistance to chemicals and fluids that do not have a high pH value
- Excellent long-term temperature resistance and very high short-term temperature resistance to 410°F
- Best for flat and smooth or textured surfaces
- Consult technical data sheet for complete testing and performance details

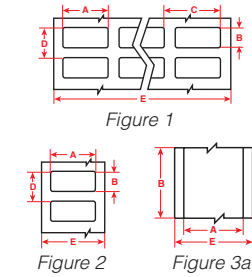

For Use with Printers:	Diagram	Catalog #	Color	Label width A inch (mm)	Label height B inch (mm)	Horiz. repeat C inch (mm)	Vert. repeat D inch (mm)	Web width E inch (mm)	Labels per row	Labels per roll	Rec. ribbon
i3300, i5300, BBP33	Fig. 1	B33-11-8591-WT	White	0.250 (6.4)	0.250 (6.4)	-	0.375 (9.5)	3.200 (81.3)	12	10000	B30-R6600
i3300, i5300, BBP33	Fig. 1	B33-5-8591-WT	White	1.000 (25.4)	0.500 (12.7)	1.075 (27.3)	0.600 (15.2)	3.350 (85.1)	3	7500	B30-R6600
i3300, i5300, BBP33	Fig. 2	B33-179-8591-WT	White	1.000 (25.4)	1.000 (25.4)	-	1.100 (27.9)	1.200 (30.5)	1	1500	B30-R6600
i3300, i5300, BBP33	Fig. 1	B33-37-8591-WT	White	1.500 (38.1)	0.500 (12.7)	1.650 (41.9)	0.600 (15.2)	3.350 (85.1)	2	4000	B30-R6600
i3300, i5300, BBP33	Fig. 1	B33-6-8591-WT	White	1.500 (38.1)	0.750 (19.1)	1.650 (41.9)	0.875 (22.2)	3.350 (85.1)	2	3500	B30-R6600
i3300, i5300, BBP33	Fig. 2	B33-53-8591-WT	White	2.000 (50.8)	0.500 (12.7)	-	0.600 (15.2)	2.200 (55.9)	1	2500	B30-R6600
i3300, i5300, BBP33	Fig. 2	B33-17-8591-WT	White	2.000 (50.8)	1.000 (25.4)	-	1.125 (29.2)	2.200 (55.9)	1	1500	B30-R6600
i3300, i5300, BBP33	Fig. 3a	B33C-2000-8591-WT	White	2.000 (50.8)	100 ft. (30.5 m)	-	-	2.200 (55.9)	1 roll (cont.)	-	B30-R6600
i3300, i5300, BBP33	Fig. 2	B33-7-8591-WT	White	2.750 (69.9)	1.250 (31.8)	-	1.375 (34.9)	2.950 (74.9)	1	1000	B30-R6600
i3300, i5300, BBP33	Fig. 2	B33-18-8591-WT	White	3.000 (76.2)	1.000 (25.4)	-	1.125 (29.2)	3.200 (81.3)	1	1500	B30-R6600
i3300, i5300, BBP33	Fig. 2	B33-19-8591-WT	White	3.000 (76.2)	2.000 (50.8)	-	2.125 (54.0)	3.200 (81.3)	1	750	B30-R6600
i3300, i5300, BBP33	Fig. 2	B33-55-8591-WT	White	4.000 (101.6)	2.000 (50.8)	-	2.125 (54.0)	4.200 (106.7)	1	750	B30-R6600
i3300, i5300, BBP33	Fig. 2	B33-76-8591-WT	White	4.000 (101.6)	3.000 (76.2)	-	3.125 (79.3)	4.200 (106.7)	1	400	B30-R6600
i3300, i5300, BBP33	Fig. 2	B33-161-8591-WT	White	4.000 (101.6)	4.000 (101.6)	-	4.125 (104.8)	4.200 (106.7)	1	400	B30-R6600
i3300, i5300, BBP33	Fig. 2	B33-25-8591-WT	White	4.000 (101.6)	6.000 (152.4)	-	6.125 (155.6)	4.200 (106.7)	1	250	B30-R6600
i3300, i5300, BBP33	Fig. 1	B33-11-8591-BK	Black	0.250 (6.4)	0.250 (6.4)	-	0.375 (9.5)	3.200 (81.3)	12	10000	B30-R4400-WT
i3300, i5300, BBP33	Fig. 1	B33-5-8591-BK	Black	1.000 (25.4)	0.500 (12.7)	1.075 (27.3)	0.600 (15.2)	3.350 (85.1)	3	7500	B30-R4400-WT
i3300, i5300, BBP33	Fig. 2	B33-179-8591-BK	Black	1.000 (25.4)	1.000 (25.4)	-	1.100 (27.9)	1.200 (30.5)	1	1500	B30-R4400-WT
i3300, i5300, BBP33	Fig. 1	B33-37-8591-BK	Black	1.500 (38.1)	0.500 (12.7)	1.650 (41.9)	0.600 (15.2)	3.350 (85.1)	2	4000	B30-R4400-WT
i3300, i5300, BBP33	Fig. 1	B33-6-8591-BK	Black	1.500 (38.1)	0.750 (19.1)	1.650 (41.9)	0.875 (22.2)	3.350 (85.1)	2	3500	B30-R4400-WT
i3300, i5300, BBP33	Fig. 2	B33-53-8591-BK	Black	2.000 (50.8)	0.500 (12.7)	-	0.600 (15.2)	2.200 (55.9)	1	2500	B30-R4400-WT
i3300, i5300, BBP33	Fig. 2	B33-17-8591-BK	Black	2.000 (50.8)	1.000 (25.4)	-	1.125 (29.2)	2.200 (55.9)	1	1500	B30-R4400-WT
i3300, i5300, BBP33	Fig. 3a	B33C-2000-8591-BK	Black	2.000 (50.8)	100 ft. (30.5 m)	-	-	2.200 (55.9)	1 roll (cont.)	-	B30-R4400-WT
i3300, i5300, BBP33	Fig. 2	B33-7-8591-BK	Black	2.750 (69.9)	1.250 (31.8)	-	1.375 (34.9)	2.950 (74.9)	1	1000	B30-R4400-WT
i3300, i5300, BBP33	Fig. 2	B33-18-8591-BK	Black	3.000 (76.2)	1.000 (25.4)	-	-	3.200 (81.3)	1	1500	B30-R4400-WT
i3300, i5300, BBP33	Fig. 2	B33-19-8591-BK	Black	3.000 (76.2)	2.000 (50.8)	-	2.125 (54.0)	3.200 (81.3)	1	750	B30-R4400-WT
i3300, i5300, BBP33	Fig. 2	B33-55-8591-BK	Black	4.000 (101.6)	2.000 (50.8)	-	2.125 (54.0)	4.200 (106.7)	1	750	B30-R4400-WT
i3300, i5300, BBP33	Fig. 2	B33-76-8591-BK	Black	4.000 (101.6)	3.000 (76.2)	-	3.125 (79.3)	4.200 (106.7)	1	400	B30-R4400-WT
i3300, i5300, BBP33	Fig. 2	B33-161-8591-BK	Black	4.000 (101.6)	4.000 (101.6)	-	4.125 (104.8)	4.200 (106.7)	1	400	B30-R4400-WT
i3300, i5300, BBP33	Fig. 2	B33-25-8591-BK	Black	4.000 (101.6)	6.000 (152.4)	-	6.125 (155.6)	4.200 (106.7)	1	250	B30-R4400-WT
i3300, i5300, BBP33	Fig. 1	B33-11-8591-SL	Silver	0.250 (6.4)	0.250 (6.4)	-	0.375 (9.5)	3.200 (81.3)	12	10000	B30-R6600
i3300, i5300, BBP33	Fig. 1	B33-5-8591-SL	Silver	1.000 (25.4)	0.500 (12.7)	1.075 (27.3)	0.600 (15.2)	3.350 (85.1)	3	7500	B30-R6600
i3300, i5300, BBP33	Fig. 2	B33-179-8591-SL	Silver	1.000 (25.4)	1.000 (25.4)	-	1.100 (27.9)	1.200 (30.5)	1	1500	B30-R6600
i3300, i5300, BBP33	Fig. 1	B33-37-8591-SL	Silver	1.500 (38.1)	0.500 (12.7)	1.650 (41.9)	0.600 (15.2)	3.350 (85.1)	2	4000	B30-R6600
i3300, i5300, BBP33	Fig. 1	B33-6-8591-SL	Silver	1.500 (38.1)	0.750 (19.1)	1.650 (41.9)	0.875 (22.2)	3.350 (85.1)	2	3500	B30-R6600
i3300, i5300, BBP33	Fig. 2	B33-53-8591-SL	Silver	2.000 (50.8)	0.500 (12.7)	-	0.600 (15.2)	2.200 (55.9)	1	2500	B30-R6600
i3300, i5300, BBP33	Fig. 2	B33-17-8591-SL	Silver	2.000 (50.8)	1.000 (25.4)	-	1.125 (29.2)	2.200 (55.9)	1	1500	B30-R6600
i3300, i5300, BBP33	Fig. 3a	B33C-2000-8591-SL	Silver	2.000 (50.8)	100 ft. (30.5 m)	-	-	2.200 (55.9)	1 roll (cont.)	-	B30-R6600
i3300, i5300, BBP33	Fig. 2	B33-7-8591-SL	Silver	2.750 (69.9)	1.250 (31.8)	-	1.375 (34.9)	2.950 (74.9)	1	1000	B30-R6600
i3300, i5300, BBP33	Fig. 2	B33-18-8591-SL	Silver	3.000 (76.2)	1.000 (25.4)	-	1.125 (29.2)	3.200 (81.3)	1	1500	B30-R6600
i3300, i5300, BBP33	Fig. 2	B33-19-8591-SL	Silver	3.000 (76.2)	2.000 (50.8)	-	2.125 (54.0)	3.200 (81.3)	1	750	B30-R6600
i3300, i5300, BBP33	Fig. 2	B33-55-8591-SL	Silver	4.000 (101.6)	2.000 (50.8)	-	2.125 (54.0)	4.200 (106.7)	1	750	B30-R6600
i3300, i5300, BBP33	Fig. 2	B33-76-8591-SL	Silver	4.000 (101.6)	3.000 (76.2)	-	3.125 (79.3)	4.200 (106.7)	1	400	B30-R6600
i3300, i5300, BBP33	Fig. 2	B33-161-8591-SL	Silver	4.000 (101.6)	4.000 (101.6)	-	4.125 (104.8)	4.200 (106.7)	1	400	B30-R6600
i3300, i5300, BBP33	Fig. 2	B33-25-8591-SL	Silver	4.000 (101.6)	6.000 (152.4)	-	6.125 (155.6)	4.200 (106.7)	1	250	B30-R6600
i3300, i5300, BBP33	Fig. 1	B33-11-8591-YL	Yellow	0.250 (6.4)	0.250 (6.4)	-	0.375 (9.5)	3.200 (81.3)	12	10000	B30-R6600
i3300, i5300, BBP33	Fig. 1	B33-5-8591-YL	Yellow	1.000 (25.4)	0.500 (12.7)	1.075 (27.3)	0.600 (15.2)	3.350 (85.1)	3	7500	B30-R6600
i3300, i5300, BBP33	Fig. 2	B33-179-8591-YL	Yellow	1.000 (25.4)	1.000 (25.4)	-	1.100 (27.9)	1.200 (30.5)	1	1500	B30-R6600
i3300, i5300, BBP33	Fig. 1	B33-37-8591-YL	Yellow	1.500 (38.1)	0.500 (12.7)	1.650 (41.9)	0.600 (15.2)	3.350 (85.1)	2	4000	B30-R6600
i3300, i5300, BBP33	Fig. 1	B33-6-8591-YL	Yellow	1.500 (38.1)	0.750 (19.1)	1.650 (41.9)	0.875 (22.2)	3.350 (85.1)	2	3500	B30-R6600
i3300, i5300, BBP33	Fig. 2	B33-53-8591-YL	Yellow	2.000 (50.8)	0.500 (12.7)	-	0.600 (15.2)	2.200 (55.9)	1	2500	B30-R6600
i3300, i5300, BBP33	Fig. 2	B33-17-8591-YL	Yellow	2.000 (50.8)	1.000 (25.4)	-	1.125 (29.2)	2.200 (55.9)	1	1500	B30-R6600
i3300, i5300, BBP33	Fig. 1	B33C-2000-8591-YL	Yellow	2.000 (50.8)	100 ft. (30.5 m)	-	-	2.200 (55.9)	1 roll (cont.)	-	B30-R6600
i3300, i5300, BBP33	Fig. 2	B33-7-8591-YL	Yellow	2.750 (69.9)	1.250 (31.8)	-	1.375 (34.9)	2.950 (74.9)	1	1000	B30-R6600
i3300, i5300, BBP33	Fig. 2	B33-18-8591-YL	Yellow	3.000 (76.2)	1.000 (25.4)	-	1.125 (29.2)	3.200 (81.3)	1	1500	B30-R6600
i3300, i5300, BBP33	Fig. 2	B33-19-8591-YL	Yellow	3.000 (76.2)	2.000 (50.8)	-	2.125 (54.0)	3.200 (81.3)	1	750	B30-R6600
i3300, i5300, BBP33	Fig. 2	B33-55-8591-YL	Yellow	4.000 (101.6)	2.000 (50.8)	-	2.125 (54.0)	4.200 (106.7)	1	750	B30-R6600
i3300, i5300, BBP33	Fig. 2	B33-76-8591-YL	Yellow	4.000 (101.6)	3.000 (76.2)	-	3.125 (79.3)	4.200 (106.7)	1	400	B30-R6600
i3300, i5300, BBP33	Fig. 2	B33-161-8591-YL	Yellow	4.000 (101.6)	4.000 (101.6)	-	4.125 (104.8)	4.200 (106.7)	1	400	B30-R6600
i3300, i5300, BBP33	Fig. 2	B33-25-8591-YL	Yellow	4.000 (101.6)	6.000 (152.4)	-	6.125 (155.6)	4.200 (106.7)	1	250	B30-R6600

For Use with Printers:	Diagram	Catalog #	Color	Label width A inch (mm)	Label height B inch (mm)	Horiz. repeat C inch (mm)	Vert. repeat D inch (mm)	Web width E inch (mm)	Labels per row	Labels per roll	Rec. ribbon
i3300, i5300, BBP33	Fig. 1	B33-12-443	Matte White	0.500 (12.7)	0.437 (11.0)	0.662 (16.8)	0.537 (13.6)	3.350 (85.1)	5	10000	B30-R6400
i3300, i5300, BBP33	Fig. 1	B33-5-443	Matte White	1.000 (25.4)	0.500 (12.7)	1.075 (27.3)	0.600 (15.2)	3.350 (85.1)	3	7000	B30-R6400
i3300, i5300, BBP33	Fig. 1	B33-147-443	Matte White	1.500 (38.1)	0.375 (9.5)	1.650 (41.9)	0.475 (12.1)	3.350 (85.1)	2	5000	B30-R6400
i3300, i5300, BBP33	Fig. 1	B33-37-443	Matte White	1.500 (38.1)	0.500 (12.7)	1.650 (41.9)	0.600 (15.2)	3.350 (85.1)	2	5000	B30-R6400
i3300, i5300, BBP33	Fig. 1	B33-6-443	Matte White	1.500 (38.1)	0.750 (19.1)	1.650 (41.9)	0.875 (22.2)	3.350 (85.1)	2	3500	B30-R6400
i3300, i5300, BBP33	Fig. 2	B33-53-443	Matte White	2.000 (50.8)	0.500 (12.7)	-	0.600 (15.2)	2.200 (55.9)	1	2500	B30-R6400
i3300, i5300, BBP33	Fig. 2	B33-17-443	Matte White	2.000 (50.8)	1.000 (25.4)	-	1.125 (28.5)	2.200 (55.9)	1	1500	B30-R6400
i3300, i5300, S3000, S3100, BBP30, BBP31, BBP33, BBP35, BBP37	Fig. 3a	B30C-2000-443	Matte White	2.000 (50.8)	100 ft. (30.5 m)	-	-	2.250 (57.2)	1 roll (cont.)	-	B30-R6400
i3300, i5300, BBP33	Fig. 2	B33-7-443	Matte White	2.750 (69.9)	1.250 (31.8)	-	1.375 (34.9)	2.950 (74.9)	1	1000	B30-R6400
i3300, i5300, BBP33	Fig. 2	B33-18-443	Matte White	3.000 (76.2)	1.000 (25.4)	-	1.125 (28.5)	3.350 (85.1)	1	1500	B30-R6400
i3300, i5300, S3000, S3100, BBP30, BBP31, BBP33, BBP35, BBP37	Fig. 3a	B30C-3000-443	Matte White	3.000 (76.2)	100 ft. (30.5 m)	-	-	3.250 (82.6)	1 roll (cont.)	-	B30-R6400
i3300, i5300, BBP33	Fig. 2	B33-19-443	Matte White	3.000 (76.2)	2.000 (50.8)	-	2.125 (53.9)	3.200 (81.3)	1	700	B30-R6400
i3300, i5300, S3000, S3100, BBP30, BBP31, BBP33, BBP35, BBP37	Fig. 3a	B30C-4000-443	Matte White	4.000 (101.6)	100 ft. (30.5 m)	-	-	4.250 (107.6)	1 roll (cont.)	-	B30-R6400
i3300, i5300, BBP33	Fig. 2	B33-55-443	Matte White	4.000 (101.6)	2.000 (50.8)	-	2.125 (				

## Standard Adhesive Metallized Polyester Labels (B-428, B-435A, B-413, B-8591)

- For labeling applications where a metal label or metal appearance is required
- Ideal for rating plates and product labels
- Adheres best to flat, smooth surfaces
- Consult technical data sheet for UL / CSA ratings and complete performance and testing details

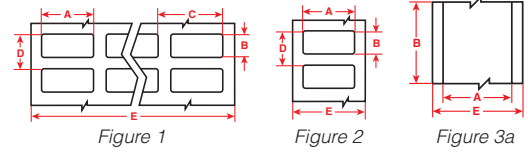

For Use with Printers:	Diagram	Catalog #	Color	Label width A inch (mm)	Label height B inch (mm)	Horiz. repeat C inch (mm)	Vert. repeat D inch (mm)	Web width E inch (mm)	Labels per row	Labels per roll	Rec. ribbon
<b>Matte light gray metallized polyester (B-428)</b>											
i3300, i5300, BBP33	Fig. 1	B33-5-428	Matte Lt. Gray	1.000 (25.4)	0.500 (12.7)	1.075 (27.3)	0.600 (15.2)	3.350 (85.1)	3	5000	B30-R4300
i3300, i5300, BBP33	Fig. 1	B33-37-428	Matte Lt. Gray	1.500 (38.1)	0.500 (12.7)	1.650 (41.9)	0.600 (15.2)	3.350 (85.1)	2	4000	B30-R4300
i3300, i5300, BBP33	Fig. 1	B33-6-428	Matte Lt. Gray	1.500 (38.1)	0.750 (19.1)	1.650 (41.9)	0.875 (22.2)	3.350 (85.1)	2	3000	B30-R4300
i3300, i5300, BBP33	Fig. 2	B33-53-428	Matte Lt. Gray	2.000 (50.8)	0.500 (12.7)	–	0.600 (15.2)	2.200 (55.9)	1	2500	B30-R4300
i3300, i5300, BBP33	Fig. 2	B33-17-428	Matte Lt. Gray	2.000 (50.8)	1.000 (25.4)	–	1.125 (28.6)	2.200 (55.9)	1	1500	B30-R4300
i3300, i5300, S3000, S3100, BBP30, BBP31, BBP33, BBP35, BBP37	Fig. 3a	B30C-2000-428	Matte Lt. Gray	2.000 (50.8)	100 ft. (30.5 m)	–	–	2.250 (57.2)	1 roll (cont.)		B30-R4300
i3300, i5300, BBP33	Fig. 2	B33-7-428	Matte Lt. Gray	2.750 (69.9)	1.250 (31.8)	–	1.375 (34.9)	2.950 (74.9)	1	1000	B30-R4300
i3300, i5300, BBP33	Fig. 2	B33-18-428	Matte Lt. Gray	3.000 (76.2)	1.000 (25.4)	–	1.125 (28.6)	3.200 (81.3)	1	1500	B30-R4300
i3300, i5300, BBP33	Fig. 2	B33-19-428	Matte Lt. Gray	3.000 (76.2)	2.000 (50.8)	–	2.125 (54.0)	3.200 (81.3)	1	500	B30-R4300
i3300, i5300, S3000, S3100, BBP30, BBP31, BBP33, BBP35, BBP37	Fig. 3a	B33C-3000-428	Matte Lt. Gray	3.000 (76.2)	85 ft. (25.9m)	–	–	3.400 (86.4)	1 roll (cont.)		B30-R4300
i3300, i5300, S3000, S3100, BBP30, BBP31, BBP33, BBP35, BBP37	Fig. 3a	B30C-4000-428	Matte Lt. Gray	4.000 (101.6)	130 ft. (39.6m)	–	–	4.200 (106.7)	1 roll (cont.)		B30-R4300
i3300, i5300, BBP33	Fig. 2	B33-55-428	Matte Lt. Gray	4.000 (101.6)	2.000 (50.8)	–	2.125 (53.9)	4.200 (106.7)	1	500	B30-R4300
i3300, i5300, BBP33	Fig. 2	B33-161-428	Matte Lt. Gray	4.000 (101.6)	4.000 (101.6)	–	4.125 (104.7)	4.200 (106.7)	1	300	B30-R4300
<b>High gloss silver metallized polyester (B-435A)</b>											
i3300, i5300, BBP33	Fig. 1	B33-5-435	Gloss Silver	1.000 (25.4)	0.500 (12.7)	1.075 (27.3)	0.600 (15.2)	3.350 (85.1)	3	7000	B30-R6000
i3300, i5300, BBP33	Fig. 1	B33-37-435	Gloss Silver	1.500 (38.1)	0.500 (12.7)	1.650 (41.9)	0.600 (15.2)	3.350 (85.1)	2	5000	B30-R6000
i3300, i5300, BBP33	Fig. 1	B33-6-435	Gloss Silver	1.500 (38.1)	0.750 (19.1)	1.650 (41.9)	0.875 (22.2)	3.350 (85.1)	2	3300	B30-R6000
i3300, i5300, BBP33	Fig. 2	B33-53-435	Gloss Silver	2.000 (50.8)	0.500 (12.7)	–	0.600 (15.2)	2.200 (55.9)	1	2500	B30-R6000
i3300, i5300, BBP33	Fig. 2	B33-17-435	Gloss Silver	2.000 (50.8)	1.000 (25.4)	–	1.125 (28.5)	2.200 (55.9)	1	1500	B30-R6000
i3300, i5300, BBP33	Fig. 3	B33C-2000-435	Gloss Silver	2.000 (50.8)	100 ft. (30.5 m)	–	–	2.200 (55.9)	1 roll (cont.)		B30-R6000
i3300, i5300, BBP33	Fig. 2	B33-7-435	Gloss Silver	2.750 (69.9)	1.250 (31.8)	–	1.375 (34.9)	2.950 (74.9)	1	1000	B30-R6000
i3300, i5300, BBP33	Fig. 2	B33-18-435	Gloss Silver	3.000 (76.2)	1.000 (25.4)	–	1.125 (28.6)	3.200 (81.3)	1	1500	B30-R6000
i3300, i5300, BBP33	Fig. 3a	B33C-3000-435	Gloss Silver	3.000 (76.2)	100 ft. (30.5 m)	–	–	3.200 (81.3)	1 roll (cont.)		B30-R6000
i3300, i5300, BBP33	Fig. 2	B33-19-435	Gloss Silver	3.000 (76.2)	2.000 (50.8)	–	2.125 (54.0)	3.200 (81.3)	1	500	B30-R6000
i3300, i5300, BBP33	Fig. 2	B33-55-435	Gloss Silver	4.000 (101.6)	2.000 (50.8)	–	2.125 (54.0)	4.200 (106.7)	1	750	B30-R6000
i3300, i5300, BBP33	Fig. 2	B33-161-435	Gloss Silver	4.000 (101.6)	4.000 (101.6)	–	4.125 (104.7)	4.200 (106.7)	1	350	B30-R6000
<b>Matte silver metallic-looking polyester but non-metal construction (B-413)</b>											
i3300, i5300, BBP33	Fig. 1	B33-5-413	Matte Silver	1.000 (25.4)	0.500 (12.7)	1.075 (27.3)	0.600 (15.2)	3.350 (85.1)	3	7000	B30-R6000
i3300, i5300, BBP33	Fig. 1	B33-37-413	Matte Silver	1.500 (38.1)	0.500 (12.7)	1.650 (41.9)	0.600 (15.2)	3.350 (85.1)	2	5000	B30-R6000
i3300, i5300, BBP33	Fig. 1	B33-6-413	Matte Silver	1.500 (38.1)	0.750 (19.1)	1.650 (41.9)	0.875 (22.2)	3.350 (85.1)	2	3300	B30-R6000
i3300, i5300, BBP33	Fig. 2	B33-53-413	Matte Silver	2.000 (50.8)	0.500 (12.7)	–	0.600 (15.2)	2.200 (55.9)	1	2500	B30-R6000
i3300, i5300, BBP33	Fig. 2	B33-17-413	Matte Silver	2.000 (50.8)	1.000 (25.4)	–	1.125 (28.5)	2.200 (55.9)	1	1500	B30-R6000
i3300, i5300, BBP33	Fig. 3a	B33C-2000-413	Matte Silver	2.000 (50.8)	100 ft. (30.5 m)	–	–	2.200 (55.9)	1 roll (cont.)		B30-R6000
i3300, i5300, BBP33	Fig. 2	B33-7-413	Matte Silver	2.750 (69.9)	1.250 (31.8)	–	1.375 (34.9)	2.950 (74.9)	1	1000	B30-R6000
i3300, i5300, BBP33	Fig. 2	B33-18-413	Matte Silver	3.000 (76.2)	1.000 (25.4)	–	1.125 (28.5)	3.350 (85.1)	1	1500	B30-R6000
i3300, i5300, BBP33	Fig. 3a	B33C-3000-413	Matte Silver	3.000 (76.2)	100 ft. (30.5 m)	–	–	3.200 (81.3)	1 roll (cont.)		B30-R6000
i3300, i5300, BBP33	Fig. 2	B33-19-413	Matte Silver	3.000 (76.2)	2.000 (50.8)	–	2.125 (53.9)	3.200 (81.3)	1	700	B30-R6000
i3300, i5300, BBP33	Fig. 3a	B33C-4000-413	Matte Silver	4.000 (101.6)	100 ft. (30.5 m)	–	–	4.200 (106.7)	1 roll (cont.)		B30-R6000
i3300, i5300, BBP33	Fig. 2	B33-55-413	Matte Silver	4.000 (101.6)	2.000 (50.8)	–	2.125 (53.9)	4.200 (106.7)	1	750	B30-R6000
<b>Outdoor grade matte silver metallic-looking polyester but non-metal construction (B-8591)</b>											
i3300, i5300, BBP33	Fig. 1	B33-11-8591-SL	Silver	0.250 (6.4)	0.250 (6.4)	–	0.375 (9.5)	3.200 (81.3)	12	10000	B30-R6600
i3300, i5300, BBP33	Fig. 1	B33-5-8591-SL	Silver	1.000 (25.4)	0.500 (12.7)	1.075 (27.3)	0.600 (15.2)	3.350 (85.1)	3	7500	B30-R6600
i3300, i5300, BBP33	Fig. 2	B33-179-8591-SL	Silver	1.000 (25.4)	1.000 (25.4)	–	1.100 (27.9)	1.200 (30.5)	1	1500	B30-R6600
i3300, i5300, BBP33	Fig. 1	B33-37-8591-SL	Silver	1.500 (38.1)	0.500 (12.7)	1.650 (41.9)	0.600 (15.2)	3.350 (85.1)	2	4000	B30-R6600
i3300, i5300, BBP33	Fig. 1	B33-6-8591-SL	Silver	1.500 (38.1)	0.750 (19.1)	1.650 (41.9)	0.875 (22.2)	3.350 (85.1)	2	3500	B30-R6600
i3300, i5300, BBP33	Fig. 2	B33-53-8591-SL	Silver	2.000 (50.8)	0.500 (12.7)	–	0.600 (15.2)	2.200 (55.9)	1	2500	B30-R6600
i3300, i5300, BBP33	Fig. 2	B33-17-8591-SL	Silver	2.000 (50.8)	1.000 (25.4)	–	1.125 (29.2)	2.200 (55.9)	1	1500	B30-R6600
i3300, i5300, BBP33	Fig. 3a	B33C-2000-8591-SL	Silver	2.000 (50.8)	100 ft. (30.5 m)	–	–	2.200 (55.9)	1 roll (cont.)		B30-R6600
i3300, i5300, BBP33	Fig. 2	B33-7-8591-SL	Silver	2.750 (69.9)	1.250 (31.8)	–	1.375 (34.9)	2.950 (74.9)	1	1000	B30-R6600
i3300, i5300, BBP33	Fig. 2	B33-18-8591-SL	Silver	3.000 (76.2)	1.000 (25.4)	–	1.125 (29.2)	3.200 (81.3)	1	1500	B30-R6600
i3300, i5300, BBP33	Fig. 2	B33-19-8591-SL	Silver	3.000 (76.2)	2.000 (50.8)	–	2.125 (54.0)	3.200 (81.3)	1	750	B30-R6600
i3300, i5300, BBP33	Fig. 2	B33-55-8591-SL	Silver	4.000 (101.6)	2.000 (50.8)	–	2.125 (54.0)	4.200 (106.7)	1	750	B30-R6600
i3300, i5300, BBP33	Fig. 2	B33-76-8591-SL	Silver	4.000 (101.6)	3.000 (76.2)	–	3.125 (79.3)	4.200 (106.7)	1	400	B30-R6600
i3300, i5300, BBP33	Fig. 2	B33-161-8591-SL	Silver	4.000 (101.6)	4.000 (101.6)	–	4.125 (104.8)	4.200 (106.7)	1	400	B30-R6600
i3300, i5300, BBP33	Fig. 2	B33-25-8591-SL	Silver	4.000 (101.6)	6.000 (152.4)	–	6.125 (155.6)	4.200 (106.7)	1	250	B30-R6600

## Aggressive Adhesive Metallized Polyester Labels (B-434A)

- Ideal for rating plates and product labels
- Adheres best to flat and smooth or textured surfaces or when extra adhesion is required
- Consult technical data sheet for UL / CSA ratings and complete performance and testing details

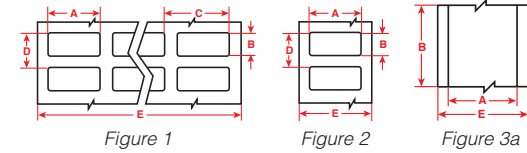

For Use with Printers:	Diagram	Catalog #	Color	Label width A inch (mm)	Label height B inch (mm)	Horiz. repeat C inch (mm)	Vert. repeat D inch (mm)	Web width E inch (mm)	Labels per row	Labels per roll	Rec. ribbon
<b>High gloss silver metallized polyester with aggressive adhesive for textured surfaces (B-434A)</b>											
i3300, i5300, BBP33	Fig. 1	B33-5-434	Gloss Silver	1.000 (25.4)	0.500 (12.7)	1.075 (27.3)	0.600 (15.2)	3.350 (85.1)	3	5000	B30-R6000
i3300, i5300, BBP33	Fig. 1	B33-37-434	Gloss Silver	1.500 (38.1)	0.500 (12.7)	1.650 (41.9)	0.600 (15.2)	3.350 (85.1)	2	5000	B30-R6000
i3300, i5300, BBP33	Fig. 1	B33-6-434	Gloss Silver	1.500 (38.1)	0.750 (19.1)	1.650 (41.9)	0.875 (22.2)	3.350 (85.1)	2	3300	B30-R6000
i3300, i5300, BBP33	Fig. 2	B33-136-434	Gloss Silver	1.500 (38.1)	0.750 (19.1)	–	0.875 (22.2)	1.700 (43.2)	1	1500	B30-R6000
i3300, i5300, BBP33	Fig. 2	B33-53-434	Gloss Silver	2.000 (50.8)	0.500 (12.7)	–	0.600 (15.2)	2.200 (55.9)	1	2500	B30-R6000
i3300, i5300, BBP33	Fig. 2	B33-17-434	Gloss Silver	2.000 (50.8)	1.000 (25.4)	–	1.125 (28.6)	2.200 (55.9)	1	1500	B30-R6000
i3300, i5300, S3000, S3100, BBP30, BBP31, BBP33, BBP35, BBP37	Fig. 3a	B30C-2000-434	Gloss Silver	2.000 (50.8)	100 ft. (30.5 m)	–	–	2.250 (57.2)	1 roll (cont.)		B30-R6000
i3300, i5300, BBP33	Fig. 2	B33-7-434	Gloss Silver	2.750 (69.9)	1.250 (31.8)	–	1.375 (34.9)	2.950 (74.9)	1	1000	B30-R6000
i3300, i5300, BBP33	Fig. 2	B33-18-434	Gloss Silver	3.000 (76.2)	1.000 (25.4)	–	1.125 (28.6)	3.200 (81.3)	1	1500	B30-R6000
i3300, i5300, S3000, S3100, BBP30, BBP31, BBP33, BBP35, BBP37	Fig. 3a	B30C-3000-434	Gloss Silver	3.000 (76.2)	100 ft. (30.5 m)	–	–	3.250 (82.6)	1 roll (cont.)		B30-R6000
i3300, i5300, BBP33	Fig. 2	B33-19-434	Gloss Silver	3.000 (76.2)	2.000 (50.8)	–	2.125 (54.0)	3.200 (81.3)	1	500	B30-R6000
i3300, i5300, S3000, S3100, BBP30, BBP31, BBP33, BBP35, BBP37	Fig. 3a	B30C-4000-434	Gloss Silver	4.000 (101.6)	100 ft. (30.5 m)	–	–	4.200 (106.7)	1 roll (cont.)		B30-R6000
i3300, i5300, BBP33	Fig. 2	B33-55-434	Gloss Silver	4.000 (101.6)	2.000 (50.8)	–	2.125 (54.0)	4.200 (106.7)	1	750	B30-R6000
i3300, i5300, BBP33	Fig. 2	B33-76-434	Gloss Silver	4.000 (101.6)	3.000 (76.2)	–	3.125 (79.3)	4.200 (106.7)	1	500	B30-R6000
i3300, i5300, BBP33	Fig. 2	B33-161-434	Gloss Silver	4.000 (101.6)	4.000 (101.6)	–	4.125 (104.7)	4.200 (106.7)	1	350	B30-R6000
i3300, i5300, BBP3											



### Tamper-Evident Checkerboard Pattern Metallized Polyester Labels (B-438)

- Leaves an aggressive adhesive checkerboard pattern on the surface if label is removed with a matching pattern on the removed label to prevent it from being reused
- Ideal for asset tracking labels and warranty labels on products
- Consult technical data sheet for UL / CSA ratings and complete performance and testing details

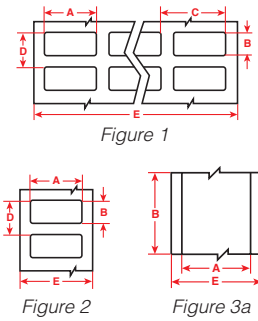

For Use with Printers:	Diagram	Catalog #	Color	Label width A inch (mm)	Label height B inch (mm)	Horiz. repeat C inch (mm)	Vert. repeat D inch (mm)	Web width E inch (mm)	Labels per row	Labels per roll	Rec. ribbon
i3300, i5300, BBP33	Fig. 1	B33-5-438	Matte Silver	1.000 (25.4)	0.500 (12.7)	1.075 (27.3)	0.600 (15.2)	3.350 (85.1)	3	7000	B30-R4300
i3300, i5300, BBP33	Fig. 1	B33-6-438	Matte Silver	1.500 (38.1)	0.500 (12.7)	1.650 (41.9)	0.600 (15.2)	3.350 (85.1)	2	5000	B30-R4300
i3300, i5300, BBP33	Fig. 1	B33-6-438	Matte Silver	1.500 (38.1)	0.750 (19.1)	1.650 (41.9)	0.875 (22.2)	3.350 (85.1)	2	3300	B30-R4300
i3300, i5300, BBP33	Fig. 2	B33-53-438	Matte Silver	2.000 (50.8)	0.500 (12.7)	-	0.600 (15.2)	2.200 (55.9)	1	2500	B30-R4300
i3300, i5300, BBP33	Fig. 2	B30-17-438	Matte Silver	2.000 (50.8)	1.000 (25.4)	-	1.125 (28.6)	2.500 (63.5)	1	1225	B30-R4300
i3300, i5300, BBP33	Fig. 2	B33-7-438	Matte Silver	2.750 (69.9)	1.250 (31.8)	-	1.375 (34.9)	2.950 (74.9)	1	1000	B30-R4300
i3300, i5300, BBP33	Fig. 2	B30-18-438	Matte Silver	3.000 (76.2)	1.000 (25.4)	-	1.250 (31.8)	3.250 (82.6)	1	1225	B30-R4300
i3300, i5300, S3000, S3100, BBP30, BBP31, BBP33, BBP35, BBP37	Fig. 3a	B30C-3000-438-SL	Matte Silver	3.000 (76.2)	100 ft. (30.5 m)	-	-	3.250 (82.6)	1 roll (cont.)		B30-R4300
i3300, i5300, BBP33	Fig. 2	B30-222-438	Matte Silver	3.000 (76.2)	2.000 (50.8)	-	2.250 (57.2)	3.250 (82.6)	1	650	B30-R4300
i3300, i5300, BBP33	Fig. 2	B33-55-438	Matte Silver	4.000 (101.6)	2.000 (50.8)	-	2.125 (53.9)	4.200 (106.7)	1	750	B30-R4300
i3300, i5300, BBP33	Fig. 2	B33-76-438	Matte Silver	4.000 (101.6)	3.000 (76.2)	-	3.125 (79.3)	4.200 (106.7)	1	500	B30-R4300

### Chemical and Solvent Resistant Matte Polypropylene Labels (B-425A)

- Excellent solvent, fuel oil and liquids resistance
- Also has write-on ability for printed labels that require future hand-written data be added
- Flexible material conforms to irregular surfaces better than most polyester materials
- Consult technical data sheet for UL / CSA ratings and complete performance and testing details

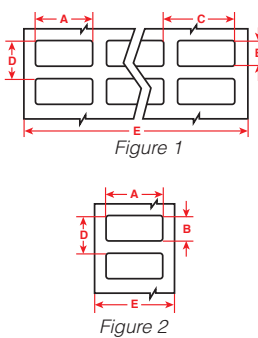

For Use with Printers:	Diagram	Catalog #	Color	Label width A inch (mm)	Label height B inch (mm)	Horiz. repeat C inch (mm)	Vert. repeat D inch (mm)	Web width E inch (mm)	Labels per row	Labels per roll	Rec. ribbon
i3300, i5300, BBP33	Fig. 1	B33-5-425	White	1.000 (25.4)	0.500 (12.7)	1.075 (27.3)	0.600 (15.2)	3.350 (85.1)	3	5000	B30-R4300
i3300, i5300, BBP33	Fig. 1	B33-6-425	White	1.500 (38.1)	0.750 (19.1)	1.650 (41.9)	0.875 (22.2)	3.350 (85.1)	2	3300	B30-R4300
i3300, i5300, BBP33	Fig. 2	B33-53-425	White	2.000 (50.8)	0.500 (12.7)	-	0.600 (15.2)	2.200 (55.9)	1	2000	B30-R4300
i3300, i5300, BBP33	Fig. 2	B33-17-425	White	2.000 (50.8)	1.000 (25.4)	-	1.125 (28.6)	2.200 (55.9)	1	1500	B30-R4300
i3300, i5300, BBP33	Fig. 2	B33-7-425	White	2.750 (69.9)	1.250 (31.8)	-	1.375 (34.9)	2.950 (74.9)	1	1000	B30-R4300
i3300, i5300, BBP33	Fig. 2	B33-18-425	White	3.000 (76.2)	1.000 (25.4)	-	1.125 (28.6)	3.200 (81.3)	1	1500	B30-R4300
i3300, i5300, BBP33	Fig. 2	B33-19-425	White	3.000 (76.2)	2.000 (50.8)	-	2.125 (54.0)	3.200 (81.3)	1	500	B30-R4300
i3300, i5300, BBP33	Fig. 2	B33-20-425	White	3.000 (76.2)	5.000 (127.0)	-	5.125 (130.1)	3.200 (81.3)	1	250	B30-R4300
i3300, i5300, BBP33	Fig. 2	B33-55-425	White	4.000 (101.6)	2.000 (50.8)	-	2.125 (53.9)	4.200 (106.7)	1	600	B30-R4300
i3300, i5300, BBP33	Fig. 2	B33-76-425	White	4.000 (101.6)	3.000 (76.2)	-	3.125 (79.3)	4.200 (106.7)	1	400	B30-R4300

### PermaShield™ Overlaminating Labels with Standard Adhesion (B-423/B-966B, B-428/B-966B)

- Supplied as a standard label with matching clear polyester overlaminate mounted beneath the label
- The label is printed, removed from liner and applied to surface, and then the overlaminate is removed and applied over the label protecting printed text
- Overlaminate sized to extend slightly beyond the dimension of the printed label
- Excellent abrasion and environmental resistance
- Consult technical data sheet for UL / CSA ratings and complete performance and testing details

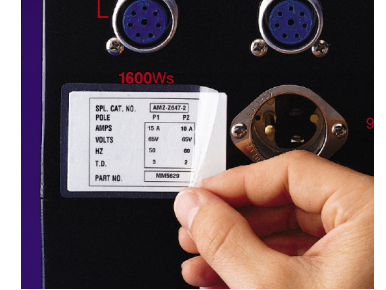
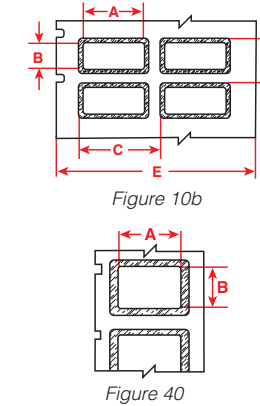

For Use with Printers:	Diagram	Catalog #	Color	Label width A inch (mm)	Label height B inch (mm)	Horiz. repeat C inch (mm)	Vert. repeat D inch (mm)	Web width E inch (mm)	Labels per row	Labels per roll	Rec. ribbon
<b>PermaShield™ Overlaminating Polyester (B-423/B-966B)</b>											
i3300, i5300, BBP33	Fig. 10b	B33-22-423	Gloss White	1.250 (31.8)	0.750 (19.1)	1.650 (41.9)	1.125 (28.5)	3.350 (85.1)	2	2000	B30-R6000
i3300, i5300, BBP33	Fig. 10b	B33-23-423	Gloss White	2.000 (50.8)	1.000 (25.4)	-	1.375 (34.9)	2.450 (62.2)	1	800	B30-R6000
i3300, i5300, BBP33	Fig. 10b	B33-24-423	Gloss White	2.750 (69.9)	1.750 (44.4)	-	2.125 (53.9)	3.200 (81.3)	1	500	B30-R6000
<b>PermaShield™ Overlaminating Metallized Polyester (B-428/B-966B)</b>											
i3300, i5300, BBP33	Fig. 40	B33-22-428	Matte Lt. Gray	1.250 (31.8)	0.750 (19.1)	1.650 (41.9)	1.125 (28.5)	3.350 (85.1)	2	1700	B30-R4300
i3300, i5300, BBP33	Fig. 40	B33-23-428	Matte Lt. Gray	2.000 (50.8)	1.000 (25.4)	-	1.375 (34.9)	2.450 (62.2)	1	700	B30-R4300
i3300, i5300, BBP33	Fig. 40	B33-24-428	Matte Lt. Gray	2.750 (69.9)	1.750 (44.4)	-	2.125 (53.9)	3.200 (81.3)	1	450	B30-R4300

### Aggressive Adhesive General Purpose Vinyl Die-Cut Labels (B-439)

- Indoor and outdoor grade vinyl with high-tack permanent adhesive
- Extremely pliable and highly conforming to rough and irregular surfaces with good chemical and abrasion resistance
- Ideal for general purpose warehouse and industrial labeling when label size consistency and a die-cut put-up is desired
- Not UL / CSA rated
- Consult technical data sheet for complete performance and testing details

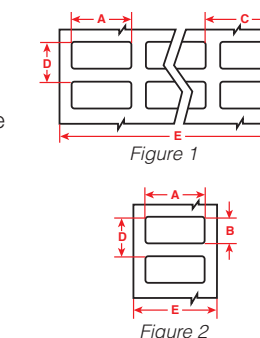

For Use with Printers:	Diagram	Catalog #	Color	Label width A inch (mm)	Label height B inch (mm)	Horiz. repeat C inch (mm)	Vert. repeat D inch (mm)	Web width E inch (mm)	Labels per row	Labels per roll	Rec. ribbon
i3300, i5300, BBP33	Fig. 1	B33-5-439	White	1.000 (25.4)	0.500 (12.7)	1.075 (27.3)	0.600 (15.2)	3.350 (85.1)	3	7000	B30-R6000
i3300, i5300, BBP33	Fig. 1	B33-6-439	White	1.500 (38.1)	0.500 (12.7)	1.650 (41.9)	0.600 (15.2)	3.350 (85.1)	2	5000	B30-R6000
i3300, i5300, BBP33	Fig. 2	B33-53-439	White	2.000 (50.8)	0.500 (12.7)	-	0.600 (15.2)	2.200 (55.9)	1	2500	B30-R6000
i3300, i5300, BBP33	Fig. 2	B33-17-439	White	2.000 (50.8)	1.000 (25.4)	-	1.125 (28.5)	2.200 (55.9)	1	1000	B30-R6000
i3300, i5300, BBP33	Fig. 2	B33-18-439	White	3.000 (76.2)	1.000 (25.4)	-	1.125 (28.5)	3.350 (85.1)	1	1000	B30-R6000
i3300, i5300, BBP33	Fig. 2	B33-19-439	White	3.000 (76.2)	2.000 (50.8)	-	2.125 (53.9)	3.200 (81.3)	1	700	B30-R6000
i3300, i5300, BBP33	Fig. 2	B33-55-439	White	4.000 (101.6)	2.000 (50.8)	-	2.125 (53.9)	4.200 (106.7)	1	700	B30-R6000
i3300, i5300, BBP33	Fig. 2	B33-76-439	White	4.000 (101.6)	3.000 (76.2)	-	3.125 (79.3)	4.200 (106.7)	1	500	B30-R6000

## Paper Labels (B-424)

- Economical choice for light duty part labeling, box labels and general identification
- Bright white finish with excellent image contrast and smear resistance for barcode printing

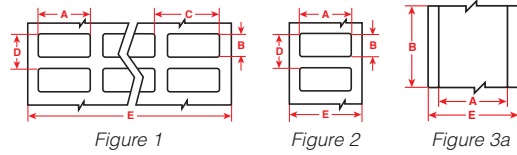

For Use with Printers:	Diagram	Catalog #	Color	Label width A inch (mm)	Label height B inch (mm)	Horiz. repeat C inch (mm)	Vert. repeat D inch (mm)	Web width E inch (mm)	Labels per row	Labels per roll	Rec. ribbon
i3300, i5300, BBP33	Fig. 1	B33-5-424	White	1.000 (25.4)	0.500 (12.7)	1.075 (27.3)	0.600 (15.2)	3.350 (85.0)	3	9000	B30-R4300
i3300, i5300, BBP33	Fig. 1	B33-37-424	White	1.500 (38.1)	0.500 (12.7)	1.650 (41.9)	0.600 (15.2)	3.350 (85.1)	2	6000	B30-R4300
i3300, i5300, BBP33	Fig. 1	B33-6-424	White	1.500 (38.1)	0.750 (19.1)	1.650 (41.9)	0.875 (22.2)	3.350 (85.1)	2	4000	B30-R4300
i3300, i5300, BBP33	Fig. 2	B33-53-424	White	2.000 (50.8)	0.500 (12.7)	–	0.600 (15.2)	2.200 (55.9)	1	2500	B30-R4300
i3300, i5300, BBP33	Fig. 2	B33-17-424	White	2.000 (50.8)	1.000 (25.4)	1.125 (28.6)	2.200 (55.9)	–	1	1500	B30-R4300
i3300, i5300, BBP33	Fig. 2	B33-7-424	White	2.750 (69.9)	1.250 (31.8)	–	1.375 (34.9)	2.950 (74.9)	1	1000	B30-R4300
i3300, i5300, BBP33	Fig. 2	B33-18-424	White	3.000 (76.2)	1.000 (25.4)	1.125 (28.6)	3.200 (81.3)	–	1	1500	B30-R4300
i3300, i5300, S3000, S3100, BBP30, BBP31, BBP33, BBP35, BBP37	Fig. 3a	B30C-3000-424	White	3.000 (76.2)	150 ft. (45.8m)	–	–	3.250 (82.6)	1 roll (cont.)	–	B30-R4300
i3300, i5300, BBP33	Fig. 2	B33-19-424	White	3.000 (76.2)	2.000 (50.8)	2.125 (54.0)	3.200 (81.3)	–	1	500	B30-R4300
i3300, i5300, BBP33	Fig. 2	B33-20-424	White	3.000 (76.2)	5.000 (127)	–	5.125 (130.2)	3.200 (81.3)	1	250	B30-R4300
i3300, i5300, S3000, S3100, BBP30, BBP31, BBP33, BBP35, BBP37	Fig. 3a	B30C-4000-424	White	4.000 (101.6)	150 ft. (45.8 m)	–	–	4.200 (106.7)	1 roll (cont.)	–	B30-R4300
i3300, i5300, BBP33	Fig. 2	B33-55-424	White	4.000 (101.6)	2.000 (50.8)	–	2.125 (54.0)	4.200 (106.7)	1	750	B30-R4300
i3300, i5300, BBP33	Fig. 2	B33-25-424	White	4.000 (101.6)	6.000 (152.4)	6.125 (155.6)	4.200 (106.7)	–	1	350	B30-R4300

## Direct Thermal Paper Labels (B-813, B-816)

- Economical choice for light-duty printing with added benefit of ribbonless printing
- Standard matte white finish
- Permanent and removable adhesive choices
- **Compatible with i5300 printer ONLY**

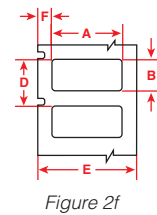

For Use with Printers:	Diagram	Catalog #	Color	Label width A inch (mm)	Label height B inch (mm)	Horiz. repeat C inch (mm)	Vert. repeat D inch (mm)	Web width E inch (mm)	Datum Edge F inch (mm)	Labels per row	Labels per roll
<b>Matte white direct thermal paper (B-813)</b>											
i5300	Fig. 2f	B33-330-813	Matte White	3.000 (76.2)	1.000 (25.4)	–	1.125 (28.6)	4.250 (108.0)	0.625 (15.9)	1	1450
i5300	Fig. 2f	B33-332-813	Matte White	3.000 (76.2)	2.000 (50.8)	–	2.125 (54.0)	4.250 (108.0)	0.625 (15.9)	1	775
i5300	Fig. 2f	B33-331-813	Matte White	3.000 (76.2)	5.000 (127.0)	–	5.125 (103.2)	4.250 (108.0)	0.625 (15.9)	1	325
i5300	Fig. 2f	B33-334-813	Matte White	4.000 (101.6)	2.000 (50.8)	–	2.125 (54.0)	4.250 (108.0)	0.125 (3.2)	1	775
i5300	Fig. 2f	B33-333-813	Matte White	4.000 (101.6)	6.000 (152.4)	–	6.125 (155.6)	4.250 (108.0)	0.125 (3.2)	1	270
<b>Matte white direct thermal paper with removable adhesive (B-816)</b>											
i5300	Fig. 2f	B33-330-816	Matte White	3.000 (76.2)	1.000 (25.4)	–	1.125 (28.6)	4.250 (108.0)	0.625 (15.9)	1	1450
i5300	Fig. 2f	B33-332-816	Matte White	3.000 (76.2)	2.000 (50.8)	–	2.125 (54.0)	4.250 (108.0)	0.625 (15.9)	1	775
i5300	Fig. 2f	B33-331-816	Matte White	3.000 (76.2)	5.000 (127.0)	–	5.125 (103.2)	4.250 (108.0)	0.625 (15.9)	1	325
i5300	Fig. 2f	B33-334-816	Matte White	4.000 (101.6)	2.000 (50.8)	–	2.125 (54.0)	4.250 (108.0)	0.125 (3.2)	1	775
i5300	Fig. 2f	B33-333-816	Matte White	4.000 (101.6)	6.000 (152.4)	–	6.125 (155.6)	4.250 (108.0)	0.125 (3.2)	1	270

## High-Temp Polyimide Labels (B-727, B-728, B-729)

- For pre-process circuit board identification
- Designed to withstand processes, fluxes and solvents used in circuit board manufacturing
- Consult technical data sheet for detailed performance, compliance and ribbon usage information
- **0.20" dimension parts for use in i5300 only**

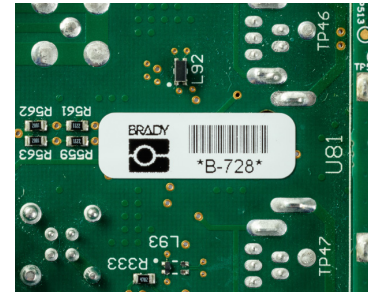
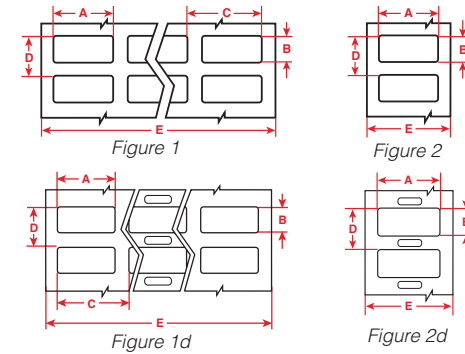

For Use with Printers:	Diagram	Catalog #	Color	Label width A inch (mm)	Label height B inch (mm)	Horiz. repeat C inch (mm)	Vert. repeat D inch (mm)	Web width E inch (mm)	Labels per row	Labels per roll	Rec. ribbon
<b>High-temp gloss polyimide (B-727)</b>											
i3300, i5300, BBP33	Fig. 1	B33-70-727	Gloss White	0.250 (6.4)	0.250 (6.4)	0.320 (8.1)	0.350 (8.9)	2.370 (60.1)	7	20000	B30-R6000
i3300, i5300, BBP33	Fig. 4 (pg.35)	B33-11-727	Gloss White	0.250 (6.35)	0.250 (6.4)	0.250 (6.4)	0.375 (9.5)	3.200 (81.3)	12	5000	B30-R6000
i3300, i5300, BBP33	Fig. 1	B33-71-727	Gloss White	0.315 (8.0)	0.315 (8.0)	0.375 (9.5)	0.450 (11.4)	2.390 (60.7)	6	20000	B30-R6000
i3300, i5300, BBP33	Fig. 1	B33-340-727	Gloss White	0.375 (9.5)	0.375 (9.5)	0.438 (11.1)	0.475 (12.1)	3.500 (88.9)	7	10000	B30-R6000
i3300, i5300, BBP33	Fig. 1	B33-12-727	Gloss White	0.500 (12.7)	0.437 (11.0)	0.662 (16.8)	0.537 (13.6)	3.350 (85.1)	5	10000	B30-R6000
i3300, i5300, BBP33	Fig. 1	B33-149-727	Gloss White	0.500 (12.7)	0.500 (12.7)	0.600 (15.2)	0.600 (15.2)	2.500 (63.5)	4	5000	B30-R6000
i5300	Fig. 2d	B33-342-727	Gloss White	0.650 (16.5)	0.200 (5.0)	–	0.325 (8.2)	0.850 (21.5)	1	3700	B30-R6000
i5300	Fig. 1d	B33-341-727	Gloss White	0.650 (16.5)	0.200 (5.0)	0.700 (17.7)	0.325 (8.2)	2.950 (74.9)	4	10000	B30-R6000
i3300, i5300, BBP33	Fig. 1	B33-1-727	Gloss White	0.750 (19.1)	0.250 (6.4)	0.800 (20.3)	0.350 (8.9)	3.350 (85.1)	4	5000	B30-R6000
i3300, i5300, BBP33	Fig. 2	B33-49-727	Gloss White	0.900 (22.9)	0.250 (6.4)	–	0.350 (8.9)	1.100 (27.9)	1	5000	B30-R6000
i3300, i5300, BBP33	Fig. 1	B33-2-727	Gloss White	0.900 (22.9)	0.250 (6.4)	1.125 (28.6)	0.350 (8.9)	3.350 (85.1)	3	5000	B30-R6000
i3300, i5300, BBP33	Fig. 1	B33-51-727	Gloss White	1.000 (25.4)	0.250 (6.4)	1.075 (27.3)	0.350 (8.9)	3.350 (85.1)	3	10000	B30-R6000
i3300, i5300, BBP33	Fig. 2	B33-103-727	Gloss White	1.000 (25.4)	0.250 (6.4)	–	0.350 (8.9)	1.200 (30.5)	1	5000	B30-R6000
i3300, i5300, BBP33	Fig. 2	B33-58-727	Gloss White	1.000 (25.4)	0.375 (9.5)	–	0.475 (12.1)	1.200 (30.5)	1	4000	B30-R6000
i3300, i5300, BBP33	Fig. 1	B33-3-727	Gloss White	1.000 (25.4)	0.375 (9.5)	1.075 (27.3)	0.475 (12.1)	3.350 (85.1)	3	10000	B30-R6000
i3300, i5300, BBP33	Fig. 2	B33-59-727	Gloss White	1.000 (25.4)	0.500 (12.7)	–	0.600 (15.2)	1.200 (30.5)	1	2500	B30-R6000
i3300, i5300, BBP33	Fig. 1	B33-5-727	Gloss White	1.000 (25.4)	0.500 (12.7)	1.075 (27.3)	0.600 (15.2)	3.350 (85.1)	3	7000	B30-R6000
i3300, i5300, BBP33	Fig. 1	B33-13-727	Gloss White	1.250 (31.8)	0.250 (6.4)	1.300 (33.0)	0.375 (9.5)	2.750 (69.9)	2	5000	B30-R6000
i3300, i5300, BBP33	Fig. 2	B33-43-727	Gloss White	1.250 (31.8)	0.250 (6.4)	–	0.350 (8.9)	1.450 (36.8)	1	5000	B30-R6000
i3300, i5300, BBP33	Fig. 2	B33-44-727	Gloss White	1.375 (34.9)	0.250 (6.4)	–	0.350 (8.9)	1.600 (40.6)	1	5000	B30-R6000
i3300, i5300, BBP33	Fig. 1	B33-4-727	Gloss White	1.500 (38.1)	0.250 (6.4)	1.650 (41.9)	0.350 (8.9)	3.350 (85.1)	2	10000	B30-R6000
i3300, i5300, BBP33	Fig. 2	B33-45-727	Gloss White	1.500 (38.1)	0.250 (6.4)	–	0.350 (8.9)	1.700 (43.2)	1	5000	B30-R6000
i3300, i5300, BBP33	Fig. 2	B33-72-727	Gloss White	1.750 (44.5)	0.250 (6.4)	–	0.350 (8.9)	1.950 (49.5)	1	5000	B30-R6000
i3300, i5300, BBP33	Fig. 2	B33-15-727	Gloss White	2.000 (50.8)	0.250 (6.4)	–	0.375 (9.5)	2.200 (55.9)	1	3200	B30-R6000
i3300, i5300, S3000, S3100, BBP30, BBP31, BBP33, BBP35, BBP37	Fig. 3	B30C-4000-727	Gloss White	4.000 (101.6)	100 ft. (30.5 m)	–	–	4.200 (106.7)	1 roll (cont.)	–	B30-R6000
<b>High-temp matte polyimide for solder ball reduction (B-728)</b>											
i3300, i5300, BBP33	Fig. 1	B33-70-728	Matte White	0.250 (6.4)	0.250 (6.4)	0.320 (8.1)	0.350 (8.9)	2.370 (60.1)	7	20000	B30-R6000
i3300, i5300, BBP33	Fig. 1	B33-340-728	Matte White	0.375 (9.5)	0.375 (9.5)	0.438 (11.1)	0.475 (12.1)	3.500 (88.9)	7	10000	B30-R6000
i3300, i5300, BBP33	Fig. 1	B33-12-728	Matte White	0.500 (12.7)	0.437 (11.0)	0.662 (16.8)	0.537 (13.6)	3.350 (85.1)	5	10000	B30-R6000
i5300	Fig. 1d	B33-341-728	Matte White	0.650 (16.5)	0.200 (5.0)	0.700 (17.7)	0.325 (8.2)	2.950 (74.9)	4	10000	B30-R6000
i3300, i5300, BBP33	Fig. 1	B33-1-728	Matte White	0.750 (19.1)	0.250 (6.4)	0.800 (20.3)	0.350 (8.9)	3.350 (85.1)	4	10000	B30-R6000
i3300, i5300, BBP33	Fig. 1	B33-2-728	Matte White	0.900 (22.9)	0.250 (6.4)	1.125 (28.5)	0.350 (8.9)	3.350 (85.1)	3	10000	B30-R6000
i3300, i5300, BBP33	Fig. 1	B33-51-728	Matte White	1.000 (25.4)	0.250 (6.4)	1.075 (27.3)	0.350 (8.9)	3.350 (85.1)	3	10000	B30-R6000
i3300, i5300, BBP33	Fig. 2	B33-103-728	Matte White	1.000 (25.4)	0.250 (6.4)	–	0.350 (8.9)	1.200 (30.4)	1	4000	B30-R6000
i3300, i5300, BBP33	Fig. 1	B33-5-728	Matte White	1.000 (25.4)	0.500 (12.7)	1.075 (27.3)	0.600 (15.2)	3.350 (85.1)	3	7000	B30-R6000
i3300, i5300, BBP33	Fig. 1	B33-13-728	Matte White	1.250 (31.8)	0.250 (6.4)	1.300 (33.0)	0.375 (9.5)	2.750 (69.9)	2	7000	B30-R6000
i3300, i5300, BBP33	Fig. 2	B33-43-728	Matte White	1.250 (31.8)	0.250 (6.4)	–	0.350 (8.9)	1.450 (36.8)	1	4000	B30-R6000
i3300, i5300, BBP33	Fig. 1	B33-4-728	Matte White	1.500 (38.1)	0.250 (6.4)	1.650 (41.9)	0.350 (8.9)	3.350 (85.1)	2	8000	B30-R6000
<b>Ultra-thin high-temp matte polyimide for solderball reduction (B-729)</b>											
i3300, i5300, BBP33	Fig. 1	B33-70-729	Matte White	0.250 (6.4)	0.250 (6.4)	0.320 (8.1)	0.350 (8.9)	2.370 (60.1)	7	20000	B30-R6000
i3300, i5300, BBP33	Fig. 1	B33-340-729	Matte White	0.375 (9.5)	0.375 (9.5)	0.438 (11.1)	0.475 (12.1)	3.500 (88.9)	7	10000	B30-R6000
i3300, i5300, BBP33	Fig. 1	B33-12-729	Matte White	0.500 (12.7)	0.437 (11.0)	0.662 (16.8)	0.537 (13.6)	3.350 (85.1)	5	10000	B30-R6000
i5300	Fig. 1d	B33-341-729	Matte White	0.650 (16.5)	0.200 (5.0)	0.700 (17.7)	0.325 (8.2)	2.950 (74.9)	4	10000	B30-R6000
i3300, i5300, BBP33	Fig. 1	B33-1-729	Matte White	0.750 (19.1)	0.250 (6.4)	0.800 (20.3)	0				

## High-Temp Electrostatic Dissipative Polyimide Labels (B-717, B-718, B-719)

- For pre-process circuit board identification where static dissipative properties are required
- Materials feature both a permanent static dissipative adhesive and static dissipative release liner
- Designed to withstand processes, fluxes and solvents used in circuit board manufacturing
- UL969 rated, consult technical data sheet for complete performance and ribbon usage criteria
- **0.20" dimension parts for use in i5300 only**

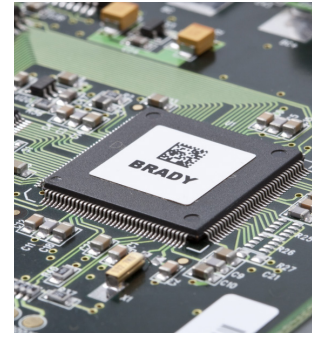
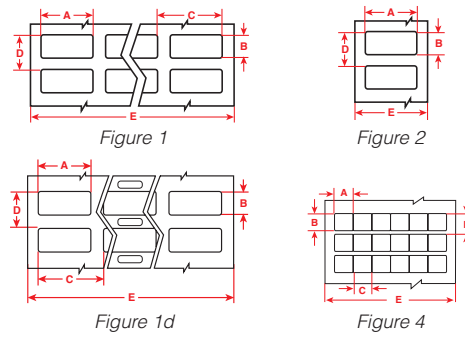

For Use with Printers:	Diagram	Catalog #	Color	Label width A inch (mm)	Label height B inch (mm)	Horiz. repeat C inch (mm)	Vert. repeat D inch (mm)	Web width E inch (mm)	Labels per row	Labels per roll	Rec. ribbon
<b>Electrostatic dissipative gloss polyimide (B-717)</b>											
i3300, i5300, BBP33	Fig. 1	B33-70-717	Gloss White	0.250 (6.4)	0.250 (6.4)	0.320 (8.1)	0.350 (8.9)	2.370 (60.1)	7	20000	B30-R6000
i3300, i5300, BBP33	Fig. 1	B33-340-717	Gloss White	0.375 (9.5)	0.375 (9.5)	0.438 (11.1)	0.475 (12.1)	3.500 (88.9)	7	10000	B30-R6000
i3300, i5300, BBP33	Fig. 1	B33-12-717	Gloss White	0.500 (12.7)	0.437 (11.0)	0.662 (16.8)	0.537 (13.6)	3.350 (85.1)	5	10000	B30-R6000
i5300	Fig. 1d	B33-341-717	Gloss White	0.650 (16.5)	0.200 (5.0)	0.700 (17.7)	0.325 (8.2)	2.950 (74.9)	4	10000	B30-R6000
i3300, i5300, BBP33	Fig. 1	B33-1-717	Gloss White	0.750 (19.1)	0.250 (6.4)	0.800 (20.3)	0.350 (8.9)	3.350 (85.1)	4	10000	B30-R6000
i3300, i5300, BBP33	Fig. 2	B33-46-717	Gloss White	0.750 (19.1)	0.250 (6.4)	–	0.350 (8.9)	0.950 (24.1)	1	5000	B30-R6000
i3300, i5300, BBP33	Fig. 1	B33-2-717	Gloss White	0.900 (22.9)	0.250 (6.4)	1.125 (28.5)	0.350 (8.9)	3.350 (85.1)	3	10000	B30-R6000
i3300, i5300, BBP33	Fig. 1	B33-51-717	Gloss White	1.000 (25.4)	0.250 (6.4)	1.075 (27.3)	0.350 (8.9)	3.350 (85.1)	3	10000	B30-R6000
i3300, i5300, BBP33	Fig. 2	B33-103-717	Gloss White	1.000 (25.4)	0.250 (6.4)	–	0.350 (8.9)	1.200 (30.5)	1	5000	B30-R6000
i3300, i5300, BBP33	Fig. 1	B33-5-717	Gloss White	1.000 (25.4)	0.500 (12.7)	1.075 (27.3)	0.600 (15.2)	3.350 (85.1)	3	7000	B30-R6000
i3300, i5300, BBP33	Fig. 1	B33-13-717	Gloss White	1.250 (31.8)	0.250 (6.4)	1.300 (33.0)	0.375 (9.5)	2.750 (69.9)	2	7000	B30-R6000
i3300, i5300, BBP33	Fig. 2	B33-43-717	Gloss White	1.250 (31.8)	0.250 (6.4)	–	0.350 (8.9)	1.450 (36.8)	1	5000	B30-R6000
i3300, i5300, BBP33	Fig. 1	B33-4-717	Gloss White	1.500 (38.1)	0.250 (6.4)	1.650 (41.9)	0.350 (8.9)	3.350 (85.1)	2	8000	B30-R6000
i3300, i5300, BBP33	Fig. 2	B33-45-717	Gloss White	1.500 (38.1)	0.250 (6.4)	–	0.350 (8.9)	1.700 (43.2)	1	5000	B30-R6000
<b>Ultra-thin electrostatic dissipative gloss polyimide (B-718)</b>											
i3300, i5300, BBP33	Fig. 4	B33-11-718	Gloss White	0.250 (6.4)	0.250 (6.4)	0.250 (6.4)	0.375 (9.5)	3.200 (81.3)	12	1500	B30-R6000
i3300, i5300, BBP33	Fig. 1	B33-340-718	Gloss White	0.375 (9.5)	0.375 (9.5)	0.438 (11.1)	0.475 (12.1)	3.500 (88.9)	7	10000	B30-R6000
i3300, i5300, BBP33	Fig. 1	B33-12-718	Gloss White	0.500 (12.7)	0.437 (11.0)	0.662 (16.8)	0.537 (13.6)	3.350 (85.1)	5	10000	B30-R6000
i3300, i5300, BBP33	Fig. 1	B33-149-718	Gloss White	0.500 (12.7)	0.500 (12.7)	0.600 (15.2)	0.600 (15.2)	2.500 (63.5)	4	5000	B30-R6000
i5300	Fig. 1d	B33-341-718	Gloss White	0.650 (16.5)	0.200 (5.0)	0.700 (17.7)	0.325 (8.2)	2.950 (74.9)	4	10000	B30-R6000
i3300, i5300, BBP33	Fig. 1	B33-1-718	Gloss White	0.750 (19.1)	0.250 (6.4)	0.800 (20.3)	0.350 (8.9)	3.350 (85.1)	4	5000	B30-R6000
i3300, i5300, BBP33	Fig. 2	B33-46-718	Gloss White	0.750 (19.1)	0.250 (6.4)	–	0.350 (8.9)	0.950 (24.1)	1	5000	B30-R6000
i3300, i5300, BBP33	Fig. 1	B33-2-718	Gloss White	0.900 (22.9)	0.250 (6.4)	1.125 (28.5)	0.350 (8.9)	3.350 (85.1)	3	10000	B30-R6000
i3300, i5300, BBP33	Fig. 2	B33-49-718	Gloss White	0.900 (22.9)	0.250 (6.4)	–	0.350 (8.9)	1.100 (27.9)	1	5000	B30-R6000
i3300, i5300, BBP33	Fig. 1	B33-51-718	Gloss White	1.000 (25.4)	0.250 (6.4)	1.075 (27.3)	0.350 (8.9)	3.350 (85.1)	3	10000	B30-R6000
i3300, i5300, BBP33	Fig. 2	B33-103-718	Gloss White	1.000 (25.4)	0.250 (6.4)	–	0.350 (8.9)	1.200 (30.4)	1	4000	B30-R6000
i3300, i5300, BBP33	Fig. 1	B33-3-718	Gloss White	1.000 (25.4)	0.375 (9.5)	1.075 (27.3)	0.475 (12.1)	3.350 (85.1)	3	10000	B30-R6000
i3300, i5300, BBP33	Fig. 1	B33-5-718	Gloss White	1.000 (25.4)	0.500 (12.7)	1.075 (27.3)	0.600 (15.2)	3.350 (85.1)	3	10000	B30-R6000
i3300, i5300, BBP33	Fig. 1	B33-13-718	Gloss White	1.250 (31.8)	0.250 (6.4)	1.300 (33.0)	0.375 (9.5)	2.750 (69.9)	2	7000	B30-R6000
i3300, i5300, BBP33	Fig. 2	B33-43-718	Gloss White	1.250 (31.8)	0.250 (6.4)	–	0.350 (8.9)	1.450 (36.8)	1	5000	B30-R6000
i3300, i5300, BBP33	Fig. 1	B33-4-718	Gloss White	1.500 (38.1)	0.250 (6.4)	1.650 (41.9)	0.350 (8.9)	3.350 (85.1)	2	8000	B30-R6000
i3300, i5300, BBP33	Fig. 2	B33-45-718	Gloss White	1.500 (38.1)	0.250 (6.4)	–	0.350 (8.9)	1.700 (43.2)	1	5000	B30-R6000
i3300, i5300, BBP33	Fig. 2	B33-72-718	Gloss White	1.750 (44.5)	0.250 (6.4)	–	0.350 (8.9)	1.950 (49.5)	1	5000	B30-R6000
i3300, i5300, BBP33	Fig. 2	B33-15-718	Gloss White	2.000 (50.8)	0.250 (6.4)	–	0.375 (9.5)	2.200 (55.9)	1	3200	B30-R6000
<b>Ultra-thin electrostatic dissipative matte polyimide for solderball reduction (B-719)</b>											
i3300, i5300, BBP33	Fig. 1	B33-70-719	Matte White	0.250 (6.4)	0.250 (6.4)	0.320 (8.1)	0.350 (8.9)	2.370 (60.1)	7	20000	B30-R6000
i3300, i5300, BBP33	Fig. 1	B33-340-719	Matte White	0.375 (9.5)	0.375 (9.5)	0.438 (11.1)	0.475 (12.1)	3.500 (88.9)	7	10000	B30-R6000
i3300, i5300, BBP33	Fig. 1	B33-12-719	Matte White	0.500 (12.7)	0.437 (11.0)	0.662 (16.8)	0.537 (13.6)	3.350 (85.1)	5	10000	B30-R6000
i5300	Fig. 1d	B33-341-719	Matte White	0.650 (16.5)	0.200 (5.0)	0.700 (17.7)	0.325 (8.2)	2.950 (74.9)	4	10000	B30-R6000
i3300, i5300, BBP33	Fig. 1	B33-1-719	Matte White	0.750 (19.1)	0.250 (6.4)	0.800 (20.3)	0.350 (8.9)	3.350 (85.1)	4	10000	B30-R6000
i3300, i5300, BBP33	Fig. 2	B33-46-719	Matte White	0.750 (19.1)	0.250 (6.4)	–	0.350 (8.9)	0.950 (24.1)	1	5000	B30-R6000
i3300, i5300, BBP33	Fig. 1	B33-2-719	Matte White	0.900 (22.9)	0.250 (6.4)	1.125 (28.6)	0.350 (8.9)	3.350 (85.1)	3	5000	B30-R6000
i3300, i5300, BBP33	Fig. 1	B33-51-719	Matte White	1.000 (25.4)	0.250 (6.4)	1.075 (27.3)	0.350 (8.9)	3.350 (85.1)	3	10000	B30-R6000
i3300, i5300, BBP33	Fig. 2	B33-103-719	Matte White	1.000 (25.4)	0.250 (6.4)	–	0.350 (8.9)	1.200 (30.4)	1	4000	B30-R6000
i3300, i5300, BBP33	Fig. 1	B33-5-719	Matte White	1.000 (25.4)	0.500 (12.7)	1.075 (27.3)	0.600 (15.2)	3.350 (85.1)	3	7000	B30-R6000
i3300, i5300, BBP33	Fig. 1	B33-13-719	Matte White	1.250 (31.8)	0.250 (6.4)	1.300 (33.0)	0.375 (9.5)	2.750 (69.9)	2	7000	B30-R6000
i3300, i5300, BBP33	Fig. 2	B33-43-719	Matte White	1.250 (31.8)	0.250 (6.4)	–	0.350 (8.9)	1.450 (36.8)	1	5000	B30-R6000
i3300, i5300, BBP33	Fig. 1	B33-4-719	Matte White	1.500 (38.1)	0.250 (6.4)	1.650 (41.9)	0.350 (8.9)	3.350 (85.1)	2	8000	B30-R6000
i3300, i5300, BBP33	Fig. 1	B33-13-729	Matte White	1.250 (31.8)	0.250 (6.4)	1.300 (33.0)	0.375 (9.5)	2.750 (69.9)	2	7000	B30-R6000
i3300, i5300, BBP33	Fig. 2	B33-43-729	Matte White	1.250 (31.8)	0.250 (6.4)	–	0.350 (8.9)	1.450 (36.8)	1	4000	B30-R6000
i3300, i5300, BBP33	Fig. 1	B33-4-729	Matte White	1.500 (38.1)	0.250 (6.4)	1.650 (41.9)	0.350 (8.9)	3.350 (85.1)	2	8000	B30-R6000

## Ultra High-Temp Matte Amber Polyimide Labels (B-724)

- For pre-process circuit board identification
- Extremely high temperature resistance for top or bottom-side board and component ID
- Designed to withstand processes, fluxes and solvents used in circuit board manufacturing
- Consult technical data sheet for complete performance and ribbon usage criteria
- **0.20" dimension parts for use in i5300 only**

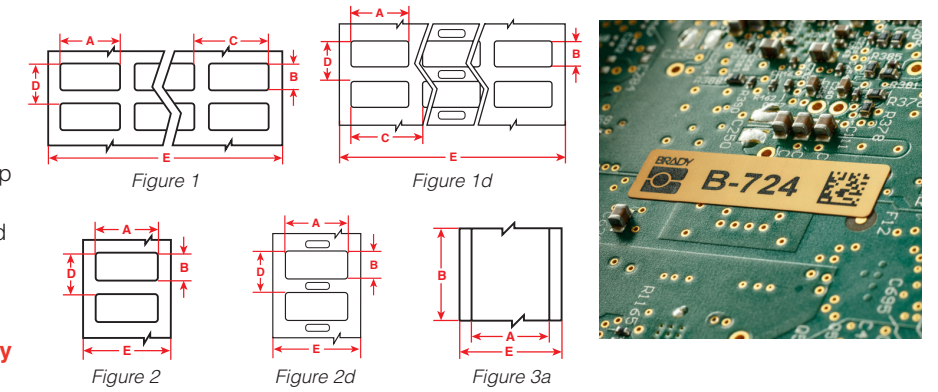

For Use with Printers:	Diagram	Catalog #	Color	Label width A inch (mm)	Label height B inch (mm)	Horiz. repeat C inch (mm)	Vert. repeat D inch (mm)	Web width E inch (mm)	Labels per row	Labels per roll	Rec. ribbon
i3300, i5300, BBP33	Fig. 1	B33-340-724	Matte Amber	0.375 (9.5)	0.375 (9.5)	0.438 (11.1)	0.475 (12.1)	3.500 (88.9)	7	10000	B30-R4300
i5300	Fig. 2d	B33-344-724	Matte Amber	0.500 (0.0)	0.200 (0.0)	–	0.325 (8.2)	0.850 (21.6)	1	3700	B30-R4300
i3300, i5300, BBP33	Fig. 1	B33-12-724	Matte Amber	0.500 (12.7)	0.437 (11.0)	0.662 (16.8)	0.537 (13.6)	3.350 (85.1)	5	10000	B30-R4300
i3300, i5300, BBP33	Fig. 1	B33-149-724	Matte Amber	0.500 (12.7)	0.500 (12.7)	0.600 (15.2)	0.600 (15.2)	2.500 (63.5)	4	5000	B30-R4300
i5300	Fig. 2d	B33-342-724	Matte Amber	0.650 (0.0)	0.200 (0.0)	–	0.325 (8.2)	0.850 (21.5)	1	3700	B30-R4300
i5300	Fig. 1d	B33-341-724	Matte Amber	0.650 (16.5)	0.200 (5.0)	0.700 (17.7)	0.325 (8.2)	2.950 (74.9)	4	10000	B30-R4300
i3300, i5300, BBP33	Fig. 2	B33-46-724	Matte Amber	0.750 (19.1)	0.250 (6.4)	–	0.350 (8.9)	0.950 (24.1)	1	5000	B30-R4300
i3300, i5300, BBP33	Fig. 1	B33-1-724	Matte Amber	0.750 (19.1)	0.250 (6.4)	0.800 (20.3)	0.350 (8.9)	3.350 (85.1)	4	5000	B30-R4300
i3300, i5300, BBP33	Fig. 1	B33-2-724	Matte Amber	0.900 (22.9)	0.250 (6.4)	1.125 (28.6)	0.350 (8.9)	3.350 (85.1)	3	5000	B30-R4300
i3300, i5300, BBP33	Fig. 1	B33-51-724	Matte Amber	1.000 (25.4)	0.250 (6.4)	1.075 (27.3)	0.350 (8.9)	3.350 (85.1)	3	10000	B30-R4300
i3300, i5300, BBP33	Fig. 2	B33-103-724	Matte Amber	1.000 (25.4)	0.250 (6.4)	–	0.350 (8.9)	1.200 (30.4)	1	4000	B30-R4300
i3300, i5300, BBP33	Fig. 1	B33-5-724	Matte Amber	1.000 (25.4)	0.500 (12.7)	1.075 (27.3)	0.600 (15.2)	3.350 (85.1)	3	7000	B30-R4300
i3300, i5300, BBP33	Fig. 1	B33-13-724	Matte Amber	1.250 (31.8)	0.250 (6.4)	1.300 (33.0)	0.375 (9.5)	2.750 (69.9)	2	7000	B30-R4300
i3300, i5300, BBP33	Fig. 2	B33-43-724	Matte Amber	1.250 (31.8)	0.250 (6.4)	–	0.350 (8.9)	1.450 (36.8)	1	5000	B30-R4300
i3300, i5300, BBP33	Fig. 1	B33-4-724	Matte Amber	1.500 (38.1)	0.250 (6.4)	–	0.350 (8.9)	3.350 (85.1)	2	5000	B30-R4300
i3300, i5300, S3000, S3100, BBP30, BBP31, BBP33, BBP35, BBP37	Fig. 3a	B30C-4000-724	Matte Amber	4.000 (101.6)	100 ft. (30.5 m)	–	–	4.200 (106.7)	1 roll (cont.)		B30-R4300

## Non-Reflow Non-Preheat High-Temp Polyimide Labels (B-777)

- For pre-process circuit board identification
- Does not require pre-heating for repeat exposure to harsh processes
- Designed to withstand processes, fluxes and solvents used in circuit board manufacturing
- Consult technical data sheet for complete performance and ribbon usage criteria
- **0.20" dimension parts for use in i5300 only**

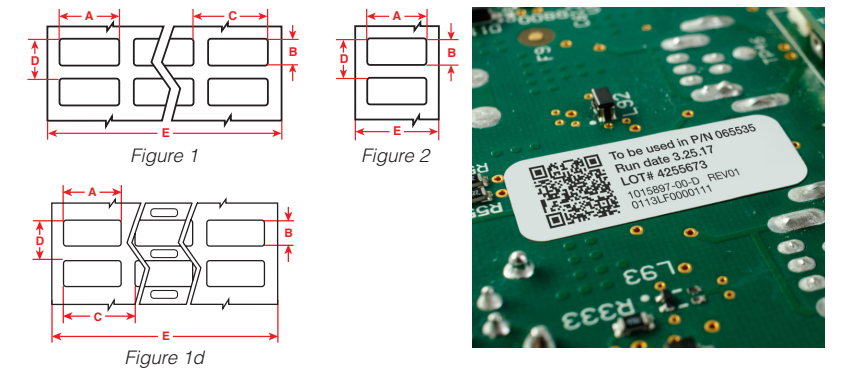

## Raised Profile Labels – Engraved Plate Substitutes – Push Button Style (B-593)

- Costs up to 80% less than engraved legend plates
- High gloss, polyester label with thick raised profile and ultra-aggressive adhesive (0.70 mm thick)
- High-performance, low-cost substitute to engraved plates
- 10-year outdoor durability rating
- 5 push button sizes (including keyed and non-keyed 22.5 mm and 30.5 mm hole dia. keyed)

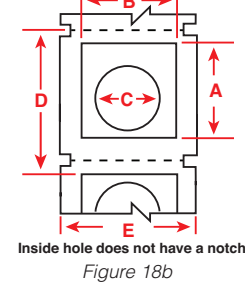
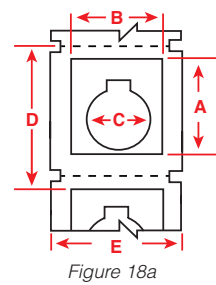

## Raised Profile Labels – Engraved Plate Substitutes – Rectangular Style (B-593)

- Costs up to 80% less than engraved legend plates
- High-gloss, polyester label with thick raised profile and ultra-aggressive adhesive (0.70 mm thick)
- Ideal for front-of-panel identification as well as inside-panel backer board labels and component identification
- Costs up to 80% less than engraved plates and prints out in about 4 seconds
- 10-year outdoor durability rating

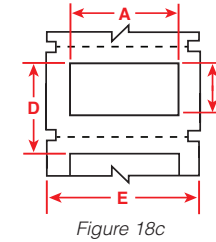

For Use with Printers:	Diagram	Catalog #	Color	Label height A inch (mm)	Label width B inch (mm)	Hole dia. C inch (mm)	Vert. repeat D inch (mm)	Web width E inch (mm)	Labels per row	Labels per roll	Rec. ribbon
i3300, i5300, S3000, S3100, BBP30, BBP31, BBP33, BBP35, BBP37	Fig. 18a	B30EP-167-593-WT	White	1.500 (38.1)	1.200 (30.5)	0.885 (22.5)	1.750 (44.5)	2.500 (63.5)	1	200	B30-R6000
i3300, i5300, S3000, S3100, BBP30, BBP31, BBP33, BBP35, BBP37	Fig. 18b	B30EP-167U-593-WT	White	1.500 (38.1)	1.200 (30.5)	0.885 (22.5)	1.750 (44.5)	2.500 (63.5)	1	200	B30-R6000
i3300, i5300, S3000, S3100, BBP30, BBP31, BBP33, BBP35, BBP37	Fig. 18a	B30EP-169-593-WT	White	1.800 (45.7)	1.800 (45.7)	1.200 (30.5)	2.000 (50.8)	2.500 (63.5)	1	190	B30-R6000
i3300, i5300, S3000, S3100, BBP30, BBP31, BBP33, BBP35, BBP37	Fig. 18a	B30EP-168-593-WT	White	1.900 (48.3)	1.200 (30.5)	0.885 (22.5)	2.125 (54.0)	2.500 (63.5)	1	180	B30-R6000
i3300, i5300, S3000, S3100, BBP30, BBP31, BBP33, BBP35, BBP37	Fig. 18a	B30EP-170-593-WT	White	2.400 (60.9)	2.400 (60.9)	1.200 (30.5)	2.625 (66.7)	3.250 (82.6)	1	145	B30-R6000
i3300, i5300, S3000, S3100, BBP30, BBP31, BBP33, BBP35, BBP37	Fig. 18a	B30EP-167-593-YL	Yellow	1.500 (38.1)	1.200 (30.5)	0.885 (22.5)	1.750 (44.5)	2.500 (63.5)	1	200	B30-R6000
i3300, i5300, S3000, S3100, BBP30, BBP31, BBP33, BBP35, BBP37	Fig. 18b	B30EP-167U-593-YL	Yellow	1.500 (38.1)	1.200 (30.5)	0.885 (22.5)	1.750 (44.5)	2.500 (63.5)	1	200	B30-R6000
i3300, i5300, S3000, S3100, BBP30, BBP31, BBP33, BBP35, BBP37	Fig. 18a	B30EP-169-593-YL	Yellow	1.800 (45.7)	1.800 (45.7)	1.200 (30.5)	2.000 (50.8)	2.500 (63.5)	1	190	B30-R6000
i3300, i5300, S3000, S3100, BBP30, BBP31, BBP33, BBP35, BBP37	Fig. 18a	B30EP-168-593-YL	Yellow	1.900 (48.3)	1.200 (30.5)	0.885 (22.5)	2.125 (54.0)	2.500 (63.5)	1	180	B30-R6000
i3300, i5300, S3000, S3100, BBP30, BBP31, BBP33, BBP35, BBP37	Fig. 18a	B30EP-170-593-YL	Yellow	2.400 (60.9)	2.400 (60.9)	1.200 (30.5)	2.625 (66.7)	3.250 (82.6)	1	145	B30-R6000
i3300, i5300, S3000, S3100, BBP30, BBP31, BBP33, BBP35, BBP37	Fig. 18a	B30EP-167-593-BK	Black	1.500 (38.1)	1.200 (30.5)	0.885 (22.5)	1.750 (44.5)	2.500 (63.5)	1	200	B30-R4400-WT
i3300, i5300, S3000, S3100, BBP30, BBP31, BBP33, BBP35, BBP37	Fig. 18b	B30EP-167U-593-BK	Black	1.500 (38.1)	1.200 (30.5)	0.885 (22.5)	1.750 (44.5)	2.500 (63.5)	1	200	B30-R4400-WT
i3300, i5300, S3000, S3100, BBP30, BBP31, BBP33, BBP35, BBP37	Fig. 18a	B30EP-169-593-BK	Black	1.800 (45.7)	1.800 (45.7)	1.200 (30.5)	2.000 (50.8)	2.500 (63.5)	1	190	B30-R4400-WT
i3300, i5300, S3000, S3100, BBP30, BBP31, BBP33, BBP35, BBP37	Fig. 18a	B30EP-168-593-BK	Black	1.900 (48.3)	1.200 (30.5)	0.885 (22.5)	2.125 (54.0)	2.500 (63.5)	1	180	B30-R4400-WT
i3300, i5300, S3000, S3100, BBP30, BBP31, BBP33, BBP35, BBP37	Fig. 18a	B30EP-170-593-BK	Black	2.400 (60.9)	2.400 (60.9)	1.200 (30.5)	2.625 (66.7)	3.250 (82.6)	1	145	B30-R4400-WT
i3300, i5300, S3000, S3100, BBP30, BBP31, BBP33, BBP35, BBP37	Fig. 18a	B30EP-167-593-GN	Green	1.500 (38.1)	1.200 (30.5)	0.885 (22.5)	1.750 (44.5)	2.500 (63.5)	1	200	B30-R4400-WT
i3300, i5300, S3000, S3100, BBP30, BBP31, BBP33, BBP35, BBP37	Fig. 18b	B30EP-167U-593-GN	Green	1.500 (38.1)	1.200 (30.5)	0.885 (22.5)	1.750 (44.5)	2.500 (63.5)	1	200	B30-R4400-WT
i3300, i5300, S3000, S3100, BBP30, BBP31, BBP33, BBP35, BBP37	Fig. 18a	B30EP-169-593-GN	Green	1.800 (45.7)	1.800 (45.7)	1.200 (30.5)	2.000 (50.8)	2.500 (63.5)	1	190	B30-R4400-WT
i3300, i5300, S3000, S3100, BBP30, BBP31, BBP33, BBP35, BBP37	Fig. 18a	B30EP-168-593-GN	Green	1.900 (48.3)	1.200 (30.5)	0.885 (22.5)	2.125 (54.0)	2.500 (63.5)	1	180	B30-R4400-WT
i3300, i5300, S3000, S3100, BBP30, BBP31, BBP33, BBP35, BBP37	Fig. 18a	B30EP-170-593-GN	Green	2.400 (60.9)	2.400 (60.9)	1.200 (30.5)	2.625 (66.7)	3.250 (82.6)	1	145	B30-R4400-WT
i3300, i5300, S3000, S3100, BBP30, BBP31, BBP33, BBP35, BBP37	Fig. 18a	B30EP-167-593-RD	Red	1.500 (38.1)	1.200 (30.5)	0.885 (22.5)	1.750 (44.5)	2.500 (63.5)	1	200	B30-R4400-WT
i3300, i5300, S3000, S3100, BBP30, BBP31, BBP33, BBP35, BBP37	Fig. 18b	B30EP-167U-593-RD	Red	1.500 (38.1)	1.200 (30.5)	0.885 (22.5)	1.750 (44.5)	2.500 (63.5)	1	200	B30-R4400-WT
i3300, i5300, S3000, S3100, BBP30, BBP31, BBP33, BBP35, BBP37	Fig. 18a	B30EP-169-593-RD	Red	1.800 (45.7)	1.800 (45.7)	1.200 (30.5)	2.000 (50.8)	2.500 (63.5)	1	190	B30-R4400-WT
i3300, i5300, S3000, S3100, BBP30, BBP31, BBP33, BBP35, BBP37	Fig. 18a	B30EP-168-593-RD	Red	1.900 (48.3)	1.200 (30.5)	0.885 (22.5)	2.125 (54.0)	2.500 (63.5)	1	180	B30-R4400-WT
i3300, i5300, S3000, S3100, BBP30, BBP31, BBP33, BBP35, BBP37	Fig. 18a	B30EP-170-593-RD	Red	2.400 (60.9)	2.400 (60.9)	1.200 (30.5)	2.625 (66.7)	3.250 (82.6)	1	145	B30-R4400-WT

For Use with Printers:	Diagram	Catalog #	Color	Label width A inch (mm)	Label height B inch (mm)	Vert. repeat D inch (mm)	Web width E inch (mm)	Labels per row	Labels per roll	Rec. ribbon
i3300, i5300, S3000, S3100, BBP30, BBP31, BBP33, BBP35, BBP37	Fig. 18c	B30EP-171-593-WT	White	1.060 (26.9)	0.490 (12.5)	0.750 (19.1)	1.375 (34.9)	1	500	B30-R6000
i3300, i5300, S3000, S3100, BBP30, BBP31, BBP33, BBP35, BBP37	Fig. 18c	B30EP-172-593-WT	White	1.770 (45.0)	0.590 (15.0)	0.850 (21.6)	2.500 (63.5)	1	450	B30-R6000
i3300, i5300, S3000, S3100, BBP30, BBP31, BBP33, BBP35, BBP37	Fig. 18c	B30EP-175-593-WT	White	3.000 (76.2)	0.750 (19.1)	1.000 (25.4)	3.250 (82.6)	1	375	B30-R6000
i3300, i5300, S3000, S3100, BBP30, BBP31, BBP33, BBP35, BBP37	Fig. 18c	B30EP-173-593-WT	White	2.000 (50.8)	1.000 (25.4)	1.250 (31.8)	2.500 (63.5)	1	300	B30-R6000
i3300, i5300, S3000, S3100, BBP30, BBP31, BBP33, BBP35, BBP37	Fig. 18c	B30EP-174-593-WT	White	4.000 (101.6)	1.000 (25.4)	1.250 (31.8)	4.250 (108.0)	1	300	B30-R6000
i3300, i5300, S3000, S3100, BBP30, BBP31, BBP33, BBP35, BBP37	Fig. 18c	B30EP-176-593-WT	White	3.000 (76.2)	1.000 (25.4)	1.250 (31.8)	3.250 (82.6)	1	300	B30-R6000
i3300, i5300, S3000, S3100, BBP30, BBP31, BBP33, BBP35, BBP37	Fig. 18c	B30EP-177-593-WT	White	3.000 (76.2)	2.500 (63.5)	2.750 (69.9)	3.250 (82.6)	1	125	B30-R6000
i3300, i5300, S3000, S3100, BBP30, BBP31, BBP33, BBP35, BBP37	Fig. 18c	B30EP-171-593-YL	Yellow	1.060 (26.9)	0.490 (12.5)	0.750 (19.1)	1.375 (34.9)	1	500	B30-R6000
i3300, i5300, S3000, S3100, BBP30, BBP31, BBP33, BBP35, BBP37	Fig. 18c	B30EP-172-593-YL	Yellow	1.770 (45.0)	0.590 (15.0)	0.850 (21.6)	2.500 (63.5)	1	450	B30-R6000
i3300, i5300, S3000, S3100, BBP30, BBP31, BBP33, BBP35, BBP37	Fig. 18c	B30EP-175-593-YL	Yellow	3.000 (76.2)	0.750 (19.1)	1.000 (25.4)	3.250 (82.6)	1	375	B30-R6000
i3300, i5300, S3000, S3100, BBP30, BBP31, BBP33, BBP35, BBP37	Fig. 18c	B30EP-173-593-YL	Yellow	2.000 (50.8)	1.000 (25.4)	1.250 (31.8)	2.500 (63.5)	1	300	B30-R6000
i3300, i5300, S3000, S3100, BBP30, BBP31, BBP33, BBP35, BBP37	Fig. 18c	B30EP-174-593-YL	Yellow	4.000 (101.6)	1.000 (25.4)	1.250 (31.8)	4.250 (108.0)	1	300	B30-R6000
i3300, i5300, S3000, S3100, BBP30, BBP31, BBP33, BBP35, BBP37	Fig. 18c	B30EP-176-593-YL	Yellow	3.000 (76.2)	1.000 (25.4)	1.250 (31.8)	3.250 (82.6)	1	300	B30-R6000
i3300, i5300, S3000, S3100, BBP30, BBP31, BBP33, BBP35, BBP37	Fig. 18c	B30EP-177-593-YL	Yellow	3.000 (76.2)	2.500 (63.5)	2.750 (69.9)	3.250 (82.6)	1	125	B30-R6000
i3300, i5300, S3000, S3100, BBP30, BBP31, BBP33, BBP35, BBP37	Fig. 18c	B30EP-171-593-BK	Black	1.060 (26.9)	0.490 (12.5)	0.750 (19.1)	1.375 (34.9)	1	500	B30-R4400-WT
i3300, i5300, S3000, S3100, BBP30, BBP31, BBP33, BBP35, BBP37	Fig. 18c	B30EP-172-593-BK	Black	1.770 (45.0)	0.590 (15.0)	0.850 (21.6)	2.500 (63.5)	1	450	B30-R4400-WT
i3300, i5300, S3000, S3100, BBP30, BBP31, BBP33, BBP35, BBP37	Fig. 18c	B30EP-175-593-BK	Black	3.000 (76.2)	0.750 (19.1)	1.000 (25.4)	3.250 (82.6)	1	375	B30-R4400-WT
i3300, i5300, S3000, S3100, BBP30, BBP31, BBP33, BBP35, BBP37	Fig. 18c	B30EP-173-593-BK	Black	2.000 (50.8)	1.000 (25.4)	1.250 (31.8)	2.500 (63.5)	1	300	B30-R4400-WT
i3300, i5300, S3000, S3100, BBP30, BBP31, BBP33, BBP35, BBP37	Fig. 18c	B30EP-174-593-BK	Black	4.000 (101.6)	1.000 (25.4)	1.250 (31.8)	4.250 (108.0)	1	300	B30-R4400-WT
i3300, i5300, S3000, S3100, BBP30, BBP31, BBP33, BBP35, BBP37	Fig. 18c	B30EP-176-593-BK	Black	3.000 (76.2)	1.000 (25.4)	1.250 (31.8)	3.250 (82.6)	1	300	B30-R4400-WT
i3300, i5300, S3000, S3100, BBP30, BBP31, BBP33, BBP35, BBP37	Fig. 18c	B30EP-177-593-BK	Black	3.000 (76.2)	2.500 (63.5)	2.750 (69.9)	3.250 (82.6)	1	125	B30-R4400-WT
i3300, i5300, S3000, S3100, BBP30, BBP31, BBP33, BBP35, BBP37	Fig. 18c	B30EP-171-593-GN	Green	1.060 (26.9)	0.490 (12.5)	0.750 (19.1)	1.375 (34.9)	1	500	B30-R4400-WT
i3300, i5300, S3000, S3100, BBP30, BBP31, BBP33, BBP35, BBP37	Fig. 18c	B30EP-172-593-GN	Green	1.770 (45.0)	0.590 (15.0)	0.850 (21.6)	2.500 (63.5)	1	450	B30-R4400-WT
i3300, i5300, S3000, S3100, BBP30, BBP31, BBP33, BBP35, BBP37	Fig. 18c	B30EP-175-593-GN	Green	3.000 (76.2)	0.750 (19.1)	1.000 (25.4)	3.250 (82.6)	1	375	B30-R4400-WT
i3300, i5300, S3000, S3100, BBP30, BBP31, BBP33, BBP35, BBP37	Fig. 18c	B30EP-173-593-GN	Green	2.000 (50.8)	1.000 (25.4)	1.250 (31.8)	2.500 (63.5)	1	300	B30-R4400-WT
i3300, i5300, S3000, S3100, BBP30, BBP31, BBP33, BBP35, BBP37	Fig. 18c	B30EP-174-593-GN	Green	4.000 (101.6)	1.000 (25.4)	1.250 (31.8)	4.250 (108.0)	1	300	B30-R4400-WT
i3300, i5300, S3000, S3100, BBP30, BBP31, BBP33, BBP35, BBP37	Fig. 18c	B30EP-176-593-GN	Green	3.000 (76.2)	1.000 (25.4)	1.250 (31.8)	3.250 (82.6)	1	300	B30-R4400-WT
i3300, i5300, S3000, S3100, BBP30, BBP31, BBP33, BBP35, BBP37	Fig. 18c	B30EP-177-593-GN	Green	3.000 (76.2)	2.500 (63.5)	2.750 (69.9)	3.250 (82.6)	1	125	B30-R4400-WT
i3300, i5300, S3000, S3100, BBP30, BBP31, BBP33, BBP35, BBP37	Fig. 18c	B30EP-171-593-RD	Red	1.060 (26.9)	0.490 (12.5)	0.750 (19.1)	1.375 (34.9)	1	500	B30-R4400-WT
i3300, i5300, S3000, S3100, BBP30, BBP31, BBP33, BBP35, BBP37	Fig. 18c	B30EP-172-593-RD	Red	1.770 (45.0)	0.590 (15.0)	0.850 (21.6)	2.500 (63.5)	1	45	

## Panel Rating Plate Labels (B-486B, B-434A, B-8591, B-484, B-8117)

- Variety of UL rated materials in larger sizes for labeling panels and enclosures
- High or aggressive adhesive on all materials for rugged durability on smooth or rough panel surfaces
- Consult technical data sheet for complete performance, texting and ribbon use related to UL / CSA compliance

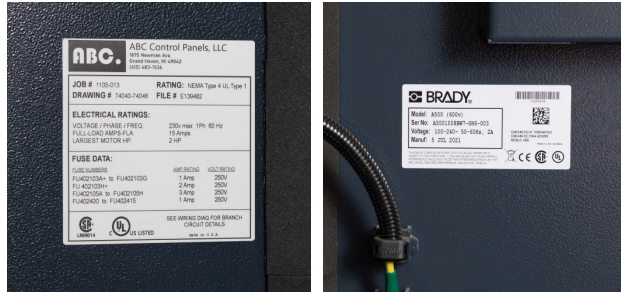
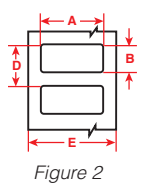

For Use with Printers:	Diagram	Catalog #	Color	Label width A inch (mm)	Label height B inch (mm)	Horiz. repeat C inch (mm)	Vert. repeat D inch (mm)	Web width E inch (mm)	Labels per row	Labels per roll	Rec. ribbon
<b>Ultra aggressive adhesive matte light gray metallized polyester for highly textured or powder-coated surfaces (B-486B)</b>											
i3300, i5300, BBP33	Fig. 2	B33-18-486	Matte Lt. Gray	3.000 (76.2)	1.000 (25.4)	-	1.125 (28.6)	3.200 (81.3)	1	1300	B30-R4300
i3300, i5300, BBP33	Fig. 2	B33-19-486	Matte Lt. Gray	3.000 (76.2)	2.000 (50.8)	-	2.125 (54.0)	3.200 (81.3)	1	500	B30-R4300
i3300, i5300, BBP33	Fig. 2	B33-55-486	Matte Lt. Gray	4.000 (101.6)	2.000 (50.8)	-	2.125 (54.0)	4.200 (106.7)	1	500	B30-R4300
i3300, i5300, BBP33	Fig. 2	B33-76-486	Matte Lt. Gray	4.000 (101.6)	3.000 (76.2)	-	3.125 (79.4)	4.200 (106.7)	1	500	B30-R4300
i3300, i5300, BBP33	Fig. 2	B33-161-486	Matte Lt. Gray	4.000 (101.6)	4.000 (101.6)	-	4.125 (104.8)	4.200 (106.7)	1	250	B30-R4300
<b>High-gloss silver metallized polyester with aggressive adhesive for textured surfaces (B-434A)</b>											
i3300, i5300, BBP33	Fig. 2	B33-18-434	Gloss Silver	3.000 (76.2)	1.000 (25.4)	-	1.125 (28.6)	3.200 (81.3)	1	1500	B30-R6000
i3300, i5300, BBP33	Fig. 2	B33-19-434	Gloss Silver	3.000 (76.2)	2.000 (50.8)	-	2.125 (54.0)	3.200 (81.3)	1	500	B30-R6000
i3300, i5300, BBP33	Fig. 2	B33-55-434	Gloss Silver	4.000 (101.6)	2.000 (50.8)	-	2.125 (54.0)	4.200 (106.7)	1	750	B30-R6000
i3300, i5300, BBP33	Fig. 2	B33-76-434	Gloss Silver	4.000 (101.6)	3.000 (76.2)	-	3.125 (79.3)	4.200 (106.7)	1	500	B30-R6000
i3300, i5300, BBP33	Fig. 2	B33-161-434	Gloss Silver	4.000 (101.6)	4.000 (101.6)	-	4.125 (104.7)	4.200 (106.7)	1	350	B30-R6000
i3300, i5300, BBP33	Fig. 2	B33-25-434	Gloss Silver	4.000 (101.6)	6.000 (152.4)	-	6.125 (155.5)	4.200 (106.7)	1	275	B30-R6000
<b>All-weather outdoor-grade polyester with metal appearance but non-metal construction (B-8591)</b>											
i3300, i5300, BBP33	Fig. 2	B33-18-8591-SL	Silver	3.000 (76.2)	1.000 (25.4)	-	1.125 (29.2)	3.200 (81.3)	1	1500	B30-R6600
i3300, i5300, BBP33	Fig. 2	B33-19-8591-SL	Silver	3.000 (76.2)	2.000 (50.8)	-	2.125 (54.0)	3.200 (81.3)	1	750	B30-R6600
i3300, i5300, BBP33	Fig. 2	B33-55-8591-SL	Silver	4.000 (101.6)	2.000 (50.8)	-	2.125 (54.0)	4.200 (106.7)	1	750	B30-R6600
i3300, i5300, BBP33	Fig. 2	B33-76-8591-SL	Silver	4.000 (101.6)	3.000 (76.2)	-	3.125 (79.3)	4.200 (106.7)	1	400	B30-R6600
i3300, i5300, BBP33	Fig. 2	B33-161-8591-SL	Silver	4.000 (101.6)	4.000 (101.6)	-	4.125 (104.8)	4.200 (106.7)	1	400	B30-R6600
i3300, i5300, BBP33	Fig. 2	B33-25-8591-SL	Silver	4.000 (101.6)	6.000 (152.4)	-	6.125 (155.6)	4.200 (106.7)	1	250	B30-R6600
<b>Aggressive adhesive flexible polyester for conforming to textured and angular or uneven surfaces (B-484A)</b>											
i3300, i5300, BBP33	Fig. 2	B33-18-484	Gloss White	3.000 (76.2)	1.000 (25.4)	-	1.125 (79.3)	3.200 (81.3)	1	1500	B30-R6000
i3300, i5300, BBP33	Fig. 2	B33-19-484	Gloss White	3.000 (76.2)	2.000 (50.8)	-	2.125 (54.0)	3.200 (81.3)	1	500	B30-R6000
i3300, i5300, BBP33	Fig. 2	B33-55-484	Gloss White	4.000 (101.6)	2.000 (50.8)	-	2.125 (54.0)	4.200 (106.7)	1	750	B30-R6000
i3300, i5300, BBP33	Fig. 2	B33-76-484	Gloss White	4.000 (101.6)	3.000 (76.2)	-	3.125 (79.3)	4.200 (106.7)	1	500	B30-R6000
i3300, i5300, BBP33	Fig. 2	B33-161-484	Gloss White	4.000 (101.6)	4.000 (101.6)	-	4.125 (79.3)	4.200 (106.7)	1	350	B30-R6000
i3300, i5300, BBP33	Fig. 2	B33-25-484	Gloss White	4.000 (101.6)	6.000 (152.4)	-	6.125 (155.5)	4.200 (106.7)	1	325	B30-R6000
<b>Matte black polyester with permanent adhesive for flat, smooth or lightly textured surfaces (B-8117)</b>											
i3300, i5300, BBP33	Fig. 2	B33-18-8117	Matte Black	3.000 (76.2)	1.000 (25.4)	-	1.125 (28.5)	3.350 (85.1)	1	1000	B30-R6800-WT
i3300, i5300, BBP33	Fig. 2	B33-19-8117	Matte Black	3.000 (76.2)	2.000 (50.8)	-	2.125 (54.0)	3.200 (81.3)	1	500	B30-R6800-WT
i3300, i5300, BBP33	Fig. 2	B33-55-8117	Matte Black	4.000 (101.6)	2.000 (50.8)	-	2.125 (54.0)	4.200 (106.7)	1	500	B30-R6800-WT
i3300, i5300, BBP33	Fig. 2	B33-76-8117	Matte Black	4.000 (101.6)	3.000 (76.2)	-	3.125 (79.3)	4.200 (106.7)	1	300	B30-R6800-WT
i3300, i5300, BBP33	Fig. 2	B33-161-8117	Matte Black	4.000 (101.6)	4.000 (101.6)	-	4.125 (104.7)	4.200 (106.7)	1	300	B30-R6800-WT
i3300, i5300, BBP33	Fig. 2	B33-25-8117	Matte Black	4.000 (101.6)	6.000 (152.4)	-	6.125 (155.5)	4.200 (106.7)	1	200	B30-R6800-WT

## UL-Rated Arc Flash Sign Headers (B-483A pre-print headers)

- Pre-printed headers with user-printable zone F below
- Create your custom layout or use Arc Flash templates in Brady WorkStation software Arc Flash App
- UL rated glossy ultra-high adhesion material adheres to smooth or highly textured, metal and non-metal surfaces

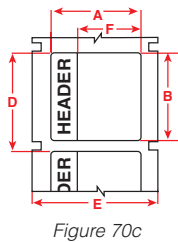

For Use with Printers:	Diagram	Catalog #	Header	Label width A inch (mm)	Label height B inch (mm)	Print height F inch (mm)	Vert. repeat D inch (mm)	Web width E inch (mm)	Labels per row	Labels per roll	Rec. ribbon
i3300, i5300, BBP33	Fig. 70c	B33-25-483-ANSIWA	WARNING	4.000 (101.6)	6.000 (152.4)	2.875 (73.0)	6.500 (165.1)	4.200 (106.7)	1	250	B30-R6000
i3300, i5300, BBP33	Fig. 70c	B33-161-483-ANSIWA	WARNING	4.000 (101.6)	4.000 (101.6)	2.875 (73.0)	4.500 (114.3)	4.200 (106.7)	1	370	B30-R6000
i3300, i5300, BBP33	Fig. 70c	B33-184-483-ANSIWA	WARNING	3.000 (76.2)	3.000 (76.2)	1.875 (47.6)	3.500 (88.9)	3.200 (81.3)	1	500	B30-R6000
i3300, i5300, BBP33	Fig. 70c	B33-25-483-ANSIDA	DANGER	4.000 (101.6)	6.000 (152.4)	2.875 (73.0)	6.500 (165.1)	4.200 (106.7)	1	250	B30-R6000
i3300, i5300, BBP33	Fig. 70c	B33-161-483-ANSIDA	DANGER	4.000 (101.6)	4.000 (101.6)	2.875 (73.0)	4.500 (114.3)	4.200 (106.7)	1	370	B30-R6000
i3300, i5300, BBP33	Fig. 70c	B33-184-483-ANSIDA	DANGER	3.000 (76.2)	3.000 (76.2)	1.875 (47.6)	3.500 (88.9)	3.200 (81.3)	1	500	B30-R6000

## Inside-Panel Component Labels (B-499, B-483A, B-484A, B-593)

- Various sizes in several durable material types
- Ideal for labeling backer board, relays, PLCs, switches, breakers, power supplies and other components inside panels
- All recommended materials are flexible or have extra high-tack adhesives for adhesion to wide variety of surfaces and components

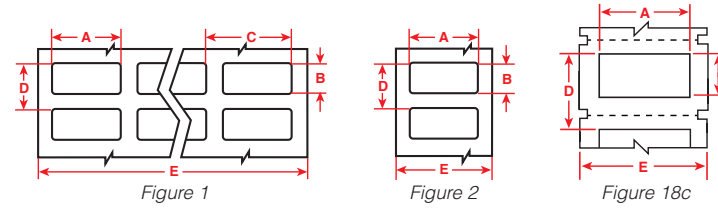

For Use with Printers:	Diagram	Catalog #	Color	Label width A inch (mm)	Label height B inch (mm)	Horiz. repeat C inch (mm)	Vert. repeat D inch (mm)	Web width E inch (mm)	Labels per row	Labels per roll	Rec. ribbon
<b>Nylon cloth with permanent adhesive for angled, curved and rough surfaces (B-499)</b>											
i3300, i5300, BBP33	Fig. 1	B33-68-499	White	0.500 (12.7)	0.750 (19.1)	0.600 (15.2)	0.875 (22.2)	2.500 (63.5)	4	1500	B30-R6200
i3300, i5300, BBP33	Fig. 1	B33-87-499	White	0.500 (12.7)	1.437 (36.4)	0.600 (15.2)	1.562 (39.7)	3.700 (94.0)	6	2500	B30-R6000
i3300, i5300, BBP33	Fig. 1	B33-1-499	White	0.750 (19.1)	0.250 (6.4)	0.800 (20.3)	0.350 (8.9)	3.350 (85.1)	4	10000	B30-R6000
i3300, i5300, BBP33	Fig. 1	B33-5-499	White	1.000 (25.4)	0.500 (12.7)	1.075 (27.3)	0.600 (15.2)	3.350 (85.1)	3	5000	B30-R6000
i3300, i5300, BBP33	Fig. 1	B33-88-499	White	1.000 (25.4)	0.750 (19.1)	1.100 (27.9)	0.875 (22.2)	2.300 (58.4)	2	2500	B30-R6000
i3300, i5300, BBP33	Fig. 1	B33-89-499	White	1.000 (25.4)	1.440 (36.5)	1.100 (27.9)	1.562 (39.7)	3.400 (86.4)	3	2300	B30-R6000
i3300, i5300, BBP33	Fig. 2	B33-136-499	White	1.500 (38.1)	0.750 (19.1)	-	0.875 (22.2)	1.770 (45.0)	1	1500	B30-R6000
i3300, i5300, BBP33	Fig. 2	B33-151-499	White	2.000 (50.8)	0.250 (6.4)	-	0.350 (8.9)	2.200 (55.9)	1	1500	B30-R4300
i3300, i5300, BBP33	Fig. 2	B33-137-499	White	2.000 (50.8)	1.000 (25.4)	-	1.125 (28.6)	2.200 (55.9)	1	1100	B30-R6000
<b>Ultra aggressive adhesive gloss polyester with aggressive adhesive for flat but highly textured surfaces (B-483A)</b>											
i3300, i5300, BBP33	Fig. 1	B33-12-483	Gloss White	0.500 (12.7)	0.437 (11.0)	0.662 (16.8)	0.537 (13.6)	3.350 (85.1)	5	10000	B30-R6000
i3300, i5300, BBP33	Fig. 1	B33-5-483	Gloss White	1.000 (25.4)	0.500 (12.7)	1.075 (27.3)	0.600 (15.2)	3.350 (85.1)	3	5000	B30-R6000
i3300, i5300, BBP33	Fig. 1	B33-37-483	Gloss White	1.500 (38.1)	0.500 (12.7)	1.650 (41.9)	0.600 (15.2)	3.350 (85.1)	2	5000	B30-R6000
i3300, i5300, BBP33	Fig. 1	B33-6-483	Gloss White	1.500 (38.1)	0.750 (19.1)	1.650 (41.9)	0.875 (22.2)	3.350 (85.1)	2	3300	B30-R6000
i3300, i5300, BBP33	Fig. 2	B33-53-483	Gloss White	2.000 (50.8)	0.500 (12.7)	-	0.600 (15.2)	2.200 (55.9)	1	2500	B30-R6000
i3300, i5300, BBP33	Fig. 2	B33-17-483	Gloss White	2.000 (50.8)	1.000 (25.4)	-	1.125 (28.6)	2.200 (55.9)	1	1500	B30-R6000
<b>Aggressive adhesive flexible polyester for conforming to textured and angular or uneven surfaces (B-484A)</b>											
i3300, i5300, BBP33	Fig. 2	B33-125-484	Gloss White	0.900 (22.9)	0.500 (12.7)	-	0.600 (15.2)	1.100 (27.9)	1	1500	B30-R6000
i3300, i5300, BBP33	Fig. 1	B33-5-484	Gloss White	1.000 (25.4)	0.500 (12.7)	1.075 (27.3)	0.600 (15.2)	3.350 (85.1)	3	5000	B30-R6000
i3300, i5300, BBP33	Fig. 2	B33-136-484	Gloss White	1.500 (38.1)	0.750 (19.1)	-	0.875 (22.2)	1.700 (43.2)	1	1500	B30-R6000
i3300, i5300, BBP33	Fig. 2	B33-17-484	Gloss White	2.000 (50.8)	1.000 (25.4)	-	1.125 (28.6)	2.200 (55.9)	1	1500	B30-R6000
<b>Raised profile polyester, thick, with extra-strength adhesive for textured surfaces (B-593)</b>											
i3300, i5300, S3000, S3100, BBP30, BBP31, BBP33, BBP35, BBP37	Fig. 18c	B30EP-171-593-WT	White	1.060 (26.9)	0.490 (12.5)	-	0.750 (19.1)	1.375 (34.9)	1	500	B30-R6000
i3300, i5300, S3000, S3100, BBP30, BBP31, BBP33, BBP35, BBP37	Fig. 18c	B30EP-172-593-WT	White	1.770 (45.0)	0.590 (15.0)	-	0.850 (21.6)	2.500 (63.5)	1	450	B30-R6000
i3300, i5300, S3000, S3100, BBP30, BBP31, BBP33, BBP35, BBP37	Fig. 18c	B30EP-173-593-WT	White	2.000 (50.8)	1.000 (25.4)	-	1.250 (31.8)	2.500 (63.5)	1	300	B30-R6000

## Adhesive Strips for Terminal Blocks and Patch Panels (B-498, B-422)

- Specially designed narrow-width continuous label for alignment on terminal blocks and patch panels
- Available in permanent or repositionable adhesive, UL-rated

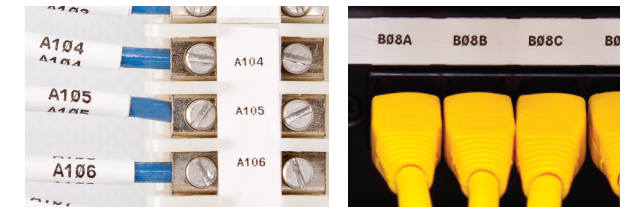
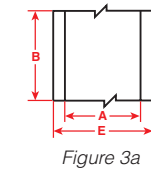

For Use with Printers:	Diagram	Catalog #	Color	Label width A inch (mm)	Roll Length B feet (m)	Web width E inch (mm)	Labels per roll	Rec. ribbon
<b>Vinyl Cloth - Aggressive but repositionable adhesive (B-498)</b>								
i3300, i5300, BBP33	Fig. 3a	B33C-312-498	Matte White	0.312 (7.9)	85 (25.9)	1.000 (25.4)	1 roll (cont.)	B30-R6200
i3300, i5300, BBP33	Fig. 3a	B33C-375-498	Matte White	0.375 (9.5)	85 (25.9)	1.000 (25.4)	1 roll (cont.)	B30-R6200
<b>Polyester - High gloss with permanent adhesive for smooth or textured surfaces (B-422)</b>								
i3300, i5300, BBP33	Fig. 3a	B33C-312-422	Gloss White	0.312 (7.9)	85 (25.9)	1.000 (25.4)	1 roll (cont.)	B30-R6000
i3300, i5300, BBP33	Fig. 3a	B33C-375-422	Gloss White	0.375 (9.5)	85 (25.9)	1.000 (25.4)	1 roll (cont.)	

## Self-Laminating Wire and Cable Wraps (B-427)

- Features white printable area with clear "tail" that wraps around cable or wire to protect printed text
- Standard adhesive designed to adhere to tightly curved surfaces inherent to wires and cables
- Self-extinguishing material with outstanding resistance to abrasion, handling, oil, water and dirt
- Use sizing formula and the "Label Length B" dimension when determining the correct size of marker for your cable or wire diameter and desired wrapping distance
- The "all white" parts are for flagging cables

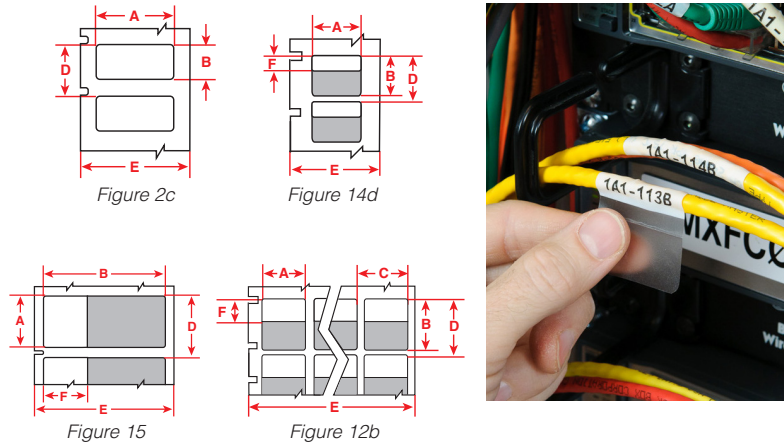

For Use with Printers:	Diagram	Catalog #	Color	Label width A inch (mm)	Label length B inch (mm)	Print Area F inch (mm)	Horiz. repeat C inch (mm)	Vert. repeat D inch (mm)	Web width E inch (mm)	Labels per row	Labels per roll	Rec. ribbon
<b>Self-laminating vinyl (B-427)</b>												
i3300, i5300, BBP33	Fig. 12b	B33-80-427	White/Clear	0.500 (12.7)	0.750 (19.1)	0.375 (9.5)	0.600 (15.2)	0.950 (24.1)	2.500 (63.5)	4	2500	B30-R4300
i3300, i5300, BBP33	Fig. 12b	B33-113-427	White/Clear	0.500 (12.7)	1.000 (25.4)	0.375 (9.5)	0.600 (15.2)	1.125 (28.6)	2.500 (63.5)	4	2500	B30-R4300
i3300, i5300, BBP33	Fig. 12b	B33-114-427	White/Clear	0.500 (12.7)	1.250 (31.8)	0.500 (12.7)	0.600 (15.2)	1.375 (34.9)	2.500 (63.5)	4	4000	B30-R4300
i3300, i5300, BBP33	Fig. 12b	B33-8-427	White/Clear	0.500 (12.7)	1.437 (36.5)	0.500 (12.7)	0.662 (16.8)	1.625 (41.3)	3.350 (85.1)	5	5000	B30-R4300
i3300, i5300, BBP33	Fig. 12b	B33-56-427	White/Clear	0.750 (19.1)	0.937 (23.8)	0.375 (9.5)	0.800 (20.3)	1.125 (28.6)	3.350 (85.1)	4	5000	B30-R4300
i3300, i5300, BBP33	Fig. 12b	B33-73-427	White/Clear	0.750 (19.1)	1.750 (44.6)	0.500 (12.7)	0.800 (20.3)	1.875 (47.6)	3.350 (85.1)	4	3500	B30-R4300
i3300, i5300, BBP33	Fig. 12b	B33-74-427	White/Clear	0.800 (20.3)	1.437 (36.5)	0.500 (12.7)	0.800 (20.3)	1.625 (41.3)	3.400 (86.4)	4	4000	B30-R4300
i3300, i5300, BBP33	Fig. 12b	B33-115-427	White/Clear	1.000 (25.4)	0.750 (19.1)	0.375 (9.5)	1.100 (27.9)	0.875 (22.2)	2.300 (58.4)	2	2500	B30-R4300
i3300, i5300, BBP33	Fig. 12b	B33-116-427	White/Clear	1.000 (25.4)	1.000 (25.4)	0.375 (9.5)	1.100 (27.9)	1.125 (28.6)	2.300 (58.4)	2	2500	B30-R4300
i3300, i5300, BBP33	Fig. 12b	B33-117-427	White/Clear	1.000 (25.4)	1.250 (31.8)	0.500 (12.7)	1.100 (27.9)	1.375 (34.9)	2.300 (58.4)	2	2000	B30-R4300
i3300, i5300, BBP33	Fig. 12b	B33-9-427	White/Clear	1.000 (25.4)	1.437 (36.5)	0.500 (12.7)	1.075 (27.3)	1.625 (41.3)	3.350 (85.1)	3	2500	B30-R4300
i3300, i5300, BBP33	Fig. 12b	B33-75-427	White/Clear	1.000 (25.4)	2.250 (57.2)	0.750 (19.1)	1.100 (27.9)	2.375 (60.3)	2.300 (58.4)	2	1400	B30-R4300
i3300, i5300, BBP33	Fig. 15	B33-131-427	White/Clear	1.000 (25.4)	2.625 (66.7)	1.000 (25.4)	-	1.250 (31.8)	2.825 (71.8)	1	1500	B30-R4300
i3300, i5300, BBP33	Fig. 12b	B33-10-427	White/Clear	1.000 (25.4)	3.750 (95.3)	1.000 (25.4)	1.075 (27.3)	4.000 (101.6)	3.350 (85.1)	3	1200	B30-R4300
i3300, i5300, BBP33	Fig. 12b	B33-81-427	White/Clear	1.000 (25.4)	6.000 (152.4)	1.500 (38.1)	1.100 (27.9)	6.187 (157.1)	2.300 (58.4)	2	500	B30-R4300
i3300, i5300, BBP33	Fig. 14d	B33-118-427	White/Clear	1.500 (38.1)	1.000 (25.4)	0.375 (9.5)	-	1.125 (28.6)	1.700 (43.2)	1	1250	B30-R4300
i3300, i5300, BBP33	Fig. 14d	B33-119-427	White/Clear	1.500 (38.1)	1.500 (38.1)	0.500 (12.7)	-	1.625 (41.3)	1.700 (43.2)	1	1000	B30-R4300
i3300, i5300, BBP33	Fig. 14d	B33-272-427	White/Clear	1.500 (38.1)	2.250 (57.2)	0.750 (19.1)	-	2.500 (63.5)	1.700 (43.2)	1	700	B30-R4300
i3300, i5300, BBP33	Fig. 14d	B33-120-427	White/Clear	1.750 (44.5)	1.000 (25.4)	0.375 (9.5)	-	1.125 (28.6)	1.950 (49.5)	1	1250	B30-R4300
i3300, i5300, BBP33	Fig. 14d	B33-121-427	White/Clear	1.750 (44.5)	1.500 (38.1)	0.500 (12.7)	-	1.750 (44.6)	1.950 (49.5)	1	1000	B30-R4300
i3300, i5300, BBP33	Fig. 14d	B33-273-427	White/Clear	1.750 (44.5)	2.250 (57.2)	0.750 (19.1)	-	2.500 (63.5)	1.950 (49.5)	1	500	B30-R4300
i3300, i5300, BBP33	Fig. 15	B33-66-427	White/Clear	1.900 (48.3)	3.187 (81.0)	0.750 (19.1)	-	2.150 (54.6)	3.387 (86.0)	1	700	B30-R4300
i3300, i5300, BBP33	Fig. 15	B33-67-427	White/Clear	2.000 (50.8)	2.250 (57.2)	0.750 (19.1)	-	2.187 (55.5)	2.450 (62.2)	1	700	B30-R4300
i3300, i5300, BBP33	Fig. 15	B33-369-427	White/Clear	2.000 (50.8)	3.750 (95.3)	1.000 (25.4)	-	2.250 (57.2)	3.950 (100.3)	1	700	B30-R4300
i3300, i5300, BBP33	Fig. 14d	B33-27-427	White/Clear	2.000 (50.8)	3.750 (95.3)	1.000 (25.4)	-	4.000 (101.6)	2.200 (55.9)	1	400	B30-R4300
i3300, i5300, BBP33	Fig. 14d	B33-82-427	White/Clear	2.000 (50.8)	6.000 (152.4)	1.500 (38.1)	-	6.187 (157.1)	2.200 (55.9)	1	200	B30-R4300
i3300, i5300, BBP33	Fig. 14d	B33-26-427	White/Clear	2.500 (63.5)	2.250 (57.2)	0.750 (19.1)	-	2.438 (61.9)	2.700 (68.8)	1	500	B30-R4300
i3300, i5300, BBP33	Fig. 2c	B33-137-427AW	White	2.000 (50.8)	1.000 (25.4)	-	-	1.125 (28.6)	2.200 (55.9)	1	1500	B30-R4300
i3300, i5300, BBP33	Fig. 2c	B33-135-427AW	White	1.500 (38.1)	0.750 (19.1)	-	-	0.875 (22.2)	1.700 (43.2)	1	1500	B30-R4300

## Aggressive Adhesive Self-Laminating Wire and Cable Wraps (B-417)

- Features white printable area with clear "tail" that wraps around cable or wire to protect printed text
- Advanced performance adhesive for standard wire and cable identification and also adhesion in high humidity conditions, on smaller diameter wires, and on challenging wire jacket materials including Teflon®, silicone, braided and traditional PVC.
- Self-extinguishing material with outstanding resistance to abrasion, handling, oil, water and dirt
- Use sizing formula and the "Label Length B" dimension when determining the correct size of marker for your cable or wire diameter and desired wrapping distance

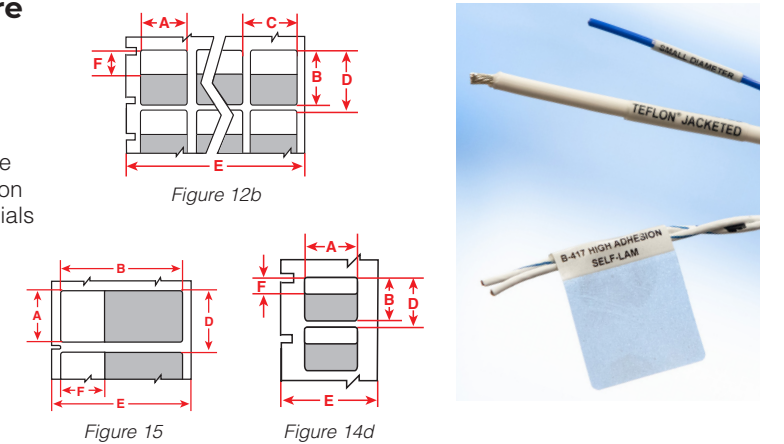

For Use with Printers:	Diagram	Catalog #	Color	Label width A inch (mm)	Label length B inch (mm)	Print Area F inch (mm)	Horiz. repeat C inch (mm)	Vert. repeat D inch (mm)	Web width E inch (mm)	Labels per row	Labels per roll	Rec. ribbon
<b>Aggressive Adhesive self-laminating vinyl (B-417)</b>												
i3300, i5300, BBP33	Fig. 12b	B33-80-417	White/Clear	0.500 (12.7)	0.750 (19.1)	0.375 (9.5)	0.600 (15.2)	0.950 (24.1)	2.500 (63.5)	4	2500	B30-R4300
i3300, i5300, BBP33	Fig. 12b	B33-113-417	White/Clear	0.500 (12.7)	1.000 (25.4)	0.375 (9.5)	0.600 (15.2)	1.125 (28.6)	2.500 (63.5)	4	2500	B30-R4300
i3300, i5300, BBP33	Fig. 12b	B33-114-417	White/Clear	0.500 (12.7)	1.250 (31.8)	0.500 (12.7)	0.600 (15.2)	1.375 (34.9)	2.500 (63.5)	4	4000	B30-R4300
i3300, i5300, BBP33	Fig. 12b	B33-8-417	White/Clear	0.500 (12.7)	1.437 (36.5)	0.500 (12.7)	0.662 (16.8)	1.625 (41.3)	3.350 (85.1)	5	5000	B30-R4300
i3300, i5300, BBP33	Fig. 12b	B33-56-417	White/Clear	0.750 (19.1)	0.937 (23.8)	0.375 (9.5)	0.800 (20.3)	1.125 (28.6)	3.350 (85.1)	4	5000	B30-R4300
i3300, i5300, BBP33	Fig. 12b	B33-73-417	White/Clear	0.750 (19.1)	1.750 (44.6)	0.500 (12.7)	0.800 (20.3)	1.875 (47.6)	3.350 (85.1)	4	3500	B30-R4300
i3300, i5300, BBP33	Fig. 12b	B33-74-417	White/Clear	0.800 (20.3)	1.437 (36.5)	0.500 (12.7)	0.800 (20.3)	1.625 (41.3)	3.400 (86.4)	4	4000	B30-R4300
i3300, i5300, BBP33	Fig. 12b	B33-116-417	White/Clear	1.000 (25.4)	1.000 (25.4)	0.375 (9.5)	1.100 (27.9)	1.125 (28.6)	2.300 (58.4)	2	2500	B30-R4300
i3300, i5300, BBP33	Fig. 12b	B33-117-417	White/Clear	1.000 (25.4)	1.250 (31.8)	0.500 (12.7)	1.100 (27.9)	1.375 (34.9)	2.300 (58.4)	2	2000	B30-R4300
i3300, i5300, BBP33	Fig. 12b	B33-9-417	White/Clear	1.000 (25.4)	1.437 (36.5)	0.500 (12.7)	1.075 (27.3)	1.625 (41.3)	3.350 (85.1)	3	2500	B30-R4300
i3300, i5300, BBP33	Fig. 12b	B33-75-417	White/Clear	1.000 (25.4)	2.250 (57.2)	0.750 (19.1)	1.100 (27.9)	2.375 (60.3)	2.300 (58.4)	2	1400	B30-R4300
i3300, i5300, BBP33	Fig. 15	B33-131-417	White/Clear	1.000 (25.4)	2.625 (66.7)	1.000 (25.4)	-	1.250 (31.8)	2.825 (71.8)	1	1500	B30-R4300
i3300, i5300, BBP33	Fig. 12b	B33-10-417	White/Clear	1.000 (25.4)	3.750 (95.3)	1.000 (25.4)	1.075 (27.3)	4.000 (101.6)	3.350 (85.1)	3	1200	B30-R4300
i3300, i5300, BBP33	Fig. 12b	B33-81-417	White/Clear	1.000 (25.4)	6.000 (152.4)	1.500 (38.1)	1.100 (27.9)	6.187 (157.1)	2.300 (58.4)	2	500	B30-R4300
i3300, i5300, BBP33	Fig. 14d	B33-119-417	White/Clear	1.500 (38.1)	1.500 (38.1)	0.500 (12.7)	-	1.625 (41.3)	1.700 (43.2)	1	1000	B30-R4300
i3300, i5300, BBP33	Fig. 12b	B33-272-417	White/Clear	1.500 (38.1)	2.250 (57.2)	0.750 (19.1)	-	2.500 (63.5)	1.700 (43.2)	1	700	B30-R4300
i3300, i5300, BBP33	Fig. 15	B33-66-417	White/Clear	1.900 (48.3)	3.187 (81.0)	0.750 (19.1)	-	2.150 (54.6)	3.387 (86.0)	1	700	B30-R4300
i3300, i5300, BBP33	Fig. 15	B33-67-417	White/Clear	2.000 (50.8)	2.250 (57.2)	0.750 (19.1)	-	2.187 (55.5)	2.450 (62.2)	1	700	B30-R4300
i3300, i5300, BBP33	Fig. 15	B33-369-417	White/Clear	2.000 (50.8)	3.750 (95.3)	1.000 (25.4)	-	2.250 (57.2)	3.950 (100.3)	1	700	B30-R4300
i3300, i5300, BBP33	Fig. 14d	B33-27-417	White/Clear	2.000 (50.8)	3.750 (95.3)	1.000 (25.4)	-	4.000 (101.6)	2.200 (55.9)	1	400	B30-R4300
i3300, i5300, BBP33	Fig. 12b	B33-82-417	White/Clear	2.000 (50.8)	6.000 (152.4)	1.500 (38.1)	-	6.187 (157.1)	2.200 (55.9)	1	200	B30-R4300
i3300, i5300, BBP33	Fig. 14d	B33-26-417	White/Clear	2.500 (63.5)	2.250 (57.2)	0.750 (19.1)	-	2.438 (61.9)	2.700 (68.8)	1	500	B30-R4300

### How to choose the right size Self-Laminating marker for your wire or cable

If you know the outside diameter or circumference of your wire/cable, you can easily determine the correct total label length and white print area height by using the formula below

Formula **for total marker wrap** (incl clear tail): ensures 1.5 times wrap around wire—choose longer length than 1.5 if more wrapping is desired

- ▶ **Step 1:** (wire outside dia) X (3.147) = wire circumference
- ▶ **Step 2:** (circumference) X (1.5) = target label length "B" in part number charts

Formula **for white print area height** can also be used to assist in managing if or how far the white print area height "F" will wrap or if it overlaps itself—1.0 will deliver full wrap with no overlap

- ▶ **Step 1:** (wire outside dia) X (3.147) = wire circumference
- ▶ **Step 2:** (circumference) X (1.0) = target print area height "F" in part number chart that will not overlap itself

## Rotating Self-Laminating Wire and Cable Wraps (B-427)

- Allows rotation of an over-laminated label on the cable to prevent cable damage and allow viewing of entire label from any angle
- Increases print area due to improved viewing ability
- Final installed label has over-laminated text and spins freely on the cable
- Use B dimension when considering label length for "cable diameter fit"

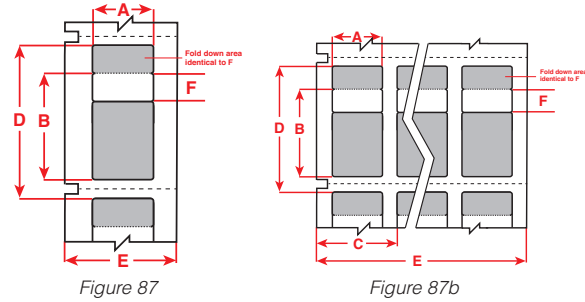

For Use with Printers:	Diagram	Catalog #	Color	Label width A inch (mm)	Label length B inch (mm)	Print Area F inch (mm)	Horiz. repeat C inch (mm)	Vert. repeat D inch (mm)	Web width E inch (mm)	Labels per row	Labels per roll	Rec. ribbon
i3300, i5300, BBP33	Fig. 87b	B33RO-292-427	White/Clear	0.500 (12.7)	1.750 (44.4)	0.700 (17.7)	0.700 (17.7)	2.575 (65.4)	2.100 (53.3)	3	1500	B30-R4300
i3300, i5300, BBP33	Fig. 87b	B33RO-293-427	White/Clear	0.500 (12.7)	2.750 (69.9)	1.100 (27.9)	0.700 (17.7)	4.063 (103.2)	2.100 (53.3)	3	900	B30-R4300
i3300, i5300, BBP33	Fig. 87b	B33RO-294-427	White/Clear	1.000 (25.4)	1.750 (44.4)	0.700 (17.7)	1.250 (31.8)	2.575 (65.4)	2.450 (62.2)	2	1000	B30-R4300
i3300, i5300, BBP33	Fig. 87b	B33RO-295-427	White/Clear	1.000 (25.4)	2.750 (69.9)	1.100 (27.9)	1.250 (31.8)	4.063 (103.2)	2.450 (62.2)	2	700	B30-R4300
i3300, i5300, BBP33	Fig. 87b	B33RO-296-427	White/Clear	1.000 (25.4)	3.125 (79.3)	1.250 (31.8)	1.250 (31.8)	4.563 (115.9)	2.450 (62.2)	2	600	B30-R4300
i3300, i5300, BBP33	Fig. 87b	B33RO-297-427	White/Clear	1.000 (25.4)	1.200 (30.4)	0.500 (12.7)	1.250 (31.8)	1.825 (46.4)	2.450 (62.2)	2	600	B30-R4300
i3300, i5300, BBP33	Fig. 87	B33RO-299-427	White/Clear	2.000 (50.8)	3.125 (79.3)	1.250 (31.8)	-	4.563 (115.9)	2.200 (55.9)	1	250	B30-R4300

## Rotating Self-Laminating Wrap Application:

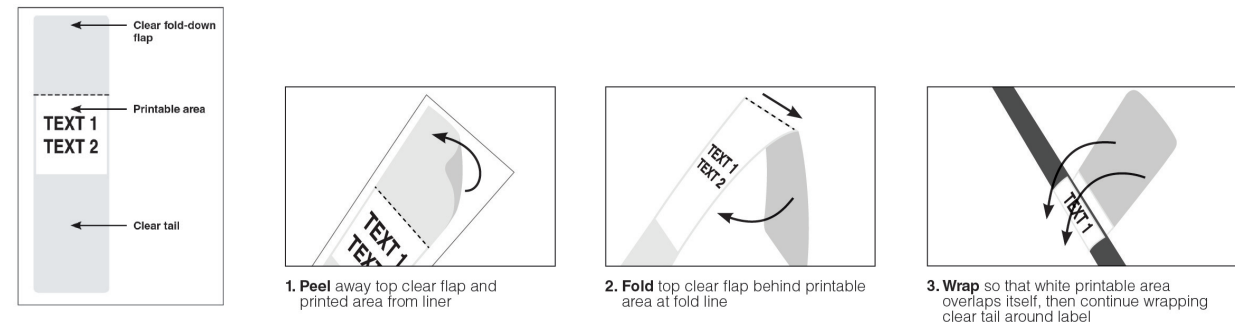

## QuickFlag™ Wire and Cable Flags (B-483A)

- Flag wires and cables faster with fewer re-wraps and fewer wasted labels
- Patent pending all white design features non-adhesive printable flag with tapered adhesive non-printable wrap-around tail which nearly eliminates mismatched edges or exposed adhesive on the final flag
- Fast – flagging is much faster eliminating time spent on tedious edge alignment at end of wrap
- Durable – made of durable polyester material that resists abrasions, temperatures of -40 to 248° F (-40 to 120° C), and solvents such as fuel, oil and water
- Permanent - ultra aggressive rubber-based adhesive on the tapered wrapping side
- 2 sizes including "wide" flag ideal for high-text-content datacomm applications
- UL Recognized to UL969, CSA accepted, RoHS Compliant to 2011/65/EU (Pass 2015/863)

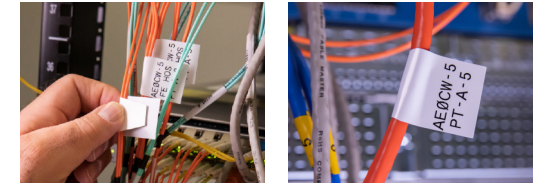
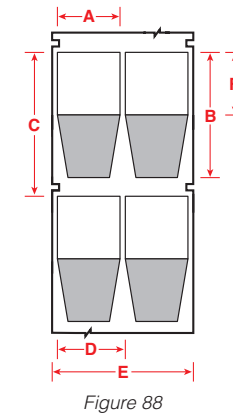

Faster Flagging with less waste

For Use with Printers:	Diagram	Catalog #	Color	Flag width A inch (mm)	Label length B inch (mm)	Printable Flag height F inch (mm)	Horiz. repeat C inch (mm)	Vert. repeat D inch (mm)	Web width E inch (mm)	Labels per row	Labels per roll	Rec. ribbon
i3300, i5300, BBP33	Fig. 88	B33-360-483	Gloss White	1.000 (25.4)	2.000 (50.8)	1.000 (25.4)	1.100 (27.9)	2.250 (57.2)	2.300 (58.4)	2	1500	B30-R6000
i3300, i5300, BBP33	Fig. 88	B33-361-483	Gloss White	1.900 (48.3)	2.000 (50.8)	1.000 (25.4)	2.100 (53.3)	2.250 (57.2)	4.200 (106.7)	2	1500	B30-R6000
i3300, i5300, BBP33	Fig. 88	B33-362-483	Gloss White	1.000 (25.4)	3.000 (76.2)	1.750 (44.5)	1.100 (27.9)	3.250 (82.6)	2.300 (58.4)	2	900	B30-R6000

## BradyGrip™ Print-on Hook Material featuring VELCRO® Brand Hook for cable/cord bundle Identification (B-414)

- Print your hook label, apply to VELCRO® Brand ONE-WRAP® roll and apply the complete solution to your cable or wire bundle
- Won't damage cables or wires the way nylon cable ties can
- A quick, repositionable and size-flexible identification solution for cable bundles that may need to be accessed and changed over time
- VELCRO® Brand ONE-WRAP® product not included with purchase

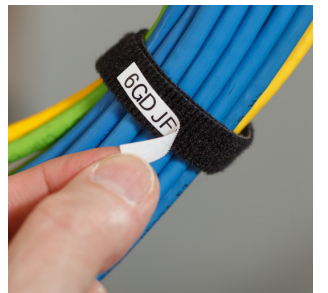
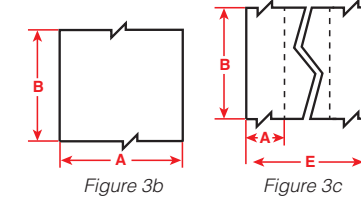

For Use with Printers:	Diagram	Catalog #	Color	Label width A inch (mm)	Roll Length B feet (m)	Web width E inch (mm)	Quantity of Strips	Labels per roll	Rec. ribbon
i3300, i5300, BBP33	Fig. 3c	B33C-250-414	Gloss White	0.250 (6.4)	50 (15.2)	0.750 (19.1)	3	1 roll (cont.)	B30-R6000
i3300, i5300, BBP33	Fig. 3c	B33C-500-414	Gloss White	0.500 (12.7)	50 (15.2)	1.000 (25.4)	2	1 roll (cont.)	B30-R6000
i3300, i5300, BBP33	Fig. 3b	B33C-750-414	Gloss White	0.750 (19.1)	50 (15.2)	n/a	1	1 roll (cont.)	B30-R6000

## Cloth Wire and Cable Wraps (B-498, B-499)

- Flexible materials conform very well to tightly curved surfaces
- B-498 has unique adhesive that provides excellent holding power to tightly curved surfaces and still allows for clean removal and multiple reapplications – an ideal choice for marking both ends of a wire that may need to be cut shorter before final termination
- Both multi-purpose materials are also excellent for labeling inside-of-panel components

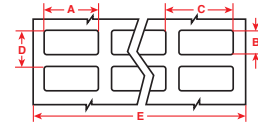

Figure 1

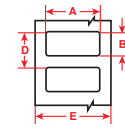
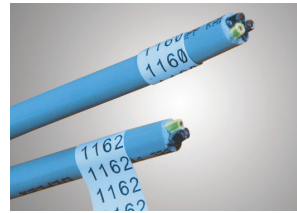

Figure 2



For Use with Printers:	Diagram	Catalog #	Color	Label width A inch (mm)	Label height B inch (mm)	Horiz. repeat C inch (mm)	Vert. repeat D inch (mm)	Web width E inch (mm)	Labels per row	Labels per roll	Rec. ribbon
<b>Repositionable vinyl cloth wire wraps (B-498)</b>											
i3300, i5300, BBP33	Fig. 1	B33-90-498	Matte White	0.250 (6.4)	1.437 (36.5)	0.350 (8.9)	1.562 (39.7)	2.200 (55.9)	6	2500	B30-R6200
i3300, i5300, BBP33	Fig. 1	B33-68-498	Matte White	0.500 (12.7)	0.750 (19.1)	0.600 (15.2)	0.875 (22.2)	2.500 (63.5)	4	5000	B30-R6200
i3300, i5300, BBP33	Fig. 1	B33-87-498	Matte White	0.500 (12.7)	1.437 (36.5)	0.600 (15.2)	1.562 (39.7)	3.700 (94.0)	6	2500	B30-R6200
i3300, i5300, BBP33	Fig. 1	B33-1-498	Matte White	0.750 (19.1)	0.250 (6.4)	0.800 (20.3)	0.350 (8.9)	3.350 (85.1)	4	5000	B30-R6200
i3300, i5300, BBP33	Fig. 2	B33-254-498	Matte White	0.750 (19.1)	0.750 (19.1)	-	0.850 (21.6)	1.000 (25.4)	1	1000	B30-R6200
i3300, i5300, BBP33	Fig. 1	B33-91-498	Matte White	0.750 (19.1)	0.937 (23.8)	0.850 (21.6)	1.062 (27.0)	3.500 (88.9)	4	2500	B30-R6200
i3300, i5300, BBP33	Fig. 1	B33-95-498	Matte White	0.800 (20.3)	1.437 (36.5)	0.900 (22.9)	1.562 (39.7)	2.800 (71.1)	3	2300	B30-R6200
i3300, i5300, BBP33	Fig. 1	B33-5-498	Matte White	1.000 (25.4)	0.500 (12.7)	1.075 (27.3)	0.600 (15.2)	3.350 (85.1)	3	5000	B30-R6200
i3300, i5300, BBP33	Fig. 1	B33-88-498	Matte White	1.000 (25.4)	0.750 (19.1)	1.100 (27.9)	0.875 (22.2)	2.300 (58.4)	2	2500	B30-R6200
i3300, i5300, BBP33	Fig. 1	B33-89-498	Matte White	1.000 (25.4)	1.437 (36.5)	1.100 (27.9)	1.562 (39.7)	3.400 (86.4)	3	2300	B30-R6200
i3300, i5300, BBP33	Fig. 1	B33-325-498	Matte White	1.000 (25.4)	2.500 (63.5)	1.150 (29.2)	2.625 (66.7)	2.350 (59.7)	2	700	B30-R6200
i3300, i5300, BBP33	Fig. 1	B33-326-498	Matte White	1.000 (25.4)	4.000 (101.6)	1.150 (29.2)	4.125 (104.8)	2.350 (59.7)	2	450	B30-R6200
i3300, i5300, BBP33	Fig. 1	B33-327-498	Matte White	1.500 (38.1)	4.000 (101.6)	1.650 (41.9)	4.125 (104.8)	3.350 (85.1)	2	450	B30-R6200
i3300, i5300, BBP33	Fig. 1	B33-328-498	Matte White	1.500 (38.1)	6.000 (152.4)	1.650 (41.9)	6.125 (155.6)	3.350 (85.1)	2	300	B30-R6200
<b>Permanent adhesive nylon cloth wire wraps (B-499)</b>											
i3300, i5300, BBP33	Fig. 1	B33-90-499	White	0.250 (6.4)	1.437 (36.4)	0.350 (8.9)	1.562 (39.7)	2.200 (55.9)	6	2500	B30-R6000
i3300, i5300, BBP33	Fig. 1	B33-68-499	White	0.500 (12.7)	0.750 (19.1)	0.600 (15.2)	0.875 (22.2)	2.500 (63.5)	4	1500	B30-R6200
i3300, i5300, BBP33	Fig. 1	B33-87-499	White	0.500 (12.7)	1.437 (36.4)	0.600 (15.2)	1.562 (39.7)	3.700 (94.0)	6	2500	B30-R6000
i3300, i5300, BBP33	Fig. 1	B33-1-499	White	0.750 (19.1)	0.250 (6.4)	0.800 (20.3)	0.350 (8.9)	3.350 (85.1)	4	10000	B30-R6000
i3300, i5300, BBP33	Fig. 2	B33-254-499	White	0.750 (19.1)	0.750 (19.1)	-	0.850 (21.6)	1.000 (25.4)	1	1000	B30-R6000
i3300, i5300, BBP33	Fig. 1	B33-91-499	White	0.750 (19.1)	0.937 (23.7)	0.850 (21.6)	1.062 (27.0)	3.500 (88.9)	4	2500	B30-R6000
i3300, i5300, BBP33	Fig. 1	B33-165-499	White	0.800 (20.3)	1.437 (36.5)	0.900 (22.9)	1.562 (39.7)	3.700 (94.0)	4	2500	B30-R6000
i3300, i5300, BBP33	Fig. 1	B33-5-499	White	1.000 (25.4)	0.500 (12.7)	1.075 (27.3)	0.600 (15.2)	3.350 (85.1)	3	5000	B30-R6000
i3300, i5300, BBP33	Fig. 1	B33-88-499	White	1.000 (25.4)	0.750 (19.1)	1.100 (27.9)	0.875 (22.2)	2.300 (58.4)	2	2500	B30-R6000
i3300, i5300, BBP33	Fig. 1	B33-89-499	White	1.000 (25.4)	1.440 (36.5)	1.100 (27.9)	1.562 (39.7)	3.400 (86.4)	3	2300	B30-R6000
i3300, i5300, BBP33	Fig. 1	B33-325-499	White	1.000 (25.4)	2.500 (63.5)	1.150 (29.2)	2.625 (66.7)	2.350 (59.7)	2	700	B30-R6000
i3300, i5300, BBP33	Fig. 1	B33-326-499	White	1.000 (25.4)	4.000 (101.6)	1.150 (29.2)	4.125 (104.8)	2.350 (59.7)	2	450	B30-R6000
i3300, i5300, BBP33	Fig. 1	B33-327-499	White	1.500 (38.1)	4.000 (101.6)	1.650 (41.9)	4.125 (104.8)	3.350 (85.1)	2	450	B30-R6000
i3300, i5300, BBP33	Fig. 1	B33-328-499	White	1.500 (38.1)	6.000 (152.4)	1.650 (41.9)	6.125 (155.6)	3.350 (85.1)	2	300	B30-R6000

## High-Temp Self-Extinguishing Tedlar® Wire Wraps (B-437)

- Top-coated polyvinyl fluoride label for wire and cable marking where high temperature and self-extinguishing features are required
- Heavy-duty performance with excellent resistance to water, oil and other fluids and meets MIL-M-87958 Standard
- Upper temp limit of up to 275°F – consult technical data sheet for full performance details

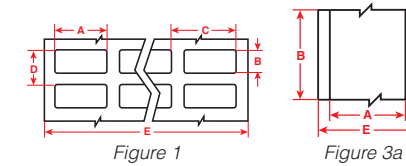

Figure 1

Figure 3a

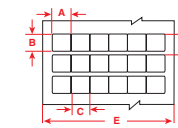

Figure 4



For Use with Printers:	Diagram	Catalog #	Color	Label width A inch (mm)	Label height B inch (mm)	Horiz. repeat C inch (mm)	Vert. repeat D inch (mm)	Web width E inch (mm)	Labels per row	Labels per roll	Rec. ribbon
i3300, i5300, BBP33	Fig. 4	B33-11-437	Matte White	0.250 (6.4)	0.250 (6.4)	0.250 (6.4)	0.375 (9.5)	3.200 (81.3)	12	15000	B30-R4300
i3300, i5300, BBP33	Fig. 1	B33-1-437	Matte White	0.750 (19.1)	0.250 (6.4)	0.800 (20.3)	0.350 (8.9)	3.350 (85.1)	4	5000	B30-R4300
i3300, i5300, BBP33	Fig. 1	B33-2-437	Matte White	0.900 (22.9)	0.250 (6.4)	1.125 (28.6)	0.350 (8.9)	3.350 (85.1)	3	5000	B30-R4300
i3300, i5300, BBP33	Fig. 1	B33-5-437	Matte White	1.000 (25.4)	0.500 (12.7)	1.075 (27.3)	0.600 (15.2)	3.350 (85.1)	3	5000	B30-R4300
i3300, i5300, BBP33	Fig. 1	B33-29-437	Matte White	1.250 (31.8)	0.375 (9.5)	1.300 (33.0)	0.475 (12.1)	2.750 (69.9)	2	5000	B30-R4300
i3300, i5300, BBP33	Fig. 1	B33-5-437YL	Matte Yellow	1.000 (25.4)	0.500 (12.7)	1.075 (27.3)	0.600 (15.2)	3.350 (85.1)	3	5000	B30-R4300
i3300, i5300, BBP33	Fig. 1	B33-29-437YL	Matte Yellow	1.250 (31.8)	0.375 (9.5)	1.300 (33.0)	0.475 (12.1)	2.750 (69.9)	2	5000	B30-R4300
<b>Continuous rolls</b>											
i3300, i5300, BBP33	Fig. 3a	B33C-1000-437	Matte White	1.000 (25.4)	85 ft. (25.9m)	-	-	1.200 (30.5)	1 roll (cont.)		B30-R4300
i3300, i5300, BBP33	Fig. 3a	B33C-1500-437	Matte White	1.500 (38.1)	85 ft. (25.9m)	-	-	1.900 (48.3)	1 roll (cont.)		B30-R4300
i3300, i5300, BBP33	Fig. 3a	B33C-2000-437	Matte White	2.000 (50.8)	85 ft. (25.9m)	-	-	2.200 (55.9)	1 roll (cont.)		B30-R4300
i3300, i5300, BBP33	Fig. 3a	B33C-3000-437	Matte White	3.000 (76.2)	85 ft. (25.9m)	-	-	3.400 (86.4)	1 roll (cont.)		B30-R4300
i3300, i5300, S3000, S3100, BBP30, BBP31, BBP33, BBP35, BBP37	Fig. 3a	B30C-4000-437	Matte White	4.000 (101.6)	100 ft. (30.5 m)	-	-	4.000 (101.6)	1 roll (cont.)		B30-R4300
i3300, i5300, BBP33	Fig. 3a	B33C-1000-437YL	Matte Yellow	1.000 (25.4)	85 ft. (25.9m)	-	-	1.200 (30.5)	1 roll (cont.)		B30-R4300
i3300, i5300, BBP33	Fig. 3a	B33C-1500-437YL	Matte Yellow	1.500 (38.1)	85 ft. (25.9m)	-	-	1.900 (48.3)	1 roll (cont.)		B30-R4300
i3300, i5300, BBP33	Fig. 3a	B33C-2000-437YL	Matte Yellow	2.000 (50.8)	85 ft. (25.9m)	-	-	2.200 (55.9)	1 roll (cont.)		B30-R4300
i3300, i5300, BBP33	Fig. 3a	B33C-3000-437YL	Matte Yellow	3.000 (76.2)	85 ft. (25.9m)	-	-	3.400 (86.4)	1 roll (cont.)		B30-R4300

Custom colors of Tedlar® labels are available for quote including: Gray, Pink, Blue, Green, Orange, Red, Violet - all require Black ribbon print.

## High-Temp Flame-Retardant Polyimide Wire Wraps (B-472)

- Top-coated polyimide label for wire and cable marking where high temperature and self-extinguishing features are required
- Heavy-duty performance with excellent resistance to water, oil and other fluids
- Upper temp limit of up to 320°F – consult technical data sheet for full performance details

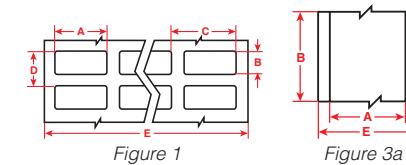

Figure 1

Figure 3a

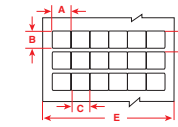

Figure 4



For Use with Printers:	Diagram	Catalog #	Color	Label width A inch (mm)	Label height B inch (mm)	Horiz. repeat C inch (mm)	Vert. repeat D inch (mm)	Web width E inch (mm)	Labels per row	Labels per roll	Rec. ribbon
i3300, i5300, BBP33	Fig. 4	B33-11-472	Matte White	0.250 (6.4)	0.250 (6.4)	0.250 (6.4)	0.375 (9.5)	3.200 (81.3)	12	15000	B30-R4300
i3300, i5300, BBP33	Fig. 1	B33-1-472	Matte White	0.750 (19.1)	0.250 (6.4)	0.800 (20.3)	0.350 (8.9)	3.350 (85.1)	4	5000	B30-R4300
i3300, i5300, BBP33	Fig. 1	B33-2-472	Matte White	0.900 (22.9)	0.250 (6.4)	1.125 (28.6)	0.350 (8.9)	3.350 (85.1)	3	5000	B30-R4300
i3300, i5300, BBP33	Fig. 1	B33-5-472	Matte White	1.000 (25.4)	0.500 (12.7)	1.075 (27.3)	0.600 (15.2)	3.350 (85.1)	3	5000	B30-R4300
i3300, i5300, BBP33	Fig. 1	B33-29-472	Matte White	1.250 (31.8)	0.375 (9.5)	1.300 (33.0)	0.475 (12.1)	2.750 (69.9)	2	5000	B30-R4300
i3300, i5300, BBP33	Fig. 1	B33-5-472YL	Matte Yellow	1.000 (25.4)	0.500 (12.7)	1.075 (27.3)	0.600 (15.2)	3.350 (85.1)	3	5000	B30-R4300
i3300, i5300, BBP33	Fig. 1	B33-29-472YL	Matte Yellow	1.250 (31.8)	0.375 (9.5)	1.300 (33.0)	0.475 (12.1)	2.750 (69.9)	2	5000	B30-R4300
<b>Continuous rolls</b>											
i3300, i5300, BBP33	Fig. 3a	B33C-1000-472	Matte White	1.000 (25.4)	85ft (25.9m)	-	-	1.200 (30.5)	1 roll (cont.)		B30-R4300
i3300, i5300, BBP33	Fig. 3a	B33C-1500-472	Matte White	1.500 (38.1)	85ft (25.9m)	-	-	1.900 (48.3)	1 roll (cont.)		B30-R4300
i3300, i5300, BBP33	Fig. 3a	B33C-2000-472	Matte White	2.000 (50.8)	85ft (25.9m)	-	-	2.200 (55.9)	1 roll (cont.)		B30-R4300
i3300, i5300, BBP33	Fig. 3a	B33C-3000-472	Matte White	3.000 (76.2)	85ft (25.9m)	-	-	3.400 (86.4)	1 roll (cont.)		B30-R4300
i3300, i5300, BBP33	Fig. 3a	B33C-1000-472YL	Matte Yellow	1.000 (25.4)	85ft (25.9m)	-	-	1.200 (30.5)	1 roll (cont.)		B30-R4300
i3300, i5300, BBP33	Fig. 3a	B33C-1500-472YL	Matte Yellow	1.500 (38.1)	85ft (25.9m)	-	-	1.900 (48.3)	1 roll (cont.)		B30-R4300
i3300, i5300, BBP33	Fig. 3a	B33C-2000-472YL	Matte Yellow	2.000 (50.8)	85ft (25.9m)	-	-	2.200 (55.9)	1 roll (cont.)		B30-R4300
i3300, i5300, BBP33	Fig. 3a	B33C-3000-472YL	Matte Yellow	3.000 (76.2)	85ft (25.9m)	-	-	3.400 (86.4)	1 roll (cont.)		B30-R4300



## PermaSleeve® Heat-Shrink Sleeves (B-342)

- Standard military / industrial grade heat-shrinkable wire marker with 3:1 shrink ratio
- Can be used for identification or wire protection
- Fade-resistant and flame-retardant
- Meets SAE-AS-23053/5 and SAE-AS-81531 specs
- Tested per ASTM E162, ASTM E662 and MIL-STD-202

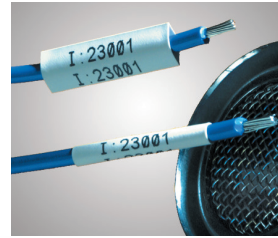
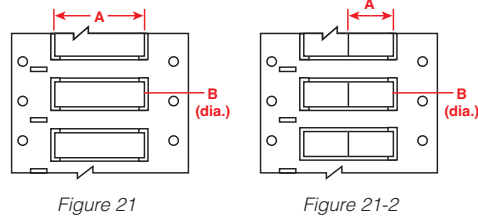

For Use with Printers:	Diagram	Catalog #	Color	For Wire Gauge (approx.)	For Wire Diameters Inch (mm) Min - Max.	Supplied Diameter B Inch (mm)	Recovered Diameter Inch (mm)	Recovered Wall Thickness Inch (mm)	Qty per Row	Qty per Roll	Rec. ribbon
<b>3:1 Shrink ratio, single-side printable, 2" sleeve width (dimension A)</b>											
i3300, i5300, BBP33	Fig. 21	B33-94-2-342	White	28 to 20	0.023 (0.6) - 0.080 (2.0)	0.094 (2.4)	0.024 (0.6)	0.024 (0.6) +/- 0.003 (0.07)	1	1000	B30-R4300
i3300, i5300, BBP33	Fig. 21	B33-125-2-342	White	22 to 16	0.046 (1.2) - 1.110 (2.8)	0.125 (3.2)	0.047 (1.2)	0.020 (0.5) +/- 0.003 (0.07)	1	1000	B30-R4300
i3300, i5300, BBP33	Fig. 21	B33-187-2-342	White	20 to 10	0.062 (1.6) - 0.150 (3.8)	0.187 (4.7)	0.062 (1.6)	0.020 (0.5) +/- 0.003 (0.07)	1	750	B30-R4300
i3300, i5300, BBP33	Fig. 21	B33-250-2-342	White	16 to 8	0.094 (2.4) - 0.215 (5.5)	0.250 (6.4)	0.093 (2.4)	0.025 (0.6) +/- 0.003 (0.07)	1	500	B30-R4300
i3300, i5300, BBP33	Fig. 21	B33-375-2-342	White	12 to 4	0.125 (3.2) - 0.320 (8.1)	0.375 (9.5)	0.125 (3.1)	0.025 (0.6) +/- 0.003 (0.07)	1	500	B30-R4300
i3300, i5300, BBP33	Fig. 21	B33-500-2-342	White	8 to 1	0.187 (4.8) - 0.450 (11.4)	0.500 (12.7)	0.187 (4.7)	0.025 (0.6) +/- 0.003 (0.07)	1	350	B30-R4300
i3300, i5300, BBP33	Fig. 21	B33-750-2-342	White	6 to 4/0	0.250 (6.4) - 0.700 (17.8)	0.750 (19.1)	0.250 (6.4)	0.025 (0.6) +/- 0.003 (0.07)	1	250	B30-R4300
i3300, i5300, BBP33	Fig. 21	B33-1000-2-342	White	2 to 0.950 dia	0.333 (8.5) - 0.950 (24.1)	1.000 (25.4)	0.375 (9.5)	0.036 (0.9) +/- 0.003 (0.07)	1	250	B30-R4300
i3300, i5300, BBP33	Fig. 21	B33-1500-2-342	White	n/a	0.500 (12.7) - 1.400 (35.6)	1.500 (38.1)	0.500 (12.7)	0.035 (0.9) +/- 0.003 (0.07)	1	150	B30-R4300
i3300, i5300, BBP33	Fig. 21	B33-94-2-342YL	Yellow	28 to 20	0.023 (0.6) - 0.080 (2.0)	0.094 (2.4)	0.024 (0.6)	0.024 (0.6) +/- 0.003 (0.07)	1	1000	B30-R4300
i3300, i5300, BBP33	Fig. 21	B33-125-2-342YL	Yellow	22 to 16	0.046 (1.2) - 1.110 (2.8)	0.125 (3.2)	0.047 (1.2)	0.020 (0.5) +/- 0.003 (0.07)	1	1000	B30-R4300
i3300, i5300, BBP33	Fig. 21	B33-187-2-342YL	Yellow	20 to 10	0.062 (1.6) - 0.150 (3.8)	0.187 (4.7)	0.062 (1.6)	0.020 (0.5) +/- 0.003 (0.07)	1	750	B30-R4300
i3300, i5300, BBP33	Fig. 21	B33-250-2-342YL	Yellow	16 to 8	0.094 (2.4) - 0.215 (5.5)	0.250 (6.4)	0.093 (2.4)	0.025 (0.6) +/- 0.003 (0.07)	1	500	B30-R4300
i3300, i5300, BBP33	Fig. 21	B33-375-2-342YL	Yellow	12 to 4	0.125 (3.2) - 0.320 (8.1)	0.375 (9.5)	0.125 (3.1)	0.025 (0.6) +/- 0.003 (0.07)	1	500	B30-R4300
i3300, i5300, BBP33	Fig. 21	B33-500-2-342YL	Yellow	8 to 1	0.187 (4.8) - 0.450 (11.4)	0.500 (12.7)	0.187 (4.7)	0.025 (0.6) +/- 0.003 (0.07)	1	350	B30-R4300
i3300, i5300, BBP33	Fig. 21	B33-750-2-342YL	Yellow	6 to 4/0	0.250 (6.4) - 0.700 (17.8)	0.750 (19.1)	0.250 (6.4)	0.025 (0.6) +/- 0.003 (0.07)	1	250	B30-R4300
i3300, i5300, BBP33	Fig. 21	B33-1000-2-342YL	Yellow	2 to 0.950 dia	0.333 (8.5) - 0.950 (24.1)	1.000 (25.4)	0.375 (9.5)	0.036 (0.9) +/- 0.003 (0.07)	1	250	B30-R4300
i3300, i5300, BBP33	Fig. 21	B33-1500-2-342YL	Yellow	n/a	0.500 (12.7) - 1.400 (35.6)	1.500 (38.1)	0.500 (12.7)	0.035 (0.9) +/- 0.003 (0.07)	1	150	B30-R4300
i3300, i5300, BBP33	Fig. 21	B33-94-2-342BK	Black	28 to 20	0.023 (0.6) - 0.080 (2.0)	0.094 (2.4)	0.024 (0.6)	0.024 (0.6) +/- 0.003 (0.07)	1	1000	B30-R4500-SV
i3300, i5300, BBP33	Fig. 21	B33-125-2-342BK	Black	22 to 16	0.046 (1.2) - 1.110 (2.8)	0.125 (3.2)	0.047 (1.2)	0.020 (0.5) +/- 0.003 (0.07)	1	1000	B30-R4500-SV
i3300, i5300, BBP33	Fig. 21	B33-187-2-342BK	Black	20 to 10	0.062 (1.6) - 0.150 (3.8)	0.187 (4.7)	0.062 (1.6)	0.020 (0.5) +/- 0.003 (0.07)	1	750	B30-R4500-SV
i3300, i5300, BBP33	Fig. 21	B33-250-2-342BK	Black	16 to 8	0.094 (2.4) - 0.215 (5.5)	0.250 (6.4)	0.093 (2.4)	0.025 (0.6) +/- 0.003 (0.07)	1	500	B30-R4500-SV
i3300, i5300, BBP33	Fig. 21	B33-375-2-342BK	Black	12 to 4	0.125 (3.2) - 0.320 (8.1)	0.375 (9.5)	0.125 (3.1)	0.025 (0.6) +/- 0.003 (0.07)	1	500	B30-R4500-SV
i3300, i5300, BBP33	Fig. 21	B33-500-2-342BK	Black	8 to 1	0.187 (4.8) - 0.450 (11.4)	0.500 (12.7)	0.187 (4.7)	0.025 (0.6) +/- 0.003 (0.07)	1	350	B30-R4500-SV
i3300, i5300, BBP33	Fig. 21	B33-750-2-342BK	Black	6 to 4/0	0.250 (6.4) - 0.700 (17.8)	0.750 (19.1)	0.250 (6.4)	0.025 (0.6) +/- 0.003 (0.07)	1	250	B30-R4500-SV
i3300, i5300, BBP33	Fig. 21	B33-1000-2-342BK	Black	2 to 0.950 dia	0.333 (8.5) - 0.950 (24.1)	1.000 (25.4)	0.375 (9.5)	0.036 (0.9) +/- 0.003 (0.07)	1	250	B30-R4500-SV
i3300, i5300, BBP33	Fig. 21	B33-1500-2-342BK	Black	n/a	0.500 (12.7) - 1.400 (35.6)	1.500 (38.1)	0.500 (12.7)	0.035 (0.9) +/- 0.003 (0.07)	1	150	B30-R4500-SV
<b>3:1 Shrink ratio, single-side printable, 1" sleeve width in "2-across precut" configuration (dimension A)</b>											
i3300, i5300, BBP33	Fig. 21-2	B33-94-2-342-2	White	28 to 20	0.023 (0.6) - 0.080 (2.0)	0.094 (2.4)	0.024 (0.6)	0.024 (0.6) +/- 0.003 (0.07)	2	2000	B30-R4300
i3300, i5300, BBP33	Fig. 21-2	B33-125-2-342-2	White	22 to 16	0.046 (1.2) - 0.111 (2.8)	0.125 (3.2)	0.047 (1.2)	0.020 (0.5) +/- 0.003 (0.07)	2	2000	B30-R4300
i3300, i5300, BBP33	Fig. 21-2	B33-187-2-342-2	White	20 to 10	0.062 (1.6) - 0.150 (3.8)	0.187 (4.7)	0.062 (1.6)	0.020 (0.5) +/- 0.003 (0.07)	2	1500	B30-R4300
i3300, i5300, BBP33	Fig. 21-2	B33-250-2-342-2	White	16 to 8	0.094 (2.4) - 0.215 (5.5)	0.250 (6.4)	0.093 (2.4)	0.025 (0.6) +/- 0.003 (0.07)	2	1000	B30-R4300
i3300, i5300, BBP33	Fig. 21-2	B33-375-2-342-2	White	12 to 4	0.125 (3.2) - 0.320 (8.1)	0.375 (9.5)	0.125 (3.1)	0.025 (0.6) +/- 0.003 (0.07)	2	1000	B30-R4300
i3300, i5300, BBP33	Fig. 21-2	B33-500-2-342-2	White	8 to 1	0.187 (4.8) - 0.450 (11.4)	0.500 (12.7)	0.119 (3.0)	0.025 (0.6) +/- 0.003 (0.07)	2	700	B30-R4300
i3300, i5300, BBP33	Fig. 21-2	B33-750-2-342-2	White	6 to 4/0	0.250 (6.4) - 0.700 (17.8)	0.750 (19.1)	0.250 (6.35)	0.025 (0.6) +/- 0.003 (0.07)	2	500	B30-R4300
i3300, i5300, BBP33	Fig. 21-2	B33-1000-2-342-2	White	2 to 0.950 dia	0.333 (8.5) - 0.950 (24.1)	1.000 (25.4)	0.375 (9.5)	0.036 (0.9) +/- 0.003 (0.07)	2	500	B30-R4300
i3300, i5300, BBP33	Fig. 21-2	B33-1500-2-342-2	White	n/a	0.500 (12.7) - 1.400 (35.6)	1.500 (38.1)	0.500 (12.7)	0.035 (0.9) +/- 0.003 (0.07)	2	150	B30-R4300
i3300, i5300, BBP33	Fig. 21-2	B33-94-2-342YL-2	Yellow	28 to 20	0.023 (0.6) - 0.080 (2.0)	0.094 (2.4)	0.024 (0.6)	0.024 (0.6) +/- 0.003 (0.07)	2	2000	B30-R4300
i3300, i5300, BBP33	Fig. 21-2	B33-125-2-342YL-2	Yellow	22 to 16	0.046 (1.2) - 0.111 (2.8)	0.125 (3.2)	0.047 (1.2)	0.020 (0.5) +/- 0.003 (0.07)	2	2000	B30-R4300
i3300, i5300, BBP33	Fig. 21-2	B33-500-2-342YL-2	Yellow	8 to 1	0.187 (4.8) - 0.450 (11.4)	0.500 (12.7)	0.119 (3.0)	0.025 (0.6) +/- 0.003 (0.07)	2	700	B30-R4300
i3300, i5300, BBP33	Fig. 21-2	B33-750-2-342YL-2	Yellow	6 to 4/0	0.250 (6.4) - 0.700 (17.8)	0.750 (19.1)	0.250 (6.35)	0.025 (0.6) +/- 0.003 (0.07)	2	500	B30-R4300
i3300, i5300, BBP33	Fig. 21-2	B33-1000-2-342YL-2	Yellow	2 to 0.950 dia	0.333 (8.5) - 0.950 (24.1)	1.000 (25.4)	0.375 (9.5)	0.036 (0.9) +/- 0.003 (0.07)	2	500	B30-R4300
i3300, i5300, BBP33	Fig. 21-2	B33-1500-2-342YL-2	Yellow	n/a	0.500 (12.7) - 1.400 (35.6)	1.500 (38.1)	0.500 (12.7)	0.035 (0.9) +/- 0.003 (0.07)	2	300	B30-R4300

For Use with Printers:	Diagram	Catalog #	Color	For Wire Gauge (approx.)	For Wire Diameters Inch (mm) Min - Max.	Supplied Diameter B Inch (mm)	Recovered Diameter Inch (mm)	Recovered Wall Thickness Inch (mm)	Qty per Row	Qty per Roll	Rec. ribbon
<b>3:1 Shrink ratio, Double-side printable, 2" sleeve width (dimension A)</b>											
i3300, i5300, BBP33	Fig. 21	B33D-94-2-342	White	28 to 20	0.023 (0.6) - 0.080 (2.0)	0.094 (2.4)	0.024 (0.6)	0.024 (0.6) +/- 0.003 (0.07)	1	1000	B30-R4300
i3300, i5300, BBP33	Fig. 21	B33D-94-2-342	White	22 to 16	0.046 (1.2) - 1.110 (2.8)	0.125 (3.2)	0.047 (1.2)	0.020 (0.5) +/- 0.003 (0.07)	1	1000	B30-R4300
i3300, i5300, BBP33	Fig. 21	B33D-125-2-342	White	22 to 16	0.046 (1.2) - 1.110 (2.8)	0.125 (3.2)	0.047 (1.2)	0.020 (0.5) +/- 0.003 (0.07)	1	1000	B30-R4300
i3300, i5300, BBP33	Fig. 21	B33D-187-2-342	White	20 to 10	0.062 (1.6) - 0.150 (3.8)	0.187 (4.7)	0.062 (1.6)	0.020 (0.5) +/- 0.003 (0.07)	1	750	B30-R4300
i3300, i5300, BBP33	Fig. 21	B33D-250-2-342	White	16 to 8	0.094 (2.4) - 0.215 (5.5)	0.250 (6.4)	0.093 (2.4)	0.025 (0.6) +/- 0.003 (0.07)	1	500	B30-R4300
i3300, i5300, BBP33	Fig. 21	B33D-375-2-342	White	12 to 4	0.125 (3.2) - 0.320 (8.1)	0.375 (9.5)	0.125 (3.1)	0.025 (0.6) +/- 0.003 (0.07)	1	500	B30-R4300
i3300, i5300, BBP33	Fig. 21	B33D-500-2-342	White	8 to 1	0.187 (4.8) - 0.450 (11.4)	0.500 (12.7)	0.187 (4.7)	0.025 (0.6) +/- 0.003 (0.07)	1	350	B30-R4300
i3300, i5300, BBP33	Fig. 21	B33D-750-2-342	White	6 to 4/0	0.250 (6.4) - 0.700 (17.8)	0.750 (19.1)	0.250 (6.4)	0.025 (0.6) +/- 0.003 (0.07)	1	250	B30-R4300
i3300, i5300, BBP33	Fig. 21	B33D-1000-2-342	White	2 to 0.950 dia	0.333 (8.5) - 0.950 (24.1)	1.000 (25.4)	0.375 (9.5)	0.036 (0.9) +/- 0.003 (0.07)	1	250	B30-R4300
i3300, i5300, BBP33	Fig. 21	B33D-1500-2-342	White	n/a	0.500 (12.7) - 1.400 (35.6)	1.500 (38.1)	0.500 (12.7)	0.035 (0.9) +/- 0.003 (0.07)	1	150	B30-R4300
i3300, i5300, BBP33	Fig. 21	B33D-94-2-342YL	Yellow	28 to 20	0.023 (0.6) - 0.080 (2.0)	0.094 (2.4)	0.024 (0.6)	0.024 (0.6) +/- 0.003 (0.07)	1	1000	B30-R4300
i3300, i5300, BBP33	Fig. 21	B33D-125-2-342YL	Yellow	22 to 16	0.046 (1.2) - 1.110 (2.8)	0.125 (3.2)	0.047 (1.2)	0.020 (0.5) +/- 0.003 (0.07)	1	1000	B30-R4300
i3300, i5300, BBP33	Fig. 21	B33D-187-2-342YL	Yellow	20 to 10	0.062 (1.6) - 0.150 (3.8)	0.187 (4.7)	0.062 (1.6)	0.020 (0.5) +/- 0.003 (0.07)	1	750	B30-R4300
i3300, i5300, BBP33	Fig. 21	B33D-250-2-342YL	Yellow	16 to 8	0.094 (2.4) - 0.215 (5.5)	0.250 (6.4)	0.093 (2.4)	0.025 (0.6) +/- 0.003 (0.07)	1	500	B30-R4300
i3300, i5300, BBP33	Fig. 21	B33D-375-2-342YL	Yellow	12 to 4	0.125 (3.2) - 0.320 (8.1)	0.375 (9.5)	0.125 (3.1)	0.025 (0.6) +/- 0.003 (0.07)	1	500	B30-R4300
i3300, i5300, BBP33	Fig. 21	B33D-500-2-342YL	Yellow	8 to 1	0.187 (4.8) - 0.450 (11.4)	0.500 (12.7)	0.187 (4.7)	0.025 (0.6) +/- 0.003 (0.07)	1	350	B30-R4300
i3300, i5300, BBP33	Fig. 21	B33D-750-2-342YL	Yellow	6 to 4/0	0.250 (6.4) - 0.700 (17.8)	0.750 (19.1)	0.250 (6.4)	0.025 (0.6) +/- 0.003 (0.07)	1	250	B30-R4300
i3300, i5300, BBP33	Fig. 21	B33D-1000-2-342YL	Yellow	2 to 0.950 dia	0.333 (8.5) - 0.950 (24.1)	1.000 (25.4)					

## PermaSleeve® Fluid-Resistant Heat-Shrink Sleeves (B-344)

- Designed for labeling wires with exposure to fuels, lubricants and harsh chemicals such as in the installation of hydrogen fuel cells in aerospace
- Resistant to harsh chemicals including JP8 Jet Fuel, Skydrol® and DOT 3 brake fluid
- Meets SAE-AS23053/5
- Tested per: ASTM E162, ASTM E662, MIL-STD-202G

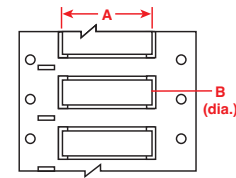

Figure 21



## PermaSleeve® High-Temp Heat-Shrink Sleeves (B-345)

- A 2:1 shrink ratio wire marker sleeve specifically designed for high-temperature and low-vacuum outgassing applications
- Made from irradiated high-temp polyvinylidene fluoride (PVDF) heat-shrink tubing
- Fade-resistant and flame-retardant
- Meets NASA SP-R-0022A Outgassing Performance
- Meets SAE-AS-81531
- Tested per ASTM E162, ASTM E662 and MIL-STD-202

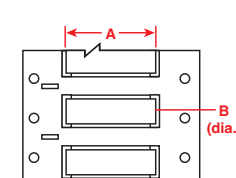
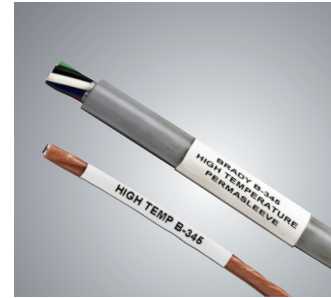

Figure 21



For Use with Printers:	Diagram	Catalog #	Color	For Wire Gauge (approx.)	For Wire Diameters Inch (mm) Min - Max.	Supplied Diameter B Inch (mm)	Recovered Diameter Inch (mm)	Recovered Wall Thickness Inch (mm)	Qty per Row	Qty per Roll	Rec. ribbon
<b>3:1 Shrink ratio, Double-side printable, 2" sleeve width (dimension A)</b>											
i3300, i5300, BBP33	Fig. 21	B33D-94-2-344	White	28 to 20	0.023 (0.6) - 0.080 (2.0)	0.094 (2.4)	0.024 (0.6)	0.024 (0.6) +/- 0.003 (0.1)	1	1000	B30-R6600
i3300, i5300, BBP33	Fig. 21	B33D-125-2-344	White	22 to 16	0.046 (1.2) - 0.111 (2.8)	0.125 (3.1)	0.047 (1.2)	0.020 (0.5) +/- 0.003 (0.1)	1	1000	B30-R6600
i3300, i5300, BBP33	Fig. 21	B33D-187-2-344	White	20 to 10	0.062 (1.6) - 0.15 (3.81)	0.187 (4.8)	0.062 (1.6)	0.020 (0.5) +/- 0.003 (0.1)	1	750	B30-R6600
i3300, i5300, BBP33	Fig. 21	B33D-250-2-344	White	16 to 8	0.094 (2.4) - 0.215 (5.5)	0.250 (6.35)	0.093 (2.4)	0.025 (0.6) +/- 0.003 (0.1)	1	500	B30-R6600
i3300, i5300, BBP33	Fig. 21	B33D-375-2-344	White	12 to 4	0.125 (3.2) - 0.320 (8.1)	0.375 (9.5)	0.125 (3.2)	0.025 (0.6) +/- 0.003 (0.1)	1	500	B30-R6600
i3300, i5300, BBP33	Fig. 21	B33D-500-2-344	White	8 to 1	0.187 (4.8) - 0.450 (11.4)	0.500 (12.7)	0.119 (3.0)	0.025 (0.6) +/- 0.003 (0.1)	1	350	B30-R6600
i3300, i5300, BBP33	Fig. 21	B33D-750-2-344	White	6 to 4/0	0.250 (6.4) - 0.700 (17.8)	0.750 (19.05)	0.250 (6.35)	0.025 (0.6) +/- 0.003 (0.1)	1	250	B30-R6600
i3300, i5300, BBP33	Fig. 21	B33D-1000-2-344	White	2 to 0.950 dia	0.333 (8.5) - 0.950 (24.1)	1.000 (25.4)	0.375 (9.5)	0.036 (0.9) +/- 0.003 (0.1)	1	250	B30-R6600
i3300, i5300, BBP33	Fig. 21	B33D-1500-2-344	White	n/a	0.500 (12.7) - 1.400 (35.6)	1.500 (38.1)	0.500 (12.7)	0.035 (0.9) +/- 0.003 (0.1)	1	150	B30-R6600
i3300, i5300, BBP33	Fig. 21	B33D-94-2-344YL	Yellow	28 to 20	0.023 (0.6) - 0.080 (2.0)	0.094 (2.4)	0.024 (0.6)	0.024 (0.6) +/- 0.003 (0.1)	1	1000	B30-R6600
i3300, i5300, BBP33	Fig. 21	B33D-125-2-344YL	Yellow	22 to 16	0.046 (1.2) - 0.111 (2.8)	0.125 (3.1)	0.047 (1.2)	0.020 (0.5) +/- 0.003 (0.1)	1	1000	B30-R6600
i3300, i5300, BBP33	Fig. 21	B33D-187-2-344YL	Yellow	20 to 10	0.062 (1.6) - 0.15 (3.81)	0.187 (4.8)	0.062 (1.6)	0.020 (0.5) +/- 0.003 (0.1)	1	750	B30-R6600
i3300, i5300, BBP33	Fig. 21	B33D-250-2-344YL	Yellow	16 to 8	0.094 (2.4) - 0.215 (5.5)	0.250 (6.35)	0.093 (2.4)	0.025 (0.6) +/- 0.003 (0.1)	1	500	B30-R6600
i3300, i5300, BBP33	Fig. 21	B33D-375-2-344YL	Yellow	12 to 4	0.125 (3.2) - 0.320 (8.1)	0.375 (9.5)	0.125 (3.2)	0.025 (0.6) +/- 0.003 (0.1)	1	500	B30-R6600
i3300, i5300, BBP33	Fig. 21	B33D-500-2-344YL	Yellow	8 to 1	0.187 (4.8) - 0.450 (11.4)	0.500 (12.7)	0.119 (3.0)	0.025 (0.6) +/- 0.003 (0.1)	1	350	B30-R6600
i3300, i5300, BBP33	Fig. 21	B33D-750-2-344YL	Yellow	6 to 4/0	0.250 (6.4) - 0.700 (17.8)	0.750 (19.05)	0.250 (6.35)	0.025 (0.6) +/- 0.003 (0.1)	1	250	B30-R6600
i3300, i5300, BBP33	Fig. 21	B33D-1000-2-344YL	Yellow	2 to 0.950 dia	0.333 (8.5) - 0.950 (24.1)	1.000 (25.4)	0.375 (9.5)	0.036 (0.9) +/- 0.003 (0.1)	1	250	B30-R6600
i3300, i5300, BBP33	Fig. 21	B33D-1500-2-344YL	Yellow	n/a	0.500 (12.7) - 1.400 (35.6)	1.500 (38.1)	0.500 (12.7)	0.035 (0.9) +/- 0.003 (0.1)	1	150	B30-R6600
i3300, i5300, BBP33	Fig. 21	B33D-94-2-344BK	Black	28 to 20	0.023 (0.6) - 0.080 (2.0)	0.094 (2.4)	0.024 (0.6)	0.024 (0.6) +/- 0.003 (0.1)	1	1000	B30-R6700-WT
i3300, i5300, BBP33	Fig. 21	B33D-125-2-344BK	Black	22 to 16	0.046 (1.2) - 0.111 (2.8)	0.125 (3.1)	0.047 (1.2)	0.020 (0.5) +/- 0.003 (0.1)	1	1000	B30-R6700-WT
i3300, i5300, BBP33	Fig. 21	B33D-187-2-344BK	Black	20 to 10	0.062 (1.6) - 0.15 (3.81)	0.187 (4.8)	0.062 (1.6)	0.020 (0.5) +/- 0.003 (0.1)	1	750	B30-R6700-WT
i3300, i5300, BBP33	Fig. 21	B33D-250-2-344BK	Black	16 to 8	0.094 (2.4) - 0.215 (5.5)	0.250 (6.35)	0.093 (2.4)	0.025 (0.6) +/- 0.003 (0.1)	1	500	B30-R6700-WT
i3300, i5300, BBP33	Fig. 21	B33D-375-2-344BK	Black	12 to 4	0.125 (3.2) - 0.320 (8.1)	0.375 (9.5)	0.125 (3.2)	0.025 (0.6) +/- 0.003 (0.1)	1	500	B30-R6700-WT
i3300, i5300, BBP33	Fig. 21	B33D-500-2-344BK	Black	8 to 1	0.187 (4.8) - 0.450 (11.4)	0.500 (12.7)	0.119 (3.0)	0.025 (0.6) +/- 0.003 (0.1)	1	350	B30-R6700-WT
i3300, i5300, BBP33	Fig. 21	B33D-750-2-344BK	Black	6 to 4/0	0.250 (6.4) - 0.700 (17.8)	0.750 (19.05)	0.250 (6.35)	0.025 (0.6) +/- 0.003 (0.1)	1	250	B30-R6700-WT
i3300, i5300, BBP33	Fig. 21	B33D-1000-2-344BK	Black	2 to 0.950 dia	0.333 (8.5) - 0.950 (24.1)	1.000 (25.4)	0.375 (9.5)	0.036 (0.9) +/- 0.003 (0.1)	1	250	B30-R6700-WT
i3300, i5300, BBP33	Fig. 21	B33D-1500-2-344BK	Black	n/a	0.500 (12.7) - 1.400 (35.6)	1.500 (38.1)	0.500 (12.7)	0.035 (0.9) +/- 0.003 (0.1)	1	150	B30-R6700-WT

For Use with Printers:	Diagram	Catalog #	Color	For Wire Gauge (approx.)	For Wire Diameters Inch (mm) Min - Max.	Supplied Diameter B Inch (mm)	Recovered Diameter Inch (mm)	Recovered Wall Thickness Inch (mm)	Qty per Row	Qty per Roll	Rec. ribbon
<b>3:1 Shrink ratio double-side printable, 2 in. sleeve width (dimension A)</b>											
i3300, i5300, BBP33	Fig. 21	B33D-94-2-345	White	26 to 20	0.031 (0.8) - 0.080 (2.0)	0.094 (2.4)	0.031 (0.8)	0.015 (0.4) +/- 0.003 (0.07)	1	1000	B30-R6000
i3300, i5300, BBP33	Fig. 21	B33D-94-2-345BK	Black	26 to 20	0.031 (0.8) - 0.080 (2.0)	0.094 (2.4)	0.031 (0.8)	0.015 (0.4) +/- 0.003 (0.07)	1	1000	B30-R4400-WT
<b>2:1 Shrink ratio double-side printable, 2 in. sleeve width (dimension A)</b>											
i3300, i5300, BBP33	Fig. 21	B33D-125-2-345	White	20 to 16	0.063 (1.6) - 0.110 (2.8)	0.125 (3.2)	0.062 (1.6)	0.015 (0.4) +/- 0.003 (0.07)	1	1000	B30-R6000
i3300, i5300, BBP33	Fig. 21	B33D-187-2-345	White	16 to 10	0.094 (2.4) - 0.150 (3.8)	0.187 (4.7)	0.093 (2.4)	0.015 (0.4) +/- 0.003 (0.07)	1	750	B30-R6000
i3300, i5300, BBP33	Fig. 21	B33D-250-2-345	White	12 to 8	0.125 (3.2) - 0.215 (5.5)	0.250 (6.4)	0.125 (3.2)	0.015 (0.4) +/- 0.003 (0.07)	1	500	B30-R6000
i3300, i5300, BBP33	Fig. 21	B33D-375-2-345	White	8 to 4	0.187 (3.2) - 0.320 (8.1)	0.375 (9.5)	0.187 (4.7)	0.015 (0.4) +/- 0.003 (0.07)	1	500	B30-R6000
i3300, i5300, BBP33	Fig. 21	B33D-500-2-345	White	6 to 1	0.250 (6.4) - 0.450 (11.4)	0.500 (12.7)	0.250 (6.4)	0.015 (0.4) +/- 0.003 (0.07)	1	350	B30-R6000
i3300, i5300, BBP33	Fig. 21	B33D-750-2-345	White	2 to 4/0	0.375 (9.5) - 0.700 (17.8)	0.750 (19.1)	0.375 (9.5)	0.015 (0.4) +/- 0.003 (0.07)	1	250	B30-R6000
i3300, i5300, BBP33	Fig. 21	B33D-1000-2-345	White	2/0 to 0.950 dia	0.450 (11.4) - 0.950 (24.1)	1.000 (25.4)	0.500 (12.7)	0.017 (0.4) +/- 0.004 (0.1)	1	250	B30-R6000
i3300, i5300, BBP33	Fig. 21	B33D-1500-2-345	White	N/A	0.750 (19.1) - 1.400 (35.6)	1.500 (38.1)	0.750 (19.1)	0.024 (0.6) +/- 0.004 (0.1)	1	150	B30-R6000
i3300, i5300, BBP33	Fig. 21	B33D-125-2-345BK	Black	20 to 16	0.063 (1.6) - 0.110 (2.8)	0.125 (3.2)	0.062 (1.6)	0.015 (0.4) +/- 0.003 (0.07)	1	1000	B30-R4400-WT
i3300, i5300, BBP33	Fig. 21	B33D-187-2-345BK	Black	16 to 10	0.094 (2.4) - 0.150 (3.8)	0.187 (4.7)	0.093 (2.4)	0.015 (0.4) +/- 0.003 (0.07)	1	750	B30-R4400-WT
i3300, i5300, BBP33	Fig. 21	B33D-250-2-345BK	Black	12 to 8	0.125 (3.2) - 0.215 (5.5)	0.250 (6.4)	0.125 (3.2)	0.015 (0.4) +/- 0.003 (0.07)	1	500	B30-R4400-WT
i3300, i5300, BBP33	Fig. 21	B33D-375-2-345BK	Black	8 to 4	0.187 (3.2) - 0.320 (8.1)	0.375 (9.5)	0.187 (4.7)	0.015 (0.4) +/- 0.003 (0.07)	1	500	B30-R4400-WT
i3300, i5300, BBP33	Fig. 21	B33D-500-2-345BK	Black	6 to 1	0.250 (6.4) - 0.450 (11.4)	0.500 (12.7)	0.250 (6.4)	0.015 (0.4) +/- 0.003 (0.07)	1	350	B30-R4400-WT
i3300, i5300, BBP33	Fig. 21	B33D-750-2-345BK	Black	3 to 4/0	0.375 (9.5) - 0.700 (17.8)	0.750 (19.1)	0.375 (9.5)	0.015 (0.4) +/- 0.003 (0.07)	1	250	B30-R4400-WT
i3300, i5300, BBP33	Fig. 21	B33D-1000-2-345BK	Black	2/0 to 0.950 dia	0.450 (11.4) - 0.950 (24.1)	1.000 (25.4)	0.500 (12.7)	0.017 (0.4) +/- 0.004 (0.1)	1	250	B30-R4400-WT
i3300, i5300, BBP33	Fig. 21	B33D-1500-2-345BK	Black	N/A	0.750 (19.1) - 1.400 (35.6)	1.500 (38.1)	0.750 (19.1)	0.024 (0.6) +/- 0.004 (0.1)	1	150	B30-R4400-WT

## PermaSleeve® Low Smoke Zero Halogen Heat-Shrink Sleeves (B-7641)

- Low halogen wire marking sleeves offer outstanding fire safety properties and minimal smoke emission
- Meets SAE-AS-81531 and EN45545-2
- Tested per ASTM E162, ASTM E662 and MIL-STD-202

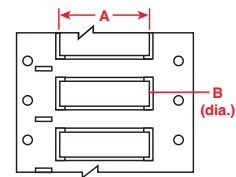

Figure 21



## PermaSleeve® 2:1 Heat-Shrink Sleeves (B-7642)

- Flame retardant and high-temp rated but not as high-temp as B-345 PermaSleeve
- Meets SAE-AS23053/5 and SAE-AS-81531
- Tested per ASTM E162, ASTM E662 and MIL-STD-202

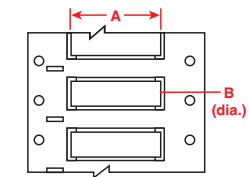

Figure 21



For Use with Printers:	Diagram	Catalog #	Color	For Wire Gauge (approx.)	For Wire Diameters Inch (mm) Min - Max.	Supplied Diameter B Inch (mm)	Recovered Diameter Inch (mm)	Recovered Wall Thickness Inch (mm)	Qty per Row	Qty per Roll	Rec. ribbon
<b>2:1 Shrink ratio double-side printable, 2 in. sleeve width (dimension A)</b>											
i3300, i5300, BBP33	Fig. 21	B33D-94-2-7641	White	24 to 20	0.047 (1.2) - 0.080 (2.0)	0.094 (2.4)	0.047 (1.2)	0.020 (0.5) +/- 0.003 (0.07)	1	500	B30-R6000
i3300, i5300, BBP33	Fig. 21	B33D-125-2-7641	White	20 to 16	0.062 (1.6) - 0.110 (2.8)	0.125 (3.2)	0.063 (1.6)	0.020 (0.5) +/- 0.003 (0.07)	1	500	B30-R6000
i3300, i5300, BBP33	Fig. 21	B33D-187-2-7641	White	16 to 10	0.094 (2.4) - 0.151 (3.8)	0.187 (4.8)	0.094 (2.4)	0.020 (0.5) +/- 0.003 (0.07)	1	450	B30-R6000
i3300, i5300, BBP33	Fig. 21	B33D-250-2-7641	White	12 to 8	0.125 (3.2) - 0.215 (5.5)	0.250 (6.4)	0.126 (3.2)	0.025 (0.6) +/- 0.003 (0.07)	1	400	B30-R6000
i3300, i5300, BBP33	Fig. 21	B33D-375-2-7641	White	8 to 4	0.188 (4.8) - 0.320 (8.1)	0.375 (9.5)	0.189 (4.8)	0.025 (0.6) +/- 0.003 (0.07)	1	250	B30-R6000
i3300, i5300, BBP33	Fig. 21	B33D-500-2-7641	White	6 to 1	0.250 (6.4) - 0.450 (11.4)	0.500 (12.7)	0.252 (6.4)	0.025 (0.6) +/- 0.003 (0.07)	1	225	B30-R6000
i3300, i5300, BBP33	Fig. 21	B33D-750-2-7641	White	2 to 4/0	0.375 (9.5) - 0.700 (17.8)	0.750 (19.1)	0.374 (9.5)	0.030 (0.8) +/- 0.003 (0.07)	1	150	B30-R6000
i3300, i5300, BBP33	Fig. 21	B33D-1000-2-7641	White	2/0 to 0.950 dia	0.450 (11.4) - 0.950 (24.1)	1.000 (25.4)	0.500 (12.7)	0.035 (0.9) +/- 0.005 (0.1)	1	150	B30-R6000
i3300, i5300, BBP33	Fig. 21	B33D-1500-2-7641	White	N/A	0.750 (19.1) - 1.400 (35.6)	1.500 (38.1)	0.752 (19.1)	0.040 (1.0) +/- 0.006 (0.2)	1	50	B30-R6000
i3300, i5300, BBP33	Fig. 21	B33D-94-2-7641Y	Yellow	24 to 20	0.047 (1.2) - 0.080 (2.0)	0.094 (2.4)	0.047 (1.2)	0.020 (0.5) +/- 0.003 (0.07)	1	500	B30-R6000
i3300, i5300, BBP33	Fig. 21	B33D-125-2-7641Y	Yellow	20 to 16	0.062 (1.6) - 0.110 (2.8)	0.125 (3.2)	0.063 (1.6)	0.020 (0.5) +/- 0.003 (0.07)	1	500	B30-R6000
i3300, i5300, BBP33	Fig. 21	B33D-187-2-7641Y	Yellow	16 to 10	0.094 (2.4) - 0.151 (3.8)	0.187 (4.8)	0.094 (2.4)	0.020 (0.5) +/- 0.003 (0.07)	1	450	B30-R6000
i3300, i5300, BBP33	Fig. 21	B33D-250-2-7641Y	Yellow	12 to 8	0.125 (3.2) - 0.215 (5.5)	0.250 (6.4)	0.126 (3.2)	0.025 (0.6) +/- 0.003 (0.07)	1	450	B30-R6000
i3300, i5300, BBP33	Fig. 21	B33D-375-2-7641Y	Yellow	8 to 4	0.188 (4.8) - 0.320 (8.1)	0.375 (9.5)	0.189 (4.8)	0.025 (0.6) +/- 0.003 (0.07)	1	250	B30-R6000
i3300, i5300, BBP33	Fig. 21	B33D-500-2-7641Y	Yellow	6 to 1	0.250 (6.4) - 0.450 (11.4)	0.500 (12.7)	0.252 (6.4)	0.025 (0.6) +/- 0.003 (0.07)	1	225	B30-R6000
i3300, i5300, BBP33	Fig. 21	B33D-750-2-7641Y	Yellow	2 to 4/0	0.375 (9.5) - 0.700 (17.8)	0.750 (19.1)	0.374 (9.5)	0.030 (0.8) +/- 0.003 (0.07)	1	150	B30-R6000
i3300, i5300, BBP33	Fig. 21	B33D-1000-2-7641Y	Yellow	2/0 to 0.950 dia	0.450 (11.4) - 0.950 (24.1)	1.000 (25.4)	0.500 (12.7)	0.035 (0.9) +/- 0.005 (0.1)	1	150	B30-R6000
i3300, i5300, BBP33	Fig. 21	B33D-1500-2-7641Y	Yellow	N/A	0.750 (19.1) - 1.400 (35.6)	1.500 (38.1)	0.752 (19.1)	0.040 (1.0) +/- 0.006 (0.2)	1	50	B30-R6000

For Use with Printers:	Diagram	Catalog #	Color	For Wire Gauge (approx.)	For Wire Diameters Inch (mm) Min - Max.	Supplied Diameter B Inch (mm)	Recovered Diameter Inch (mm)	Recovered Wall Thickness Inch (mm)	Qty per Row	Qty per Roll	Rec. ribbon
<b>2:1 Shrink ratio single-side printable, 2 in. sleeve width (dimension A)</b>											
i3300, i5300, BBP33	Fig. 21	B33-94-2-7642	White	24 to 20	0.047 (1.2) - 0.080 (2.0)	0.094 (2.4)	0.047 (1.2)	0.020 (0.5) +/- 0.003 (0.07)	1	500	B30-R4300
i3300, i5300, BBP33	Fig. 21	B33-125-2-7642	White	20 to 16	0.062 (1.6) - 0.110 (2.8)	0.125 (3.2)	0.063 (1.6)	0.020 (0.5) +/- 0.003 (0.07)	1	500	B30-R4300
i3300, i5300, BBP33	Fig. 21	B33-187-2-7642	White	16 to 10	0.094 (2.4) - 0.151 (3.8)	0.187 (4.8)	0.094 (2.4)	0.020 (0.5) +/- 0.003 (0.07)	1	450	B30-R4300
i3300, i5300, BBP33	Fig. 21	B33-250-2-7642	White	12 to 8	0.125 (3.2) - 0.215 (5.5)	0.250 (6.4)	0.126 (3.2)	0.025 (0.6) +/- 0.003 (0.07)	1	400	B30-R4300
i3300, i5300, BBP33	Fig. 21	B33-375-2-7642	White	8 to 4	0.188 (4.8) - 0.320 (8.1)	0.375 (9.5)	0.189 (4.8)	0.025 (0.6) +/- 0.003 (0.07)	1	250	B30-R4300
i3300, i5300, BBP33	Fig. 21	B33-500-2-7642	White	6 to 1	0.250 (6.4) - 0.450 (11.4)	0.500 (12.7)	0.252 (6.4)	0.025 (0.6) +/- 0.003 (0.07)	1	225	B30-R4300
i3300, i5300, BBP33	Fig. 21	B33-750-2-7642	White	2 to 4/0	0.375 (9.5) - 0.700 (17.8)	0.750 (19.1)	0.374 (9.5)	0.030 (0.8) +/- 0.003 (0.07)	1	150	B30-R4300
i3300, i5300, BBP33	Fig. 21	B33-1000-2-7642	White	2/0 to 0.950 dia	0.450 (11.4) - 0.950 (24.1)	1.000 (25.4)	0.500 (12.7)	0.035 (0.9) +/- 0.005 (0.1)	1	150	B30-R4300
i3300, i5300, BBP33	Fig. 21	B33-1500-2-7642	White	N/A	0.750 (19.1) - 1.400 (35.6)	1.500 (38.1)	0.752 (19.1)	0.040 (1.0) +/- 0.006 (0.2)	1	50	B30-R4300
i3300, i5300, BBP33	Fig. 21	B33-2000-2-7642	White	N/A	1.000 (25.4) - 1.900 (48.3)	2.000 (50.8)	1.000 (25.4)	0.045 (1.1) +/- 0.007 (0.2)	1	50	B30-R4300
<b>2:1 Shrink ratio, Double-side printable, 2 in. sleeve width (dimension A)</b>											
i3300, i5300, BBP33	Fig. 21	B33D-94-2-7642	White	24 to 20	0.047 (1.2) - 0.080 (2.0)	0.094 (2.4)	0.047 (1.2)	0.020 (0.5) +/- 0.003 (0.07)	1	500	B30-R4300
i3300, i5300, BBP33	Fig. 21	B33D-125-2-7642	White	20 to 16	0.062 (1.6) - 0.110 (2.8)	0.125 (3.2)	0.063 (1.6)	0.020 (0.5) +/- 0.003 (0.07)	1	500	B30-R4300
i3300, i5300, BBP33	Fig. 21	B33D-187-2-7642	White	16 to 10	0.094 (2.4) - 0.151 (3.8)	0.187 (4.8)	0.094 (2.4)	0.020 (0.5) +/- 0.003 (0.07)	1	450	B30-R4300
i3300, i5300, BBP33	Fig. 21	B33D-250-2-7642	White	12 to 8	0.125 (3.2) - 0.215 (5.5)	0.250 (6.4)	0.126 (3.2)	0.025 (0.6) +/- 0.003 (0.07)	1	400	B30-R4300
i3300, i5300, BBP33	Fig. 21	B33D-375-2-7642	White	8 to 4	0.188 (4.8) - 0.320 (8.1)	0.375 (9.5)	0.189 (4.8)	0.025 (0.6) +/- 0.003 (0.07)	1	250	B30-R4300
i3300, i5300, BBP33	Fig. 21	B33D-500-2-7642	White	6 to 1	0.250 (6.4) - 0.450 (11.4)	0.500 (12.7)	0.252 (6.4)	0.025 (0.6) +/- 0.003 (0.07)	1	225	B30-R4300
i3300, i5300, BBP33	Fig. 21	B33D-750-2-7642	White	2 to 4/0	0.375 (9.5) - 0.700 (17.8)	0.750 (19.1)	0.374 (9.5)	0.030 (0.8) +/- 0.003 (0.07)	1	150	B30-R4300
i3300, i5300, BBP33	Fig. 21	B33D-1000-2-7642	White	2/0 to 0.950 dia	0.450 (11.4) - 0.950 (24.1)	1.000 (25.4)	0.500 (12.7)	0.035 (0.9) +/- 0.005 (0.1)	1	150	B30-R4300
i3300, i5300, BBP33	Fig. 21	B33D-1500-2-7642	White	N/A	0.750 (19.1) - 1.400 (35.6)	1.500 (38.1)	0.752 (19.1)	0.040 (1.0) +/- 0.006 (0.2)	1	50	B30-R4300
i3300, i5300, BBP33	Fig. 21	B33D-2000-2-7642	White	N/A	1.000 (25.4) - 1.900 (48.3)	2.000 (50.8)	1.000 (25.4)	0.045 (1.1) +/- 0.007 (0.2)	1	50	B30-R4300

## Zero-Halogen Polyurethane Cable Markers (B-7643)

- Thermoplastic polyether polyurethane is a zero-halogen high-density, thermoplastic cable marker
- The non-adhesive tag is pre-cut with 4 holes and tag is fastened to cable or wire harness bundle with cable ties
- Meets the requirements of a halogen-free material per IEC 61249-2-21 (2003-11)
- Excellent chemical, oil and water resistance
- For use in i3300 and i5300 Printers only
- Recommended that cut-off is turned to "no cut" on printer

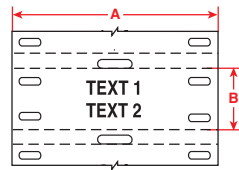

Figure 86



For Use with Printers:	Diagram	Catalog #	Color	Tag width A inch (mm)	Tag height B inch (mm)	Tags per row	Tags per roll	Rec. ribbon
i3300, i5300	Fig. 86	B33-60X10-7643-WT	White	2.360 (60.0)	0.390 (9.91)	1	750	B30-R6000
i3300, i5300	Fig. 86	B33-75X10-7643-WT	White	2.950 (75.0)	0.390 (9.91)	1	750	B30-R6000
i3300, i5300	Fig. 86	B33-75X15-7643-WT	White	2.950 (75.0)	0.590 (14.9)	1	500	B30-R6000
i3300, i5300	Fig. 86	B33-75X25-7643-WT	White	2.950 (75.0)	0.980 (24.9)	1	250	B30-R6000
i3300, i5300	Fig. 86	B33-60X10-7643-YL	Yellow	2.360 (60.0)	0.390 (9.91)	1	750	B30-R6000
i3300, i5300	Fig. 86	B33-75X10-7643-YL	Yellow	2.950 (75.0)	0.390 (9.91)	1	750	B30-R6000
i3300, i5300	Fig. 86	B33-75X15-7643-YL	Yellow	2.950 (75.0)	0.590 (14.9)	1	500	B30-R6000
i3300, i5300	Fig. 86	B33-75X25-7643-YL	Yellow	2.950 (75.0)	0.980 (24.9)	1	250	B30-R6000
i3300, i5300	Fig. 86	B33-60X10-7643-RD	Red	2.360 (60.0)	0.390 (9.91)	1	1000	B30-R6000
i3300, i5300	Fig. 86	B33-75X10-7643-RD	Red	2.950 (75.0)	0.390 (9.91)	1	750	B30-R6000
i3300, i5300	Fig. 86	B33-75X15-7643-RD	Red	2.950 (75.0)	0.590 (14.9)	1	500	B30-R6000
i3300, i5300	Fig. 86	B33-75X25-7643-RD	Red	2.950 (75.0)	0.980 (24.9)	1	250	B30-R6000

## QuickSleeve Handheld Sleeve Applicator

The QuickSleeve Handheld Sleeve Applicator is an intuitive multi-tool designed to help you quickly apply sleeves on to wires in three simple steps – just pick, slip and apply. This tool includes:

- Four specially designed slanted tubes sized for sleeve sizes 0.094, 0.125, 0.187 and 0.250 inches
- Built-in LED flashlight for use in low-lit conditions
- Terminal block sized screwdriver



Catalog #	Description	Qty.
QS	QuickSleeve multi-tool	1 Tool

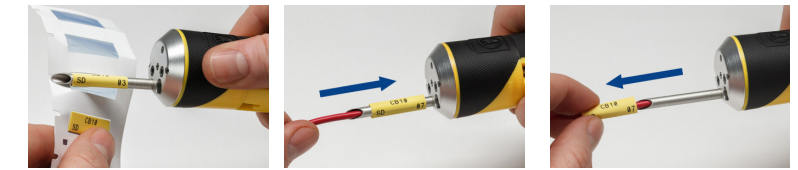

Pick

Slip

Apply

## Brady Heat Gun

The Brady Heat Gun provides fast, even shrinkage of BradySleeve™ and PermaSleeve™ markers or heat-shrinkable tubing. Deflector shield evenly distributes forced air heat (minimum temperature 500°F/260°C) around sleeves of up to 0.750 in. diameter for uniform shrinkage. Sturdy base with rubber pad allows hands-off operation.



Catalog #	Description	Qty.
PMS-HG-1	Brady Heat Gun	1 each

## Material External Rewinder

The Material External Rewinder from Brady® is positioned in front of Thermal Transfer Benchtop Printers from Brady to rewind material as it exits the printer.

- Rewind label rolls up to 5-inches in diameter at speeds up to 10 inches-per-second
- Adjustable core holder that adjusts easily to accept any core diameter from 1-inch to 4-inches
- A special motor offers bi-directional operation and trouble-free performance
- Rugged steel construction allows your material rewriter to be placed near your label printer



Catalog #	Description	Qty.
LBL-RWDR	BradyPrinter Rewinder	1 each

## Heavy Duty Polyester Tags (B-551, B-851)

- Non-adhesive polyester tag provides superior durability and outdoor performance over paper tags
- All tags are user-printable on front side only – pre-printed reverse side text options available
- Tags comply with OSHA 1910.145(f) when printed with required signal word and major message, and exceed 50lb pull test for lockout application
- Blank tags are ideal for general industrial and color coding applications
- Tags are pre-cut with large diameter mounting hole and are micro-perforated between tags to separate cleanly
- Snap-in plastic grommets available to add extra strength around mounting hole (catalog #20596, 100 per bag)

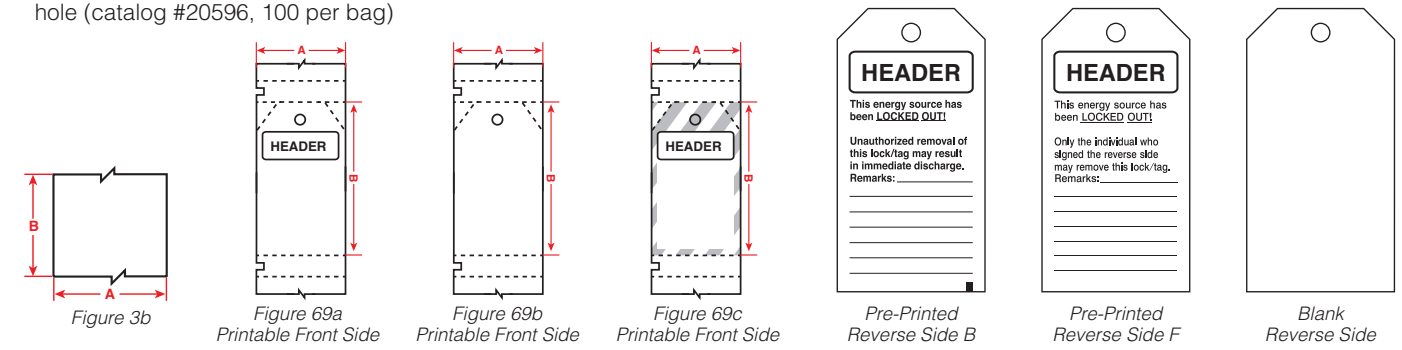

Diagram	Catalog #	Color	B#	Printable front side	Non-Printable Reverse side text	Tag width A	Tag length B	Tags per roll	Rec. ribbon
69c	B30-255-851OSHADSB	White w/Hdr	B-851			3.250 (82.6)	5.750 (146.1)	100	B30-R10000
69a	B30-255-851-ANSIDB	White w/Hdr	B-851			3.250 (82.6)	5.750 (146.1)	100	B30-R10000
69a	B30-255-851-OSHADB	White w/Hdr	B-851			3.250 (82.6)	5.750 (146.1)	100	B30-R10000
69b	B30-255-851-WHT-B	White	B-851			3.250 (82.6)	5.750 (146.1)	100	B30-R10000
69c	B30-255-851OSHADSF	White w/Hdr	B-851			3.250 (82.6)	5.750 (146.1)	100	B30-R10000
69a	B30-255-851-ANSIDF	White w/Hdr	B-851			3.250 (82.6)	5.750 (146.1)	100	B30-R10000
69a	B30-255-851-OSHADF	White w/Hdr	B-851			3.250 (82.6)	5.750 (146.1)	100	B30-R10000
69b	B30-255-851-WHT-F	White	B-851			3.250 (82.6)	5.750 (146.1)	100	B30-R10000
69c	B30-255-851-OST-BK	White w/Hdr	B-851			3.250 (82.6)	5.750 (146.1)	100	B30-R10000
69a	B30-255-851-ANSIDA	White w/Hdr	B-851			3.250 (82.6)	5.750 (146.1)	100	B30-R10000
69a	B30-255-851-OSHADA	White w/Hdr	B-851			3.250 (82.6)	5.750 (146.1)	100	B30-R10000
69a	B30-255-851-ANSICA	White w/Hdr	B-851			3.250 (82.6)	5.750 (146.1)	100	B30-R10000
69b	B30-255-851-WT	White	B-851			3.250 (82.6)	5.750 (146.1)	100	B30-R10000
69b	B30-255-851-RD	Red	B-851			3.250 (82.6)	5.750 (146.1)	100	B30-R10000
69b	B30-255-851-YL	Yellow	B-851			3.250 (82.6)	5.750 (146.1)	100	B30-R10000
69b	B30-255-851-GN	Green	B-851			3.250 (82.6)	5.750 (146.1)	100	B30-R10000
69b	B30-255-851-BL	Blue	B-851			3.250 (82.6)	5.750 (146.1)	100	B30-R10000
69b	B30-255-851-OR	Orange	B-851			3.250 (82.6)	5.750 (146.1)	100	B30-R10000
3b	B30C-2500-551-WT	White	B-551			2.500 (63.5)	50 ft. (15.2m)	1 roll (cont.)	B30-R10000
3b	B30C-3250-551-WT	White	B-551			3.250 (82.6)	50 ft. (15.2m)	1 roll (cont.)	B30-R10000
3b	B30C-4250-551-WT	White	B-551			4.250 (107.9)	50 ft. (15.2m)	1 roll (cont.)	B30-R10000

## Pre-Printed Pre-Cut Blank Sign Headers (B-595)

- Allows printer to create multicolor signs fast in a single print pass
- Headers meet NFPA 70E, OSHA 1910.145 and ASME / ANSI Z535 standards
- Indoor / outdoor grade material conforms to rough, highly textured and difficult-to-adhere-to surfaces

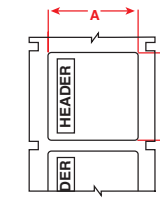

Figure 70a



Diagram	Catalog #	B#	Material	Header	Label Height A Inch (mm)	Label Width B Inch (mm)	Labels Per Row	Labels Per Roll	Rec. Ribbon
Fig. 70a	B30-241-595-OSHADA	B-595	Vinyl		2.250 (57.5)	3.000 (76.2)	1	300	B30-R10000
Fig. 70a	B30-25-595-OSHADA	B-595	Vinyl		4.000 (101.6)	6.000 (152.4)	1	175	B30-R10000
Fig. 70a	B30-241-595-OSHACA	B-595	Vinyl		2.250 (57.5)	3.000 (76.2)	1	300	B30-R10000
Fig. 70a	B30-25-595-OSHACA	B-595	Vinyl		4.000 (101.6)	6.000 (152.4)	1	175	B30-R10000
Fig. 70a	B30-241-595-ANSICA	B-595	Vinyl		2.250 (57.5)	3.000 (76.2)	1	300	B30-R10000
Fig. 70a	B30-25-595-ANSICA	B-595	Vinyl		4.000 (101.6)	6.000 (152.4)	1	175	B30-R10000
Fig. 70a	B30-241-595-ANSIDA	B-595	Vinyl		2.250 (57.5)	3.000 (76.2)	1	300	B30-R10000
Fig. 70a	B30-25-595-ANSIDA	B-595	Vinyl		4.000 (101.6)	6.000 (152.4)	1	175	B30-R10000
Fig. 70a	B30-241-595-ANSIWA	B-595	Vinyl		2.250 (57.5)	3.000 (76.2)	1	300	B30-R10000
Fig. 70a	B30-25-595-ANSIWA	B-595	Vinyl		4.000 (101.6)	6.000 (152.4)	1	175	B30-R10000
Fig. 70a	B30-241-595-ANSINO	B-595	Vinyl		2.250 (57.5)	3.000 (76.2)	1	300	B30-R10000
Fig. 70a	B30-25-595-ANSINO	B-595	Vinyl		4.000 (101.6)	6.000 (152.4)	1	175	B30-R10000
Fig. 70a	B30-25-595-PREC	B-595	Vinyl		4.000 (101.6)	6.000 (152.4)	1	175	B30-R10000
Fig. 70a	B30-25-595-PEL	B-595	Vinyl		4.000 (101.6)	6.000 (152.4)	1	175	B30-R10000
Fig. 70a	B30-242-595-BLNKWT	B-595	Vinyl		1.125 (28.6)	2.750 (69.9)	1	300	B30-R10000
Fig. 70a	B30-241-595-BLNKWT	B-595	Vinyl		2.250 (57.5)	3.000 (76.2)	1	300	B30-R10000
Fig. 70a	B30-219-595-BLNKWT	B-595	Vinyl		2.250 (57.5)	3.750 (95.3)	1	250	B30-R10000
Fig. 70a	B30-25-595-BLNKWT	B-595	Vinyl		4.000 (101.6)	6.000 (152.4)	1	175	B30-R10000
Fig. 70a	B30-241-595-BLNKYL	B-595	Vinyl		2.250 (57.5)	3.000 (76.2)	1	300	B30-R10000
Fig. 70a	B30-25-595-BLNKYL	B-595	Vinyl		4.000 (101.6)	6.000 (152.4)	1	175	B30-R10000



## ToughWash® Washdown Resistant Labels (B-854, B-855)

- Withstands high pressure, heat, harsh chemicals and numerous washdown cycles
- Legible and long-lasting for even the toughest washdown cycles
- Ideal for use in the food and beverage industry
- B-854 offers metal detectable layer to allow detection in food stream

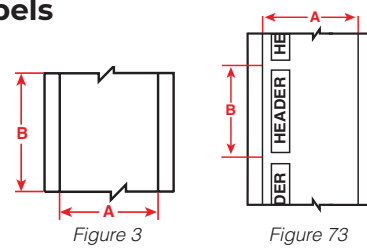
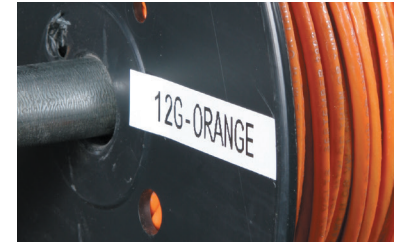
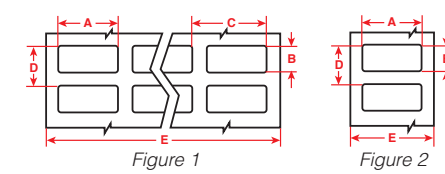

Diagram	Catalog #	B#	Color/Header	Label Width A Inch (mm)	Length B Inch (mm)	Labels Per Roll	Rec. Ribbon
<b>ToughWash Metal Detectable Material (B-854):</b>							
Fig. 3	B30C-4000-854-YL	B-854		4.000 (101.06)	50 ft. (15.2 m)	1 roll (cont.)	B30-R6000
Fig. 3	B30C-4000-854-WT	B-854		4.000 (101.06)	50 ft. (15.2 m)	1 roll (cont.)	B30-R6000
Fig. 73	B30-25-854-OSHADA	B-854		4.000 (101.06)	6.250 (158.8)	100	B30-R6000
Fig. 73	B30-25-854-ANSIWA	B-854		4.000 (101.06)	6.250 (158.8)	100	B30-R6000
Fig. 73	B30-25-854-ANSIDA	B-854		4.000 (101.06)	6.250 (158.8)	100	B30-R6000
Fig. 73	B30-25-854-ANSICA	B-854		4.000 (101.06)	6.250 (158.8)	100	B30-R6000
Fig. 73	B30-25-854-PEL	B-854		4.000 (101.06)	6.250 (158.8)	100	B30-R6000
Fig. 73	B30-25-854-PREC	B-854		4.000 (101.06)	6.250 (158.8)	100	B30-R6000
<b>ToughWash Material (B-855):</b>							
Fig. 3	B30C-1125-855-YL	B-855		1.125 (28.6)	50 ft. (15.2 m)	1 roll (cont.)	B30-R6000
Fig. 3	B30C-2250-855-YL	B-855		2.250 (57.5)	50 ft. (15.2 m)	1 roll (cont.)	B30-R6000
Fig. 3	B30C-4000-855-YL	B-855		4.000 (101.06)	50 ft. (15.2 m)	1 roll (cont.)	B30-R6000
Fig. 3	B30C-1125-855-WT	B-855		1.125 (28.6)	50 ft. (15.2 m)	1 roll (cont.)	B30-R6000
Fig. 3	B30C-2250-855-WT	B-855		2.250 (57.5)	50 ft. (15.2 m)	1 roll (cont.)	B30-R6000
Fig. 3	B30C-4000-855-WT	B-855		4.000 (101.06)	50 ft. (15.2 m)	1 roll (cont.)	B30-R6000
Fig. 73	B30-25-855-OSHADA	B-855		4.000 (101.06)	6.250 (158.8)	100	B30-R6000
Fig. 73	B30-25-855-ANSIWA	B-855		4.000 (101.06)	6.250 (158.8)	100	B30-R6000
Fig. 73	B30-25-855-ANSIDA	B-855		4.000 (101.06)	6.250 (158.8)	100	B30-R6000
Fig. 73	B30-25-855-ANSICA	B-855		4.000 (101.06)	6.250 (158.8)	100	B30-R6000
Fig. 73	B30-25-855-PEL	B-855		4.000 (101.06)	6.250 (158.8)	100	B30-R6000
Fig. 73	B30-25-855-PREC	B-855		4.000 (101.06)	6.250 (158.8)	100	B30-R6000

All part numbers above are compatible with BradyPrinter i3300, i5300, S3000, S3100, and BBP30, 31, 33, 35, 37 models. Visit BradyID.com to confirm compatibility.

## Chemical and Solvent Resistant Matte Polypropylene Labels (B-425A)

- Excellent solvent, fuel oil and liquids resistance
- Also has write-on ability for printed labels that require future hand-written data be added
- Flexible material conforms to irregular surfaces better than traditional polyesters
- Consult technical data sheet for UL / CSA ratings and complete performance and testing details



For Use with Printers:	Diagram	Catalog #	Color	Label width A inch (mm)	Label height B inch (mm)	Horiz. repeat C inch (mm)	Vert. repeat D inch (mm)	Web width E inch (mm)	Labels per row	Labels per roll	Rec. ribbon
i3300, i5300, BBP33	Fig. 1	B33-5-425	White	1.000 (25.4)	0.500 (12.7)	1.075 (27.3)	0.600 (15.2)	3.350 (85.1)	3	5000	B30-R4300
i3300, i5300, BBP33	Fig. 1	B33-6-425	White	1.500 (38.1)	0.750 (19.1)	1.650 (41.9)	0.875 (22.2)	3.350 (85.1)	2	3300	B30-R4300
i3300, i5300, BBP33	Fig. 2	B33-53-425	White	2.000 (50.8)	0.500 (12.7)	-	0.600 (15.2)	2.200 (55.9)	1	2000	B30-R4300
i3300, i5300, BBP33	Fig. 2	B33-17-425	White	2.000 (50.8)	1.000 (25.4)	-	1.125 (28.6)	2.200 (55.9)	1	1500	B30-R4300
i3300, i5300, BBP33	Fig. 2	B33-7-425	White	2.750 (69.9)	1.250 (31.8)	-	1.375 (34.9)	2.950 (74.9)	1	1000	B30-R4300
i3300, i5300, BBP33	Fig. 2	B33-18-425	White	3.000 (76.2)	1.000 (25.4)	-	1.125 (28.6)	3.200 (81.3)	1	1500	B30-R4300
i3300, i5300, BBP33	Fig. 2	B33-19-425	White	3.000 (76.2)	2.000 (50.8)	-	2.125 (54.0)	3.200 (81.3)	1	500	B30-R4300
i3300, i5300, BBP33	Fig. 2	B33-20-425	White	3.000 (76.2)	5.000 (127.0)	-	5.125 (130.1)	3.200 (81.3)	1	250	B30-R4300
i3300, i5300, BBP33	Fig. 2	B33-55-425	White	4.000 (101.6)	2.000 (50.8)	-	2.125 (53.9)	4.200 (106.7)	1	600	B30-R4300
i3300, i5300, BBP33	Fig. 2	B33-76-425	White	4.000 (101.6)	3.000 (76.2)	-	3.125 (79.3)	4.200 (106.7)	1	400	B30-R4300

## Retro Reflective All-Weather Labels (B-584)

- Highly reflective material shines back brightly when struck by light
- Ideal for labeling outdoor utility pedestals, hard hats, jobsite equipment and roof-top equipment
- Recommended for low light or inclement weather conditions

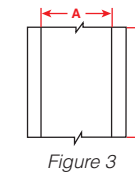

For Use with Printers:	Diagram	Catalog #	Color	Label Width A Inch (mm)	Roll Length B Feet (m)	Labels Per Roll	Rec. Ribbon
i3300, i5300, S3000, S3100, BBP30, BBP31, BBP33, BBP35, BBP37	Fig. 3	B30C-1125-584-SL	Silver	1.125 (28.6)	50 (15.2)	1 roll (cont.)	B30-R10000
i3300, i5300, S3000, S3100, BBP30, BBP31, BBP33, BBP35, BBP37	Fig. 3	B30C-2250-584-SL	Silver	2.250 (57.5)	50 (15.2)	1 roll (cont.)	B30-R10000
i3300, i5300, S3000, S3100, BBP30, BBP31, BBP33, BBP35, BBP37	Fig. 3	B30C-4000-584-SL	Silver	4.000 (101.6)	50 (15.2)	1 roll (cont.)	B30-R10000
i3300, i5300, S3000, S3100, BBP30, BBP31, BBP33, BBP35, BBP37	Fig. 3	B30C-1125-584-YL	Yellow	1.125 (28.6)	50 (15.2)	1 roll (cont.)	B30-R10000
i3300, i5300, S3000, S3100, BBP30, BBP31, BBP33, BBP35, BBP37	Fig. 3	B30C-2250-584-YL	Yellow	2.250 (57.5)	50 (15.2)	1 roll (cont.)	B30-R10000
i3300, i5300, S3000, S3100, BBP30, BBP31, BBP33, BBP35, BBP37	Fig. 3	B30C-4000-584-YL	Yellow	4.000 (101.6)	50 (15.2)	1 roll (cont.)	B30-R10000
i3300, i5300, S3000, S3100, BBP30, BBP31, BBP33, BBP35, BBP37	Fig. 3	B30C-1125-584-OR	Orange	1.125 (28.6)	50 (15.2)	1 roll (cont.)	B30-R10000
i3300, i5300, S3000, S3100, BBP30, BBP31, BBP33, BBP35, BBP37	Fig. 3	B30C-2250-584-OR	Orange	2.250 (57.5)	50 (15.2)	1 roll (cont.)	B30-R10000
i3300, i5300, S3000, S3100, BBP30, BBP31, BBP33, BBP35, BBP37	Fig. 3	B30C-4000-584-OR	Orange	4.000 (101.6)	50 (15.2)	1 roll (cont.)	B30-R10000

## BradyGlo™ High-Intensity Glow-in-the-Dark Labels (B-526)

- For glow-in-the-dark identification up to 10 hours
- Designed for directional, evacuation and equipment marking. Ideal for marking emergency utility shut-offs, fire extinguishers, alarm pulls and vital equipment controls
- Complies with indoor use requirements specified in RS 6-1 and 6-1A of New York Local Law 26

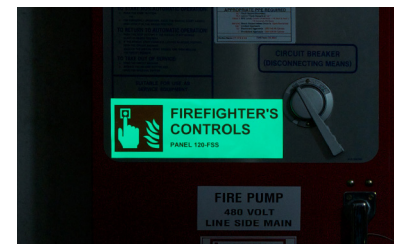
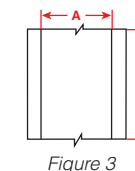

For Use with Printers:	Diagram	Catalog #	Color	Label Width A Inch (mm)	Roll Length B Feet (m)	Labels Per Roll	Rec. Ribbon
i3300, i5300, S3000, S3100, BBP30, BBP31, BBP33, BBP35, BBP37	Fig. 3	B30C-1125-526	Luminous Green	1.125 (28.6)	50 (15.2)	1 roll (cont.)	B30-R10000
i3300, i5300, S3000, S3100, BBP30, BBP31, BBP33, BBP35, BBP37	Fig. 3	B30C-2250-526	Luminous Green	2.250 (57.5)	50 (15.2)	1 roll (cont.)	B30-R10000
i3300, i5300, S3000, S3100, BBP30, BBP31, BBP33, BBP35, BBP37	Fig. 3	B30C-4000-526	Luminous Green	4.000 (101.6)	50 (15.2)	1 roll (cont.)	B30-R10000

## Printable Magnetic Labels (B-509)

- Easiest and quickest material for removing and repositioning
- Non-adhesive magnetic material that can be printed on directly
- Ideal for changing shelf storage locations, and reusable/repositionable Lean / 5S applications

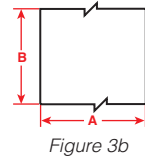

For Use with Printers:	Diagram	Catalog #	Color	Label Width A Inch (mm)	Roll Length B Feet (m)	Labels Per Roll	Rec. Ribbon
i3300, i5300, S3000, S3100, BBP30, BBP31, BBP33, BBP35, BBP37	Fig. 3b	B30C-2500-509-WT	White	2.500 (63.5)	25 (7.62)	1 roll (cont.)	B30-R10000
i3300, i5300, S3000, S3100, BBP30, BBP31, BBP33, BBP35, BBP37	Fig. 3b	B30C-4250-509-WT	White	4.250 (107.8)	25 (7.62)	1 roll (cont.)	B30-R10000
i3300, i5300, S3000, S3100, BBP30, BBP31, BBP33, BBP35, BBP37	Fig. 3b	B30C-2500-509-YL	Yellow	2.500 (63.5)	25 (7.62)	1 roll (cont.)	B30-R10000
i3300, i5300, S3000, S3100, BBP30, BBP31, BBP33, BBP35, BBP37	Fig. 3b	B30C-4250-509-YL	Yellow	4.250 (107.8)	25 (7.62)	1 roll (cont.)	B30-R10000

## Repositionable Multi-Purpose Vinyl (B-581)

- Aggressive adhesive stays in place but removes cleanly without leaving adhesive residue
- Ideal for temporary, removable and repositionable facility labels, such as Lean / 5S inventory labels

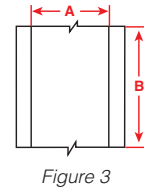

For Use with Printers:	Diagram	Catalog #	Color	Label Width A Inch (mm)	Roll Length B Feet (m)	Labels Per Roll	Rec. Ribbon
i3300, i5300, S3000, S3100, BBP30, BBP31, BBP33, BBP35, BBP37	Fig. 3	B30C-500-581-WT	White	0.500 (12.7)	100 (30.5)	1 roll (cont.)	B30-R10000
i3300, i5300, S3000, S3100, BBP30, BBP31, BBP33, BBP35, BBP37	Fig. 3	B30C-1125-581-WT	White	1.125 (28.6)	100 (30.5)	1 roll (cont.)	B30-R10000
i3300, i5300, S3000, S3100, BBP30, BBP31, BBP33, BBP35, BBP37	Fig. 3	B30C-2250-581-WT	White	2.250 (57.5)	100 (30.5)	1 roll (cont.)	B30-R10000
i3300, i5300, S3000, S3100, BBP30, BBP31, BBP33, BBP35, BBP37	Fig. 3	B30C-4000-581-WT	White	4.000 (101.6)	100 (30.5)	1 roll (cont.)	B30-R10000
i3300, i5300, S3000, S3100, BBP30, BBP31, BBP33, BBP35, BBP37	Fig. 3	B30C-500-581-YL	Yellow	0.500 (12.7)	100 (30.5)	1 roll (cont.)	B30-R10000
i3300, i5300, S3000, S3100, BBP30, BBP31, BBP33, BBP35, BBP37	Fig. 3	B30C-1125-581-YL	Yellow	1.125 (28.6)	100 (30.5)	1 roll (cont.)	B30-R10000
i3300, i5300, S3000, S3100, BBP30, BBP31, BBP33, BBP35, BBP37	Fig. 3	B30C-2250-581-YL	Yellow	2.250 (57.5)	100 (30.5)	1 roll (cont.)	B30-R10000
i3300, i5300, S3000, S3100, BBP30, BBP31, BBP33, BBP35, BBP37	Fig. 3	B30C-4000-581-YL	Yellow	4.000 (101.6)	100 (30.5)	1 roll (cont.)	B30-R10000

## Cold Temperature Application Labels (B-549)

- Special adhesive permanently adheres to extremely cold surfaces
- Can be applied in -10° F and lasts in -40° F
- Ideal for cold storage warehouses, coolers, freezers and short-term winter outdoor use

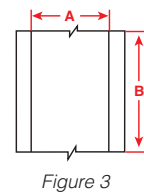

For Use with Printers:	Diagram	Catalog #	Color	Label Width A Inch (mm)	Roll Length B Feet (m)	Labels Per Roll	Rec. Ribbon
i3300, i5300, S3000, S3100, BBP30, BBP31, BBP33, BBP35, BBP37	Fig. 3	B30C-1125-549-WT	White	1.125 (28.6)	100 (30.5)	1 roll (cont.)	B30-R10000
i3300, i5300, S3000, S3100, BBP30, BBP31, BBP33, BBP35, BBP37	Fig. 3	B30C-2250-549-WT	White	2.250 (57.5)	100 (30.5)	1 roll (cont.)	B30-R10000
i3300, i5300, S3000, S3100, BBP30, BBP31, BBP33, BBP35, BBP37	Fig. 3	B30C-4000-549-WT	White	4.000 (101.6)	100 (30.5)	1 roll (cont.)	B30-R10000
i3300, i5300, S3000, S3100, BBP30, BBP31, BBP33, BBP35, BBP37	Fig. 3	B30C-1125-549-YL	Yellow	1.125 (28.6)	100 (30.5)	1 roll (cont.)	B30-R10000
i3300, i5300, S3000, S3100, BBP30, BBP31, BBP33, BBP35, BBP37	Fig. 3	B30C-2250-549-YL	Yellow	2.250 (57.5)	100 (30.5)	1 roll (cont.)	B30-R10000
i3300, i5300, S3000, S3100, BBP30, BBP31, BBP33, BBP35, BBP37	Fig. 3	B30C-4000-549-YL	Yellow	4.000 (101.6)	100 (30.5)	1 roll (cont.)	B30-R10000

## Pre-Printed GHS / CLP Chemical Labels (B-569, B-7569)

- Blank labels with pre-printed red diamonds allow the printer to produce 2-color GHS / CLP labels in one print pass
- Three sizes of labels, each with six diamond layouts that match templates in the printer app (if applicable) or in the Brady Workstation GHS App
- Indoor / outdoor vinyl material and durable inks withstand exposure to moisture, chemicals and handling



Catalog #	B#	Material	Legend	Label Height Inch (mm)	Label Width Inch (mm)	Labels Per Row	Labels Per Roll	Rec. Ribbon
B30-260-7569-CLP1	B-7569	Vinyl		2.170 (55.0)	3.350 (85.1)	1	340	B30-R10000
B30-261-7569-CLP1	B-7569	Vinyl		2.950 (75.0)	4.330 (110.0)	1	270	B30-R10000
B30-262-7569-CLP1	B-7569	Vinyl		4.130 (105.0)	6.100 (155.0)	1	200	B30-R10000
B30-260-7569-CLP2	B-7569	Vinyl		2.170 (55.0)	3.350 (85.1)	1	340	B30-R10000
B30-261-7569-CLP2	B-7569	Vinyl		2.950 (75.0)	4.330 (110.0)	1	270	B30-R10000
B30-262-7569-CLP2	B-7569	Vinyl		4.130 (105.0)	6.100 (155.0)	1	200	B30-R10000
B30-260-7569-CLP3A	B-7569	Vinyl		2.170 (55.0)	3.350 (85.1)	1	340	B30-R10000
B30-261-7569-CLP3A	B-7569	Vinyl		2.950 (75.0)	4.330 (110.0)	1	270	B30-R10000
B30-262-7569-CLP3A	B-7569	Vinyl		4.130 (105.0)	6.100 (155.0)	1	200	B30-R10000
B30-260-7569-CLP3B	B-7569	Vinyl		2.170 (55.0)	3.350 (85.1)	1	340	B30-R10000
B30-261-7569-CLP3B	B-7569	Vinyl		2.950 (75.0)	4.330 (110.0)	1	270	B30-R10000
B30-262-7569-CLP3B	B-7569	Vinyl		4.130 (105.0)	6.100 (155.0)	1	200	B30-R10000
B30-260-7569-CLP4A	B-7569	Vinyl		2.170 (55.0)	3.350 (85.1)	1	340	B30-R10000
B30-261-7569-CLP4A	B-7569	Vinyl		2.950 (75.0)	4.330 (110.0)	1	270	B30-R10000
B30-262-7569-CLP4A	B-7569	Vinyl		4.130 (105.0)	6.100 (155.0)	1	200	B30-R10000
B30-260-569-CLP4B	B-569	Polyester		2.170 (55.0)	3.350 (85.1)	1	340	B30-R10000
B30-260-7569-CLP4B	B-7569	Vinyl		2.170 (55.0)	3.350 (85.1)	1	340	B30-R10000
B30-261-569-CLP4B	B-569	Polyester		2.950 (75.0)	4.330 (110.0)	1	270	B30-R10000
B30-261-7569-CLP4B	B-7569	Vinyl		2.950 (75.0)	4.330 (110.0)	1	270	B30-R10000
B30-262-569-CLP4B	B-569	Polyester		4.130 (105.0)	6.100 (155.0)	1	200	B30-R10000
B30-262-7569-CLP4B	B-7569	Vinyl		4.130 (105.0)	6.100 (155.0)	1	200	B30-R10000
B30-18-7569-CLP4C	B-7569	Vinyl		1.000 (25.4)	3.000 (76.2)	1	1000	B30-R10000

### ▶ Easily create your GHS labels with Brady Workstation GHS App

- Use built-in pre-formatted label layouts with approved GHS symbols
- Search the built-in chemical database by CAS number to auto-populate your label, then edit to meet your specific SDS
- Print any of the six template sizes
- No driver required when using the BradyPrinter i5300



All part numbers above are compatible with BradyPrinter i3300, i5300, S3000, S3100, and BBP30, 31, 33, 35, 37 models. Visit [BradyID.com](http://BradyID.com) to confirm compatibility.



## General Identification Die Cut Labels for Bins, Shelves, Tools and Production Areas (B-439, B-498, B-499, B-595)

- These labels are all highly conforming to irregular, angled or rough surfaces frequently found in industrial production line areas
- Die-cut labels are an ideal choice when pre-cut labels are preferred or consistent label sizing is required
- B-595 is a convenient cut-to-length continuous material that reduces the need to stock multiple parts when inconsistent label lengths are expected

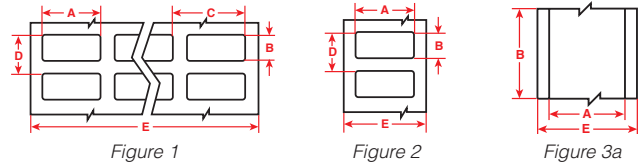

For Use with Printers:	Diagram	Catalog #	Color	Label width A inch (mm)	Label height B inch (mm)	Horiz. repeat C inch (mm)	Vert. repeat D inch (mm)	Web width E inch (mm)	Labels per row	Labels per roll	Rec. ribbon
<b>Vinyl - Highly pliable and conforming with aggressive permanent adhesive and excellent chemical resistance (B-439)</b>											
i3300, i5300, BBP33	Fig. 1	B33-5-439	White	1.000 (25.4)	0.500 (12.7)	1.075 (27.3)	0.600 (15.2)	3.350 (85.1)	3	7000	B30-R6000
i3300, i5300, BBP33	Fig. 1	B33-37-439	White	1.500 (38.1)	0.500 (12.7)	1.650 (41.9)	0.600 (15.2)	3.350 (85.1)	2	5000	B30-R6000
i3300, i5300, BBP33	Fig. 2	B33-53-439	White	2.000 (50.8)	0.500 (12.7)	-	0.600 (15.2)	2.200 (55.9)	1	2500	B30-R6000
i3300, i5300, BBP33	Fig. 2	B33-17-439	White	2.000 (50.8)	1.000 (25.4)	-	1.125 (28.5)	2.200 (55.9)	1	1000	B30-R6000
i3300, i5300, BBP33	Fig. 2	B33-18-439	White	3.000 (76.2)	1.000 (25.4)	-	1.125 (28.5)	3.350 (85.1)	1	1000	B30-R6000
i3300, i5300, BBP33	Fig. 2	B33-19-439	White	3.000 (76.2)	2.000 (50.8)	-	2.125 (53.9)	3.200 (81.3)	1	700	B30-R6000
i3300, i5300, BBP33	Fig. 2	B33-55-439	White	4.000 (101.6)	2.000 (50.8)	-	2.125 (53.9)	4.200 (106.7)	1	700	B30-R6000
i3300, i5300, BBP33	Fig. 2	B33-76-439	White	4.000 (101.6)	3.000 (76.2)	-	3.125 (79.3)	4.200 (106.7)	1	500	B30-R6000
<b>Flexible Vinyl Cloth - Pliable with aggressive hold adhesive that can be removed and reapplied (B-498)</b>											
i3300, i5300, BBP33	Fig. 1	B33-68-498	White	0.500 (12.7)	0.750 (19.1)	0.600 (15.2)	0.875 (22.2)	2.500 (63.5)	4	5000	B30-R6200
i3300, i5300, BBP33	Fig. 1	B33-87-498	White	0.500 (12.7)	1.437 (36.5)	0.600 (15.2)	1.562 (39.7)	3.700 (94.0)	6	2500	B30-R6200
i3300, i5300, BBP33	Fig. 1	B33-5-498	White	1.000 (25.4)	0.500 (12.7)	1.075 (27.3)	0.600 (15.2)	3.350 (85.1)	3	5000	B30-R6200
i3300, i5300, BBP33	Fig. 1	B33-88-498	White	1.000 (25.4)	0.750 (19.1)	1.100 (27.9)	0.875 (22.2)	2.300 (58.4)	2	2500	B30-R6200
i3300, i5300, BBP33	Fig. 1	B33-89-498	White	1.000 (25.4)	1.437 (36.5)	1.100 (27.9)	1.562 (39.7)	3.400 (86.4)	3	2300	B30-R6200
<b>Flexible Nylon Cloth - Permanent adhesive (B-499)</b>											
i3300, i5300, BBP33	Fig. 1	B33-68-499	White	0.500 (12.7)	0.750 (19.1)	0.600 (15.2)	0.875 (22.2)	2.500 (63.5)	4	1500	B30-R6000
i3300, i5300, BBP33	Fig. 1	B33-165-499	White	0.800 (20.3)	1.437 (36.5)	0.900 (22.9)	1.562 (39.7)	3.700 (94.0)	4	2500	B30-R6000
i3300, i5300, BBP33	Fig. 1	B33-5-499	White	1.000 (25.4)	0.500 (12.7)	1.075 (27.3)	0.600 (15.2)	3.350 (85.1)	3	5000	B30-R6000
i3300, i5300, BBP33	Fig. 1	B33-88-499	White	1.000 (25.4)	0.750 (19.1)	1.100 (27.9)	0.875 (22.2)	2.300 (58.4)	2	2500	B30-R6000
i3300, i5300, BBP33	Fig. 2	B33-136-499	White	1.500 (38.1)	0.750 (19.1)	-	0.875 (22.2)	1.770 (45.0)	1	1500	B30-R6000
i3300, i5300, BBP33	Fig. 2	B33-137-499	White	2.000 (50.8)	1.000 (25.4)	-	1.125 (28.6)	2.200 (55.9)	1	1100	B30-R6000
<b>Glossy Polyester - Ultra-aggressive adhesive for flat but highly textured surfaces (B-483)</b>											
i3300, i5300, BBP33	Fig. 1	B33-149-483	Gloss White	0.500 (12.7)	0.500 (12.7)	0.600 (15.2)	0.600 (15.2)	2.500 (63.5)	4	5000	B30-R6000
i3300, i5300, BBP33	Fig. 1	B33-5-483	Gloss White	1.000 (25.4)	0.500 (12.7)	1.075 (27.3)	0.600 (15.2)	3.350 (85.1)	3	5000	B30-R6000
i3300, i5300, BBP33	Fig. 2	B33-17-483	Gloss White	2.000 (50.8)	1.000 (25.4)	-	1.125 (28.6)	2.200 (55.9)	1	1500	B30-R6000
i3300, i5300, BBP33	Fig. 2	B33-7-483	Gloss White	2.750 (69.9)	1.250 (31.8)	-	1.375 (34.9)	2.950 (74.9)	1	1000	B30-R6000
i3300, i5300, BBP33	Fig. 2	B33-18-483	Gloss White	3.000 (76.2)	1.000 (25.4)	-	1.125 (28.6)	3.200 (81.3)	1	1500	B30-R6000
i3300, i5300, BBP33	Fig. 2	B33-19-483	Gloss White	3.000 (76.2)	2.000 (50.8)	-	2.125 (54.0)	3.200 (81.3)	1	500	B30-R6000
i3300, i5300, BBP33	Fig. 2	B33-55-483	Gloss White	4.000 (101.6)	2.000 (50.8)	-	2.125 (54.0)	4.200 (106.7)	1	750	B30-R6000
<b>Cut-to-Length Vinyl - Highly pliable all weather with aggressive permanent adhesive (B-595)</b>											
i3300, i5300, S3000, S3100, BBP30, BBP31, BBP33, BBP35, BBP37	Fig. 3a	B30C-500-595-WT	White	0.500 (12.7)	100 ft. (30.5 m)	-	-	0.700 (17.8)	1 roll (cont.)		B30-R10000
i3300, i5300, S3000, S3100, BBP30, BBP31, BBP33, BBP35, BBP37	Fig. 3a	B30C-1125-595-WT	White	1.125 (28.6)	100 ft. (30.5 m)	-	-	1.375 (34.9)	1 roll (cont.)		B30-R10000
i3300, i5300, S3000, S3100, BBP30, BBP31, BBP33, BBP35, BBP37	Fig. 3a	B30C-500-595-YL	Yellow	0.500 (12.7)	100 ft. (30.5 m)	-	-	0.700 (17.8)	1 roll (cont.)		B30-R10000
i3300, i5300, S3000, S3100, BBP30, BBP31, BBP33, BBP35, BBP37	Fig. 3a	B30C-1125-595-YL	Yellow	1.125 (28.6)	100 ft. (30.5 m)	-	-	1.375 (34.9)	1 roll (cont.)		B30-R10000

## ToughStripe® Printable Floor Marking Tape (B-483A with overlamine)

- Revolutionary B-483A material has ultra-aggressive adhesive
- Withstands forklift and pallet jack traffic without tearing or lifting
- Each roll ships with a roll of clear overlamine which must be applied over printed label and onto appropriate surface for best performance

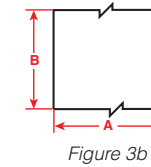
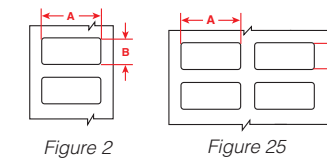

Diagram	Catalog #	B#	Color	Label Width A Inch (mm)	Roll Length B Feet (m)	Labels Per Roll	Rec. Ribbon
Fig. 3b	B30C-1125-483WT-KT	B-483	White	1.125 (28.6)	100 (30.5)	1 roll (cont.)	B30-R6000
Fig. 3b	B30C-2250-483WT-KT	B-483	White	2.250 (57.5)	100 (30.5)	1 roll (cont.)	B30-R6000
Fig. 3b	B30C-3000-483WT-KT	B-483	White	3.000 (76.2)	100 (30.5)	1 roll (cont.)	B30-R6000
Fig. 3b	B30C-4000-483WT-KT	B-483	White	4.000 (101.6)	100 (30.5)	1 roll (cont.)	B30-R6000
Fig. 3b	B30C-1125-483YL-KT	B-483	Yellow	1.125 (28.6)	100 (30.5)	1 roll (cont.)	B30-R6000
Fig. 3b	B30C-2250-483YL-KT	B-483	Yellow	2.250 (57.5)	100 (30.5)	1 roll (cont.)	B30-R6000
Fig. 3b	B30C-3000-483YL-KT	B-483	Yellow	3.000 (76.2)	100 (30.5)	1 roll (cont.)	B30-R6000
Fig. 3b	B30C-4000-483YL-KT	B-483	Yellow	4.000 (101.6)	100 (30.5)	1 roll (cont.)	B30-R6000
Fig. 3b	B30C-1125-483RD-KT	B-483	Red	1.125 (28.6)	100 (30.5)	1 roll (cont.)	B30-R4400-WT
Fig. 3b	B30C-2250-483RD-KT	B-483	Red	2.250 (57.5)	100 (30.5)	1 roll (cont.)	B30-R4400-WT
Fig. 3b	B30C-4000-483RD-KT	B-483	Red	4.000 (101.6)	100 (30.5)	1 roll (cont.)	B30-R4400-WT
Fig. 3b	B30C-1125-483BL-KT	B-483	Blue	1.125 (28.6)	100 (30.5)	1 roll (cont.)	B30-R4400-WT
Fig. 3b	B30C-2250-483BL-KT	B-483	Blue	2.250 (57.5)	100 (30.5)	1 roll (cont.)	B30-R4400-WT
Fig. 3b	B30C-4000-483BL-KT	B-483	Blue	4.000 (101.6)	100 (30.5)	1 roll (cont.)	B30-R4400-WT
Fig. 3b	B30C-1125-483GN-KT	B-483	Green	1.125 (28.6)	100 (30.5)	1 roll (cont.)	B30-R4400-WT
Fig. 3b	B30C-2250-483GN-KT	B-483	Green	2.250 (57.5)	100 (30.5)	1 roll (cont.)	B30-R4400-WT
Fig. 3b	B30C-4000-483GN-KT	B-483	Green	4.000 (101.6)	100 (30.5)	1 roll (cont.)	B30-R4400-WT
Fig. 3b	B30C-1125-483BK-KT	B-483	Black	1.125 (28.6)	100 (30.5)	1 roll (cont.)	B30-R4400-WT
Fig. 3b	B30C-2250-483BK-KT	B-483	Black	2.250 (57.5)	100 (30.5)	1 roll (cont.)	B30-R4400-WT
Fig. 3b	B30C-4000-483BK-KT	B-483	Black	4.000 (101.6)	100 (30.5)	1 roll (cont.)	B30-R4400-WT
Fig. 3b	B30C-1125-483OR-KT	B-483	Orange	1.125 (28.6)	100 (30.5)	1 roll (cont.)	B30-R6000
Fig. 3b	B30C-2250-483OR-KT	B-483	Orange	2.250 (57.5)	100 (30.5)	1 roll (cont.)	B30-R6000
Fig. 3b	B30C-4000-483OR-KT	B-483	Orange	4.000 (101.6)	100 (30.5)	1 roll (cont.)	B30-R6000

ToughStripe part numbers above are compatible with BradyPrinter i3300, i5300, BradyPrinter S3000, BradyPrinter S3100, and BBP®35 and BBP®37 printers. ToughStripe material is not compatible with BBP®30, BBP®33 and BBP®31 printers.

## Microscope Slide Labels (B-481)

- Designed specifically to identify slides and to resist exposure to harsh chemicals during the slide-staining process
- Performs well in stains such as hematoxylin and eosin
- Extreme chemical resistance withstands the rigors of typical deparaffinization, including ethanol, xylene and H&E staining processes



For Use with Printers:	Diagram	Catalog #	B#	Color	Label Width A Inch (mm)	Label Height B Inch (mm)	Labels Per Row	Labels Per Roll	Rec. Ribbon
i3300, i5300, BBP33	Fig. 2	B33-194-481	B-481	White	0.900 (22.9)	0.750 (19.1)	1	2000	B30-R6400
i3300, i5300, BBP33	Fig. 25	B33-141-481	B-481	White	0.900 (22.9)	0.900 (22.9)	2	1500	B30-R6400
i3300, i5300, BBP33	Fig. 2	B33-195-481	B-481	White	0.900 (22.9)	0.375 (9.5)	1	3000	B30-R6400

## Cryogenic Tube and Vial Labels (B-461, B-490, B-492, B-7425)

FreezerBondz™ labels can be applied to room temperature or already frozen samples, with a small overlap. The label remains legible and will stick to the tube during processing, even when immersed in liquid or vapor phase nitrogen and ultra-low temperature freezer storage.

- **B-461 Self-Laminating Polyester:** Ultra-thin polyester label with clear overlaminated tail that protects print and allows liquid levels to be visible
- **B-490 Polyester:** White FreezerBondz label ideal for flat frozen surfaces. Adheres to frozen tubes and vials when wrapped around itself by at least 1/8 in.
- **B-492 Polyester:** FreezerBondz ultra-thin white polyester label for labeling of frosted/frozen or room temperature vials, tubes and canes. Superior chemical and abrasion resistance
- **B-7425 Polypropylene:** Ideal for labeling dry, room temperature specimen containers. Material withstands temperature ranges from -320° to 248° F (-196° to 121° C). Chemical resistance to ethanol, DMSO, IPS, short-term xylene, 10% formalin, 50% acetic acid and toluene

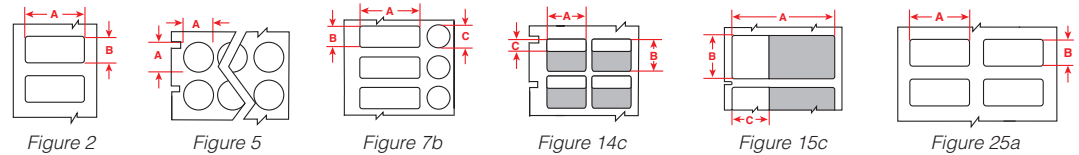

For Use with Printers:	Diagram	Catalog #	B#	Color	Label Width A Inch (mm)	Label Height B Inch (mm)	Print-On Height C Inch (mm)	Labels Per Row	Labels Per Roll	Rec. Ribbon
<b>Self-Laminating Polyester (B-461):</b>										
i3300, i5300, BBP33	Fig. 15c	B33-127-461	B-461	White/Clear	0.500 (12.7)	2.200 (55.9)	0.750 (19.1)	1	1500	B30-R4300
i3300, i5300, BBP33	Fig. 15c	B33-133-461	B-461	White/Clear	0.600 (15.2)	1.625 (41.3)	1.000 (25.4)	1	1500	B30-R4300
i3300, i5300, BBP33	Fig. 14c	B33-139-461	B-461	White/Clear	1.000 (25.4)	5.250 (133.4)	1.500 (38.1)	2	650	B30-R4300
i3300, i5300, BBP33	Fig. 15c	B33-123-461	B-461	White/Clear	1.800 (45.7)	0.375 (9.5)	0.750 (19.1)	1	1500	B30-R4300
i3300, i5300, BBP33	Fig. 15c	B33-122-461	B-461	White/Clear	1.800 (45.7)	0.500 (12.7)	0.750 (19.1)	1	1500	B30-R4300
i3300, i5300, BBP33	Fig. 14c	B33-276-461	B-461	White/Clear	2.625 (66.7)	1.000 (25.4)	1.000 (25.4)	1	1500	B30-R4300
i3300, i5300, BBP33	Fig. 15c	B33-134-461	B-461	White/Clear	3.500 (88.9)	1.500 (38.1)	1.250 (31.8)	1	1000	B30-R4300
<b>Polyester (B-490):</b>										
i3300, i5300, BBP33	Fig. 7b	B33-126-490	B-490	White	0.900 (22.9)	0.500 (12.7)	0.500 (12.7) dia.	1	2500	B30-R4300
i3300, i5300, BBP33	Fig. 2	B33-154-490	B-490	White	1.250 (31.8)	0.375 (9.5)	-	1	1500	B30-R4300
i3300, i5300, BBP33	Fig. 2	B33-155-490	B-490	White	1.625 (41.3)	0.600 (15.2)	-	1	1500	B30-R4300
i3300, i5300, BBP33	Fig. 2	B33-156-490	B-490	White	1.900 (48.2)	1.000 (25.4)	-	1	1500	B30-R4300
i3300, i5300, BBP33	Fig. 2	B33-157-490	B-490	White	2.200 (55.9)	1.500 (38.1)	-	1	1000	B30-R4300
i3300, i5300, BBP33	Fig. 2	B33-158-490	B-490	White	3.750 (95.3)	1.750 (44.4)	-	1	1100	B30-R4300
<b>Polyester (B-492):</b>										
i3300, i5300, BBP33	Fig. 5	B33-143-492	B-492	White	0.375 (9.5) dia.	-	-	4	1500	B30-R6400
i3300, i5300, BBP33	Fig. 7b	B33-182-492	B-492	White	0.500 (12.7)	1.000 (25.4)	0.44 (11.17) dia.	1	1500	B30-R6400
i3300, i5300, BBP33	Fig. 2	B33-180-492	B-492	White	0.900 (22.9)	1.000 (25.4)	-	1	1500	B30-R6400
i3300, i5300, BBP33	Fig. 25a	B33-152-492	B-492	White	1.000 (25.4)	0.375 (9.5)	-	2	2500	B30-R6400
i3300, i5300, BBP33	Fig. 7b	B33-163-492	B-492	White	1.000 (25.4)	0.375 (9.5)	0.375 (9.5) dia.	1	1500 sets	B30-R6400
i3300, i5300, BBP33	Fig. 7b	B33-181-492	B-492	White	1.000 (25.4)	0.500 (12.7)	0.375 (9.5) dia.	1	1500 sets	B30-R6400
i3300, i5300, BBP33	Fig. 2	B33-59-492	B-492	White	1.000 (25.4)	0.500 (12.7)	-	1	2500	B30-R6400
i3300, i5300, BBP33	Fig. 2	B33-179-492	B-492	White	1.000 (25.4)	1.000 (25.4)	-	1	1900	B30-R6400
i3300, i5300, BBP33	Fig. 2	B33-156-492	B-492	White	1.900 (48.3)	1.000 (25.4)	-	1	1500	B30-R6400
<b>Polypropylene (B-7425):</b>										
i3300, i5300, BBP33	Fig. 2	B33-257-7425	B-7425	White	0.825 (21.0)	0.250 (6.4)	-	1	1500	B30-R4300
i3300, i5300, BBP33	Fig. 25a	B33-152-7425	B-7425	White	1.000 (25.4)	0.375 (9.5)	-	2	2000	B30-R4300
i3300, i5300, BBP33	Fig. 2	B33-59-7425	B-7425	White	1.000 (25.4)	0.500 (12.7)	-	1	2000	B30-R4300
i3300, i5300, BBP33	Fig. 25a	B33-88-7425	B-7425	White	1.000 (25.4)	0.750 (19.1)	-	2	2000	B30-R4300
i3300, i5300, BBP33	Fig. 2	B33-256-7425	B-7425	White	1.300 (33.0)	0.600 (15.2)	-	1	1500	B30-R4300
i3300, i5300, BBP33	Fig. 25a	B33-37-7425	B-7425	White	1.500 (38.1)	0.500 (12.7)	-	2	1500	B30-R4300

## Centrifuge and PCR Tube Labels (B-499, B-7425)

Designed with ultra-thin material that prevents vials from jamming in centrifuges or racks, these labels withstand harsh temperatures and chemicals without falling off, fading or smearing.

- **B-499 Nylon Cloth:** Thick white nylon cloth for easy handling and conformability
- **B-7425 Polypropylene:** Moderate chemical resistance, ideal for labeling dry, room-temperature specimen containers that withstand temperature ranges from -320° to 248° F (-196° to 121° C). Chemical resistance to ethanol, DMSO, IPS, short-term xylene, 10% formalin, 50% acetic acid and toluene

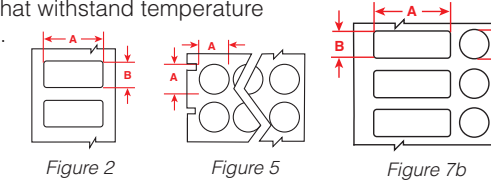

For Use with Printers:	Diagram	Catalog #	B#	Color	Label Width A Inch (mm)	Label Height B Inch (mm)	Vial Top Dia. C Inch (mm)	Labels Per Row	Labels Per Roll	Rec. Ribbon
<b>Nylon Cloth (B-499):</b>										
i3300, i5300, BBP33	Fig. 5	B33-143-499	B-499	White	0.375 (9.5)	-	-	4	1500	B30-R6000
i3300, i5300, BBP33	Fig. 5	B33-144-499	B-499	White	0.500 (12.7)	-	-	3	1500	B30-R6000
<b>Polypropylene (B-7425):</b>										
i3300, i5300, BBP33	Fig. 2	B33-257-7425	B-7425	White	0.825 (21.0)	0.250 (6.4)	-	1	1500	B30-R4300
i3300, i5300, BBP33	Fig. 2	B33-152-7425	B-7425	White	1.000 (25.4)	0.375 (9.5)	-	2	2000	B30-R4300
i3300, i5300, BBP33	Fig. 7b	B33-249-7425	B-7425	White	1.000 (25.4)	0.375 (9.5)	0.375 (9.5) dia.	1	1500	B30-R4300
i3300, i5300, BBP33	Fig. 2	B33-59-7425	B-7425	White	1.000 (25.4)	0.500 (12.7)	-	1	2000	B30-R4300
i3300, i5300, BBP33	Fig. 7b	B33-251-7425	B-7425	White	1.000 (25.4)	0.500 (12.7)	0.440 (11.1) dia.	1	1500	B30-R4300
i3300, i5300, BBP33	Fig. 2	B33-179-7425	B-7425	White	1.000 (25.4)	1.000 (25.4)	-	1	1500	B30-R4300
i3300, i5300, BBP33	Fig. 2	B33-256-7425	B-7425	White	1.300 (33.0)	0.600 (15.2)	-	1	1500	B30-R4300
i3300, i5300, BBP33	Fig. 2	B33-37-7425	B-7425	White	1.500 (38.1)	0.500 (12.7)	-	2	1500	B30-R4300
i3300, i5300, BBP33	Fig. 2	B33-136-7425	B-7425	White	1.500 (38.1)	0.750 (19.1)	-	1	1500	B30-R4300
i3300, i5300, BBP33	Fig. 2	B33-258-7425	B-7425	White	1.500 (38.1)	1.750 (44.5)	-	1	900	B30-R4300
i3300, i5300, BBP33	Fig. 2	B33-137-7425	B-7425	White	2.000 (50.8)	1.000 (25.4)	-	1	1500	B30-R4300

## Color-Stripe Polyester Lab Labels (B-494)

White labels with preprinted color borders for color-coding samples. Ultra-thin material that prevents vials from jamming in centrifuges or racks, these labels withstand harsh temperatures and chemicals without falling off, fading or smearing. The colored boarder is non-printable, but the colored vial top is printable.

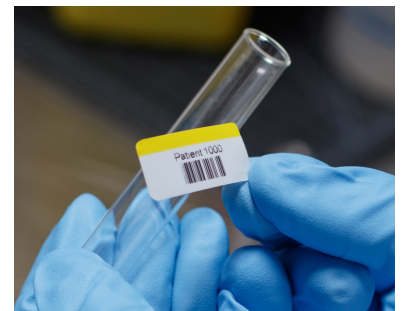
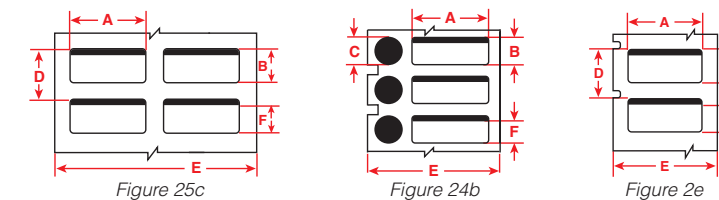

For Use with Printers:	Diagram	Catalog #	Border Color	Label width A inch (mm)	Label height B inch (mm)	Print-On Height C inch (mm)	Print-On Height F inch (mm)	Labels per row	Labels per roll	Rec. ribbon
i3300, i5300, BBP33	Fig. 25c	B33-152-494-BL	Blue	1.000 (25.4)	0.375 (9.5)	-	0.250 (6.4)	2	1,500	B30-R6400
i3300, i5300, BBP33	Fig. 25c	B33-152-494-GN	Green	1.000 (25.4)	0.375 (9.5)	-	0.250 (6.4)	2	1,500	B30-R6400
i3300, i5300, BBP33	Fig. 25c	B33-152-494-OR	Orange	1.000 (25.4)	0.375 (9.5)	-	0.250 (6.4)	2	1,500	B30-R6400
i3300, i5300, BBP33	Fig. 25c	B33-152-494-PK	Pink	1.000 (25.4)	0.375 (9.5)	-	0.250 (6.4)	2	1,500	B30-R6400
i3300, i5300, BBP33	Fig. 25c	B33-152-494-RD	Red	1.000 (25.4)	0.375 (9.5)	-	0.250 (6.4)	2	1,500	B30-R6400
i3300, i5300, BBP33	Fig. 25c	B33-152-494-YL	Yellow	1.000 (25.4)	0.375 (9.5)	-	0.250 (6.4)	2	1,500	B30-R6400
i3300, i5300, BBP33	Fig. 24b	B33-250-494-BL	Blue	1.000 (25.4)	0.500 (12.7)	0.375 (9.5) dia.	0.375 (9.5)	1	1,500	B30-R6400
i3300, i5300, BBP33	Fig. 24b	B33-250-494-GN	Green	1.000 (25.4)	0.500 (12.7)	0.375 (9.5) dia.	0.375 (9.5)	1	1,500	B30-R6400
i3300, i5300, BBP33	Fig. 24b	B33-250-494-OR	Orange	1.000 (25.4)	0.500 (12.7)	0.375 (9.5) dia.	0.375 (9.5)	1	1,500	B30-R6400
i3300, i5300, BBP33	Fig. 24b	B33-250-494-PK	Pink	1.000 (25.4)	0.500 (12.7)	0.375 (9.5) dia.	0.375 (9.5)	1	1,500	B30-R6400
i3300, i5300, BBP33	Fig. 24b	B33-250-494-RD	Red	1.000 (25.4)	0.500 (12.7)	0.375 (9.5) dia.	0.375 (9.5)	1	1,500	B30-R6400
i3300, i5300, BBP33	Fig. 24b	B33-250-494-YL	Yellow	1.000 (25.4)	0.500 (12.7)	0.375 (9.5) dia.	0.375 (9.5)	1	1,500	B30-R6400
i3300, i5300, BBP33	Fig. 2e	B33-179-494-BL	Blue	1.000 (25.4)	1.000 (25.4)	-	0.875 (22.2)	1	1,500	B30-R6400
i3300, i5300, BBP33	Fig. 2e	B33-179-494-GN	Green	1.000 (25.4)	1.000 (25.4)	-	0.875 (22.2)	1	1,500	B30-R6400
i3300, i5300, BBP33	Fig. 2e	B33-179-494-OR	Orange	1.000 (25.4)	1.000 (25.4)	-	0.875 (22.2)	1	1,500	B30-R6400
i3300, i5300, BBP33	Fig. 2e	B33-179-494-PK	Pink	1.000 (25.4)	1.000 (25.4)	-	0.875 (22.2)	1	1,500	B30-R6400
i3300, i5300, BBP33	Fig. 2e	B33-179-494-RD	Red	1.000 (25.4)	1.000 (25.4)	-	0.875 (22.2)	1	1,500	B30-R6400
i3300, i5300, BBP33	Fig. 2e	B33-179-494-YL	Yellow	1.000 (25.4)	1.000 (25.4)	-	0.875 (22.2)	1	1,500	B30-R6400

## Dissolvable Paper Labels (B-403)

- Designed for temporary applications where easy removal, re-identification or waste reduction are valued
- Ideal for labeling vials, tubes or general glassware, temporary asset tracking, animal housing identification, and general use
- Completely dissolves in warm water within 30 seconds, leaving no adhesive residue

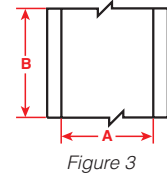

For Use with Printers:	Diagram	Catalog #	B#	Color	Label Width A Inch (mm)	Roll Length B Inch (mm)	Labels Per Roll	Rec. Ribbon
i3300, i5300, BBP33	Fig. 3	B30C-1125-403-WT	B-403	White	1.125 (28.575)	100 (30.5)	1 (cont.)	B30-R4300
i3300, i5300, BBP33	Fig. 3	B30C-2250-403-WT	B-403	White	2.250 (57.15)	100 (30.5)	1 (cont.)	B30-R4300
i3300, i5300, BBP33	Fig. 3	B30C-3000-403-WT	B-403	White	3.000 (76.2)	100 (30.5)	1 (cont.)	B30-R4300
i3300, i5300, BBP33	Fig. 3	B30C-4000-403-WT	B-403	White	4.000 (101.6)	100 (30.5)	1 (cont.)	B30-R4300

## Sterilization Indicating Labels (B-7425-AC)

- Specially designed with a pre-printed "sterilized" header that indicates steam sterilization with a color-changing pre-printed header when autoclaved at 250.7° F (121.5° C) for 10 minutes
- Withstands temperature ranges from -320° to 248° F (-196° to 121° C)
- For use in LN2, freezers, autoclave and hot water baths
- Chemical resistance to ethanol, DMSO, IPS, short-term xylene, 10% formalin, 50% acetic acid and toluene

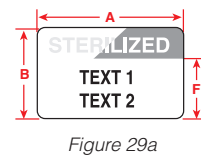

For Use with Printers:	Diagram	Catalog #	B#	Color	Label Width A Inch (mm)	Label Height B Inch (mm)	Print Area Height F Inch (mm)	Labels Per Row	Labels Per Roll	Rec. Ribbon
i3300, i5300, BBP33	Fig. 29a	B33-235-7425-AC	B-7425-AC	White	1.500 (38.1)	1.000 (25.4) *	0.750 (19.1)	1	1250	B30-R4300
i3300, i5300, BBP33	Fig. 29a	B33-137-7425-AC	B-7425-AC	White	2.000 (50.8)	1.000 (25.4) *	0.750 (19.1)	1	1500	B30-R4300

## Tissue Cassette Labels (B-481)

- White polyester label with superior resistance to tissue processing chemicals and embedding procedures. Use with the BSP™31 Label Attachment system for pre-process tissue cassette identification

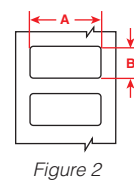

For Use with Printers:	Diagram	Catalog #	B#	Color	Label Width A Inch (mm)	Label Height B Inch (mm)	Labels Per Row	Labels Per Roll	Rec. Ribbon
i3300, i5300, BBP33	Fig. 2	B33-199-481	B-481	White	1.050 (26.7)	0.250 (6.4)	1	3000	B30-R6400
i3300, i5300, BBP33	Fig. 2	B33-213-481	B-481	White	1.050 (26.7)	0.313 (8)	1	3000	B30-R6400

## General Identification for Laboratory Storage, Equipment and Safety Labels (B-499, B-595, B-7569)

- Super strong adhesives and colors ideal for marking laboratory equipment, containers, hoses and lab storage cabinets, shelves and drawers
- GHS labels available for marking chemicals in the lab and shipment boxes when collaborating with other labs
- Pre-printed sign header labels make your safety and housekeeping reminders stand out and stay put!

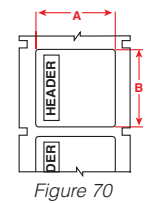
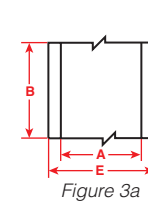
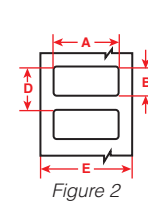
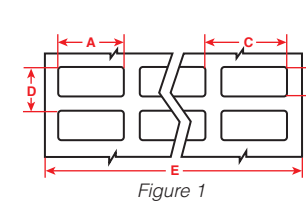

Diagram	Catalog #	Color / Legend	Label Width A Inch (mm)	Label Height B Inch (mm)	Horiz. Repeat C Inch (mm)	Vert. Repeat D Inch (mm)	Web Width E Inch (mm)	Roll Length B Feet (m)	Labels Per Row	Labels Per Roll	Rec. Ribbon
<b>Nylon Cloth - Permanent Adhesive (B-499):</b>											
Fig. 1	B33-68-499	White	0.500 (12.7)	0.750 (19.1)	0.600 (15.2)	0.875 (22.2)	2.500 (63.5)	-	4	1500	B30-R6000
Fig. 1	B33-165-499	White	0.800 (20.3)	1.437 (36.5)	0.900 (22.9)	1.562 (39.7)	3.700 (94.0)	-	4	2500	B30-R6000
Fig. 2	B33-125-499	White	0.900 (22.9)	0.500 (12.7)	-	-	-	-	1	1500	B30-R6000
Fig. 1	B33-126-499	White	0.900 (22.9)	0.500 (12.7)	-	-	-	-	2	1500	B30-R6000
Fig. 2	B33-163-499	White	1.000 (25.4)	0.375 (9.5)	-	-	-	-	1	1500	B30-R6000
Fig. 1	B33-152-499	White	1.000 (25.4)	0.375 (9.5)	-	-	-	-	2	1500	B30-R6000
Fig. 2	B33-136-499	White	1.500 (38.1)	0.750 (19.1)	-	0.875 (22.2)	1.770 (45.0)	-	1	1500	B30-R6000
Fig. 2	B33-137-499	White	2.000 (50.8)	1.000 (25.4)	-	1.125 (28.6)	2.200 (55.9)	-	1	1100	B30-R6000
<b>Indoor/Outdoor Vinyl (B-595):</b>											
Fig. 3a	B30C-500-595-WT	White	0.500 (12.7)	-	-	-	-	100 (30.5)	-	1 roll (cont.)	B30-R10000
Fig. 3a	B30C-1125-595-WT	White	1.125 (28.6)	-	-	-	-	100 (30.5)	-	1 roll (cont.)	B30-R10000
Fig. 3a	B30C-500-595-YL	Yellow	0.500 (12.7)	-	-	-	-	100 (30.5)	-	1 roll (cont.)	B30-R10000
Fig. 3a	B30C-1125-595-YL	Yellow	1.125 (28.6)	-	-	-	-	100 (30.5)	-	1 roll (cont.)	B30-R10000
Fig. 3a	B30C-500-595-RD	Red	0.500 (12.7)	-	-	-	-	100 (30.5)	-	1 roll (cont.)	B30-R10000-WT
Fig. 3a	B30C-1125-595-RD	Red	1.125 (28.6)	-	-	-	-	100 (30.5)	-	1 roll (cont.)	B30-R10000-WT
Fig. 3a	B30C-500-595-BL	Blue	0.500 (12.7)	-	-	-	-	100 (30.5)	-	1 roll (cont.)	B30-R10000-WT
Fig. 3a	B30C-1125-595-BL	Blue	1.125 (28.6)	-	-	-	-	100 (30.5)	-	1 roll (cont.)	B30-R10000-WT
Fig. 3a	B30C-500-595-GN	Green	0.500 (12.7)	-	-	-	-	100 (30.5)	-	1 roll (cont.)	B30-R10000-WT
Fig. 3a	B30C-1125-595-GN	Green	1.125 (28.6)	-	-	-	-	100 (30.5)	-	1 roll (cont.)	B30-R10000-WT
<b>Pre-Printed Pre-Cut Blank Sign Headers (B-595):</b>											
Fig. 70	B30-241-595-ANSIDA	<b>▲ DANGER</b>	2.250 (57.5)	3.000 (76.2)	-	-	-	-	1	300	B30-R10000
Fig. 70	B30-25-595-ANSIDA		4.000 (101.6)	6.000 (152.4)	-	-	-	-	1	175	B30-R10000
Fig. 70	B30-241-595-ANSINO	<b>NOTICE</b>	2.250 (57.5)	3.000 (76.2)	-	-	-	-	1	300	B30-R10000
Fig. 70	B30-25-595-ANSINO		4.000 (101.6)	6.000 (152.4)	-	-	-	-	1	175	B30-R10000
<b>Pre-Printed GHS/CLP Chemical (B-7569):</b>											
L4B Diamond + Text	B30-260-7569-CLP4B		2.170 (55.0)	3.350 (85.1)	-	-	-	-	1	340	B30-R10000
	B30-261-7569-CLP4B		2.950 (75.0)	4.330 (110.0)	-	-	-	-	1	270	B30-R10000
L4C Diamond + Text	B30-18-7569-CLP4C		1.000 (25.4)	3.000 (76.2)	-	-	-	-	1	1000	B30-R10000

(B-595) U.S. Patent Nos. 5,823,689; 6,570,602. Additional Patents Pending.

All part numbers above are compatible with BradyPrinter i3300, i5300, and BBP33. Parts may also be compatible with BradyPrinter S3000, BradyPrinter S3100, BBP30, BBP31, BBP35 and BBP37 printers. Visit BradyID.com to confirm compatibility.

# Printer Specifications

Model(s):	
Model name	BradyPrinter i5300 Industrial Label Printer
Media alignment	Center justified
Volume guidelines*	5,000+ labels per day, 5 days per week
Printhead / Printing Characteristics:	
Print resolution	300 dpi model 600 dpi model
Minimum font size	300 dpi; 4pt / 600 dpi; 3pt (heat, speed, font, material dependent)
Print method	Thermal transfer, direct transfer
Cutter type / Auto cutter	Auto cutter built-in (all models)
Print color capability	Single color
Print speed	up to 7 in. / sec – die cuts (300 dpi) up to 10 in. / sec – continuous (300 dpi) up to 3 in. / sec – die cuts (600 dpi) up to 5 in. / sec – continuous (600 dpi)
Print width (max, cross-web)	4.015 in.
Print length (max, down-web)	5.0 ft.
Print job interrupt options	Resume print job where pause or interruption occurs, or select specific label in job
Printhead replacement	Field replaceable (with same dpi only)
Print roller replacement	Field replaceable (T10 wrench required)
Print on demand	Yes
Print pause	Yes
Print job list on stand-alone printer	Yes - BradyWorkstation print jobs can be saved to printer for later on-printer selection and placement into a print queue. This function also write-protects the print jobs from unwanted editing.
Interface:	
Display type	Color LCD touchscreen
Display size (diagonal)	7.0 in.
Display resolution (H x W)	600 x 1024 pixels
Display languages	Bahasa Indonesia, Bahasa Melayu, Bulgarian, Chinese (simplified), Chinese (traditional), Croatian, Czech, Danish, Dutch, Estonian, Finnish, French, German, Hungarian, Italian, Japanese, Korean, Norwegian, Polish, Portuguese, Romanian, Russian, Slovakian, Slovenian, Spanish, Swedish, Turkish, Thai, Vietnamese
Display status bar	Installed ribbon and label part numbers, amount of supplies remaining, Wi-Fi connection, Bluetooth connection, receiving data icon, ready state / error state
Media Characteristics:	
Label width (cross-web)	0.25 in. to 4.25 in. (continuous linerless media) 0.25 in. to 4.015 in. (other media)
Label length (down-web)**	0.20 in. minimum (die-cut media) 6.95 in. maximum (die-cut material) 0.50 in. minimum (continuous media) 7.125 in. maximum vertical repeat (die-cut media)
Media roll o.d. (max)	4.30 in.
Media roll core i.d.	n/a (media roll integrated into drop-in cartridge)
Media width (cross-web, including liner)	0.71 in. to 4.25 in.
Media thickness	0.0024 in. to 0.031 in. max (label media) 0.070 in. max (B-593 push-button media) 0.043 in. max (heat-shrink sleeves)
Media roll winding	n/a
Brady Print Technology	Yes - Reads datachip on supplies for no-waste printing, requires no calibration, has pre-optimized energy and speed settings and features auto label setup in Brady software
Sensor and energy setting adjustments	No calibration required, no wasted labels, sensor; speed and heat settings are auto-set
Media loading / handling	<b>Labels:</b> In cartridge, drops into place, 15-second changeover <b>Ribbon:</b> In cartridge, snaps into place, 5-second changeover
Media parts offering	1,300+ stock parts and custom (made-to-request) parts. All B30- and B33- series parts are compatible in the BradyPrinter i5300
Media styles	All media is on an integrated cartridge roll with part data on the smart cell. Die-cut media, continuous media, tagstock liner-mounted, tagstock linerless, perforated materials, adhesive labels, heat-shrink sleeves size 0.940 in. and larger (single- and double-sided with 2-pass print), self-laminating cable labels, cable ties and tags, raised panel push-button labels, rapido-style cable tags, PermaShield-style labels, pre-printed GHS labels, SFID outdoor-grade labels, direct thermal labels
Media material types	PE (polyethylene), PET (polyester), PET (metallized), PU (polyurethane), PVC (vinyl), PVF (polyvinyl fluoride), PVDF (polyvinylidene fluoride), PP (polypropylene), PI (polyimide), polyamide, polyether polyurethane (Heatex™), raised panel push-button material, paper, tamper-evident and tamper-resistant materials, 8-10 year outdoor vinyl, 10-hour glow-in-the-dark material, retroreflective labels, printable floor marking tape, nylon and vinyl cloth, wash-down materials, extreme temperature laboratory materials, slides / lab-staining materials, other materials not listed

Ribbon Characteristics:	
Ribbon length (max)	200 ft.
Ribbon roll o.d. (max)	n/a (ribbon roll integrated into drop-in cartridge)
Ribbon roll core i.d.	n/a (ribbon roll integrated into drop-in cartridge)
Ribbon width (cross-web)	4.33 in.
Ink side	n/a (ribbon integrated in cartridge — guaranteed correct orientation to printhead)
Software and Firmware:	
Label Creation Software	Brady Workstation (v4.12 or newer) and Brady Workstation apps (latest updates)
WHQL certified Windows® drivers	Windows 7, 8, 8.1, 10, server 2008, 2008 R2, 2012, 2012 R2, 2017
Printer command language	BPL – scripting commands for sending scripts to the printer
Connectivity:	
PC connection port	1 x USB 2.0 hi-speed device port
Serial port	No
Ethernet	1 x Ethernet 100 BASE-T
USB host ports	3 x USB 2.0 type A host port (1 front, 2 back)
SD card slot	No
Wireless	Wi-Fi 802.11b/g/n (wireless model only)
Bluetooth	Internal Bluetooth module (future functionality)
Electronics:	
Processor	32-bit 800 MHz clock rate
Memory (RAM)	512 MB
Data storage (IFFS)	195 MB
Internal battery	For internal date and time (RTC)
Data storage when power Off	Yes
Physical / Operational Characteristics:	
Dimensions (closed) (HxWxD)	11.0 in. x 11.2 in. x 15.8 in.
Weight (empty)	31 lbs
Power supply	101-240 VAC, 50/60 Hz, 3.5A
Power consumption	20W standby / 80W operating / 200W max
Operating environment	50 - 104°F / 10 - 85% RH non condensing
Storage environment	-4 - 122°F / 15 - 90% RH non condensing
Transport environment	-4 - 122°F / 15 - 90% RH non condensing
Agency approvals	CE, FCC class A, cUL. Contact Brady for up-to-date list of environmental compliance information and agency approvals and / or marks covering over 75 countries (awarded or applied for)
Fonts and Graphics:	
Character sets	ASCII character set
Font types (resident)	Arial, Courier New, MS Gothic, Malgun Gothic, MingLiU, SimSun, Tahoma, Times New Roman, Trebuchet MS, Verdana
Font types (storable to printer)	TrueType fonts storable to printer via jump drive
Font attributes	Bold, italic, underlined
Graphic elements	Arrow, line, rectangle, square, circle, ellipse, diamond, dot, star, triangle, seal, cross
Graphic formats	BMP, GIF, JPEG, PNG
Barcodes:	
Barcode symbologies — 2D	Aztec, DataMatrix, QR Code, PDF-417
Barcode attributes	Sizing: variable in height and ratio Rotation: 0°, 90°, 180°, 270° human-readable and human-readable location density
Barcode symbologies — linear	Code 39, Code 93, Code 128 A, B, C, Codabar, EAN-8, EAN-13, JAN-8, JAN-13, HIBC, Interleaved 2 of 5, Interleaved 2 of 5 with check digit, MSI Plessey, UPC-A
Options / Accessories:	
Replacement printheads	User replaceable (to same dpi)
Replacement print rollers	115 mm width, user replaceable (T10 wrench required)
Auto cutter	Built-in

\* General volume levels for directional model comparison purposes only. Assumes basic text on 1-in. x 2-in. polyester labels. Actual results vary depending on combination of material, burn and speed settings, label content, ambient temperature and length of print run.  
\*\*User should test to the application. Print performance on small parts or parts smaller than a printer's minimum label dimension spec is dependent on multiple factors including print speed, quantity in print run, heat setting, and the size / layout of the printed elements.  
Windows® is a registered trademark of Microsoft Corporation.

# LABEL RIGHT

## in a fraction of the time

Get to printing faster with Brady Workstation



Only **Brady Workstation Label Creation and Management Software** is specifically designed to work with and unleash the full potential of your i5300 Industrial Label Printer.

- ▶ **Simplify Label Creation** – templates, graphics, data importing
- ▶ **Streamline the Process** – auto-formatting, sequencing, lockable fields
- ▶ **Optimize Efficiency** – bundling discounts, task monitoring, storage
- ▶ **Personalize Your Solution** – suites and apps for product, wire and safety ID

▶ **Order with your i5300 printer or learn more at [BradyID.com/Workstation](http://BradyID.com/Workstation).**



We make products that make the world a safer and smarter place. From the depths of the ocean to outer space, from the factory floor to the delivery room — **we're just about everywhere you look.**

► For more information or to learn more about our innovative products, visit [BradyID.com](https://BradyID.com) or call 1-888-272-3946.

USA  
Customer Service: 1-888-272-3946  
[BradyID.com](https://BradyID.com)

Canada  
Customer Service: 1-800-263-6179  
[BradyCanada.ca](https://BradyCanada.ca)

Mexico  
Customer Service: 1-800-262-7777  
Inside Sales: 1-800-262-7777 ext 177  
[BradyID.com.mx](https://BradyID.com.mx)



Y5079978 MS5079978