

Brady

Bradyprinter Models 2461 and 3481

Operator's Manual

(TEMP COVER)
(DO NOT PRINT)

(DO NOT PRINT)

Copyright Information:

CG Triumvirate is a trademark of Agfa Corporation.

CG Times based upon Times New Roman under license from The Monotype Corporation.

Firmware (Software) Agreement

The enclosed Firmware (Software) resident in the Printer is owned by Licensor or its suppliers and is licensed for use only on a single printer in the user's Trade or Business. **The User agrees not to, and not to authorize or permit any other person or party to duplicate, or copy the Firmware or the information contained in the non-volatile or programmable memory.** The firmware (Software) is protected by applicable copyright laws and Licensor retains all rights not expressly granted. In no event will Licensor or its suppliers be liable for any damages or loss, including direct, incidental, economic, special, or consequential damages, arising out of the use or inability to use the Firmware (Software).

Information in this document is subject to change without notice and does not represent a commitment on the part of Brady Worldwide, Inc. No part of this manual may be reproduced or transmitted in any form or by any means, for any purpose other than the purchaser's personal use, without the expressed written permission Brady Worldwide Inc.

All rights reserved. Printed in the United States of America.

© Copyright 2000 by Brady Worldwide, Inc.

Part Number: 88-2241-21

Revision: B

Agency Compliance and Approvals:



UL1950 Information Technology Equipment
C22.2 No. 950-M93



EN60950

For 230 Volt Operation (Europe): Use a cord set, marked "HAR," consisting of a min H05VV-F cord which has a minimum 0.75 square mm diameter conductors, provided with an IEC 320 receptacle and a male plug for the country of installation rated 6A, 250V

Für 230 Volt (Europa): Benützen Sie ein Kabel, das mit "HAR" markiert ist, bestehend mindestens aus einem H05VV-F Kabel, das mindestens 0,75 Quadratmillimeter Drahtdurchmesser hat; sowie eine IEC320 Steckdose und einen für das Land geeigneten Stecker, 6A, 250 Volt.

As an Energy Star Partner, the manufacturer has determined that this product meets the Energy Star guidelines for energy efficiency.



The manufacturer declares under sole responsibility that this product conforms to the following standards or other normative documents:

EMC: EN 55022 (1993) Class B
EN 50024 (1998)
EN 45501 (1992)

Safety: This product complies with the requirements of EN 60950/All:1997



Gost-R

FCC: This device complies with FCC CFR 47 Part 15 Class A.

Note: This equipment has been tested and found to comply with the limits for a Class A digital device, pursuant to Part 15 of the FCC Rules. These limits are designed to provide reasonable protection against harmful interference when the equipment is operated in a commercial environment. This equipment generates, uses, and can radiate radio frequency energy, and if not installed and used in accordance with the instructions in this manual, it may cause harmful interference to radio communications. Operation of this equipment in a residential area is likely to cause harmful interference in which case the user will be required to correct the interference at his own expense.

Important Safety Instructions:

This printer has been carefully designed to give you many years of safe, reliable performance. As with all electrical equipment, there are some basic precautions you should take to avoid hurting yourself or damaging the printer:

- Before using the printer, carefully read all the installation and operating instructions.
- Observe all warning instruction labels on the printer.
- Install the printer on a flat, firm, solid surface.
- To protect your printer from overheating, make sure all openings on the printer are not blocked.
- Do not place the printer on or near a heat source.
- Do not use your printer near water, or spill liquid into it.
- Ensure that your power source matches the rating listed of your printer. If unsure, check with your dealer or local Utility provider.
- Do not place the power cord where it will be stepped on. If the power cord becomes damaged or frayed, replace it immediately.
- Do not insert anything into the ventilation slots and openings on the printer.
- Use a qualified, trained service technician should the printer ever need repair.

Contents

Printer Overview

1.0	Introduction.....	1
1.1	About this Printer.....	2
1.1.1	Standard Features	2
1.1.2	Optional Features	3
1.2	Option Installation	5

Getting Started

2.0	Before using the Printer	7
2.1	Choosing Media and Ribbon	9
2.1.1	Controlling Print Quality.....	9

Printer Setup

3.0	Introduction.....	11
3.1	Connecting the Printer	11
3.1.1	Interfacing	12
3.2	Loading Media.....	14
3.2.1	Roll Media.....	16
3.2.2	Fan-Fold Media.....	17
3.3	Loading the Media Rewinder	18
3.3.1	Winding Labels	18
3.3.2	Winding with the Peel and Present Option	20
3.4	Loading Ribbon	22

Using the Front Panel

4.0	Front Panel Operation.....	25
4.0.1	Ready Mode	25
4.0.2	Menu Mode	26
4.0.3	Quick Test Mode.....	27
4.0.4	Indicators.....	28
4.0.5	LCD (Display).....	28
4.0.6	Factory Default Resetting.....	29

4.1	The Menu System	30
4.1.1	Media Settings.....	31
4.1.2	Print Control.....	32
4.1.3	Printer Options	33
4.1.4	System Settings	34
4.1.5	Communications	38
4.1.6	Diagnostics	40
4.2	Display Messages	42
4.2.1	User Prompts and Condition Messages.....	42
4.3	The Quick Test Mode	44
4.3.1	Print Quality Label.....	44
4.3.2	Configuration Label	45
4.3.3	Quick Ribbon Test Label	46
4.3.4	Dot Test Pattern Label.....	47
4.3.5	Validation Label.....	48
4.3.6	User Defined Label	48

Adjustments and Maintenance

5.0	Introduction.....	49
5.1	Media Sensor Adjustment.....	49
5.2	Positioning Calibration	51
5.3	Media Sensor Calibration	51
5.3.1	Standard Calibration.....	51
5.3.2	Advanced Entry Calibration.....	57
5.4	Printhead Adjustments.....	62
5.4.1	Leveling Cam Adjustment	62
5.4.2	Burn Line Adjustment.....	63
5.5	Printhead Replacement	65
5.6	Cleaning Schedule	66
5.6.1	Cleaning the Printhead	67
5.6.2	Cleaning the Platen Roller.....	68
5.6.3	Interior and Exterior Surfaces	69
5.7	Updating the Application Version.....	69

Troubleshooting

6.0 Introduction..... 73
6.1 General Troubleshooting 73
6.2 Error and Warning Messages..... 77
6.3 Hex Dump Mode 83

Specifications

7.0 Printer Specifications..... 85

Appendix A

ASCII Control Code Chart..... 89

Appendix B

Available Fonts and Bar Codes..... 91

Appendix C

Print Resolutions and Maximum Widths 101
Speed Settings and Defaults 102
Module Assignments..... 100

Appendix D

Warranty Information..... **Error! Bookmark not defined.**

Glossary of Terms..... 107

Index 111



Printer Overview

Section 1

1.0 Introduction

Congratulations on your purchase of the Bradyprinter Model 2461 or 3481. This printer family, hereafter referred to as 'the printer', blends the rugged durability of solid-frame construction with other innovative design features to redefine the standard in industrial thermal printers.

The printer incorporates highly specialized electronics, including a powerful 32-bit processor and up to 16 megabytes* of on-board memory. Control and program changes can be made smoothly, with most functions accessible through either the front panel or labeling software. The user-friendly printing concept is taken a step further with the quick-load media design, easily added application upgrades, and modularly installed options.

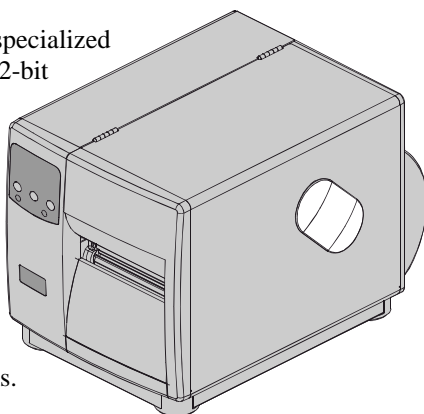

This manual provides all the information necessary to operate the printer on a daily basis. To print labels or tags simply refer to the instructions included with the software you have chosen to create the labels. If you wish to write a custom program, a copy of the *Programmer's Manual* is included on the Accessories CD.

*The amount of resident memory is model dependent.

1.1 About this Printer

To meet all of your printing needs this unit is easily configurable. This section lists the available standard and optional hardware features.

1.1.1 Standard Features

This printer offers the following standard features:

Standard Features Table		
Feature	Printer Model	
	2461	3481
Printhead Density (Dots Per Inch)	203	300
Direct Thermal Printing	X	X
On-Demand and Batch Printing	X	X
Media Hanger for 1.5" and 3.0" I.D. rolls	X	-
Rotating Media Hub for 1.5" or 3.0" I.D. rolls	-	X
Simple media loading	X	X
Media Tear Bar	X	X
Fan-fold media handling	X	X
Flash programmable downloadable memory	1MB	2MB
SDRAM	8MB	16MB
RS-232 serial interface	X	X
IEEE 1284 Compliant parallel interface	X	X
2 X 20 Character, Liquid Crystal Display (LCD)	X	X
EFIGS (English, French, Italian, German, and Spanish) display languages	X	X
AGFA Scalable font engine with CG Triumvirate Scaleable and CG Triumvirate Bold Condensed Font	X	X
Printhead Resistance Verification	X	X

1.1.2 Optional Features (available except as noted)

This printer offers the following optional features:

Light-Duty Cutter

A rotary-type cutter for cutting material with a maximum thickness of .005” (.127mm).

Standard Cutter

A rotary-type cutter for cutting labels and tags with a maximum thickness of .010” (.254mm).

Cutter Tray

For use with the optional cutter, this tray collects the cut labels and tags.

External Keyboard Support

Allows the connection of the Passport™ external keyboard.

Font Expansion Card (cannot be used with the I/O Expansion option)

A slide-in circuit card assembly with 8MB Flash memory expansion, adding another module (configured in two 4MB partitions) for ILPC and/or additional fonts and graphics. ILPC-International Language Printing Capability, consisting of one of the following:

- CG-Times™ (Western European) Scalable
- Kanji Gothic B Scalable font
- Simplified Chinese GB Scalable font

Internal Media Rewinder

Available to rewind labels or backing material up to a six inch outer diameter capacity and essential for use with the Peel and Present option.

I/O Expansion Card* (specify features at time of order)

A slide-in circuit card assembly with the following standard features:

- General purpose (GPIO) interface for external printer and device control.
- Time and Date (Real Time Clock) function.

And the following optional feature:

- 8MB Flash memory expansion, adding another module (configured in two 4MB partitions) for ILPC and/or additional fonts and graphics.

LAN Interface

A slide-in circuit card assembly that provides network connectivity, allowing multiple users on various platforms to share the same printer.

Peel and Present Mechanism *(requires the Internal Rewind option)*

A device used to automatically separate printed labels from the backing material on-demand.

Present Sensor

A device to control the printer's output, where subsequent printing occurs only after the removal of a previously print label.

RS-422 Serial Interface*

Single-drop interface hardware to support greater distances from the host at communication rates of up to 38,400 baud.

Thermal Transfer

This method uses ribbon to produce exceptional image clarity, as compared to most direct thermal media types. This option can be ordered for use with either 'coating in' or 'coating out' type ribbons, and must be specified when ordering.

Twinax/Coax Interface

A slide-in circuit card assembly that provides connectivity to AS/400 and System/3X Twinax host system or 3270-type host system. Cable included.

*These items are not available for the 2461 model printer.

1.2 Option Installation

The following table lists the available options and the recommended qualification level of the installer. For detailed information concerning a specific option, contact your sales support representative or Technical Support.

Option	Qualified Installer
Cutter Tray	Operator
Cutters: Light and Standard Duty	Operator
Passport External Keyboard	Operator
Font Expansion Card	Certified Technician
Internal Rewind	Operator
I/O Expansion Card	Certified Technician
LAN Interface	Certified Technician
Peel and Present Mechanism	Operator
Present Sensor	Operator
RS-422 Serial Interface	Certified Technician
Thermal Transfer Assembly	Operator
Twinax/Coax Interface	Certified Technician



Getting Started

Section 2

2.0 Before using the Printer

Unpacking

Inspect the shipping container(s) for damage; if evident, immediately notify the shipping company to report the nature and extent of the damage.

The printer has been carefully packaged to avoid damage during transit. In order to operate the printer, you will need to remove the packaging materials (i.e., tape and foam) placed there for shipment. Complete the following steps prior to connecting power or attempting to load media.

- ❶ With the arrow on the box pointing up, open the box.
- ❷ Remove Accessories Box.
- ❸ Tilt the printer on its side and slide the printer out of its box.
- ❹ Place the printer in an upright position and remove the packing foam, plastic bag, and tape.

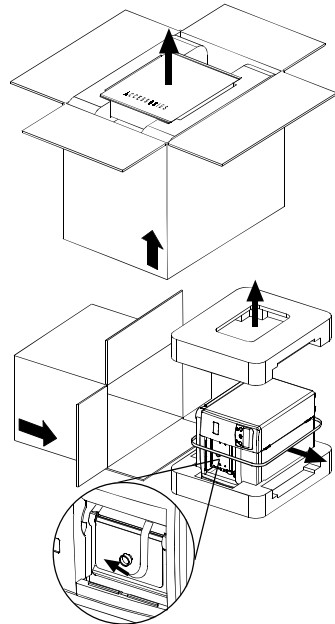

Note: It is a good idea to save the carton and packaging materials in the event that future shipment is ever required.

Inspection

After removing the printer from the packaging material, check the contents of the package. In addition to this manual, the following items should be included:

- Printer
- Power Cord
- Accessories CD
- Any special or additionally purchased items.

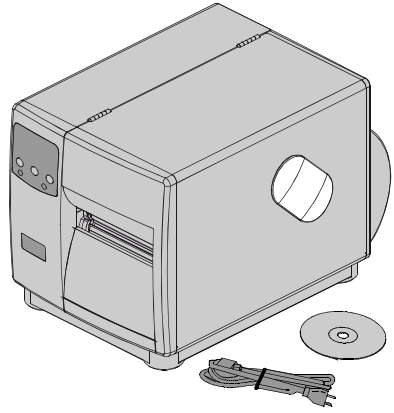

Additional Requirements

The following items are necessary for generating and printing labels. Contact your customer support representative for advice on which media and software may best suit your needs.

- Serial or parallel interface cable
- Applicable media
- Applicable software

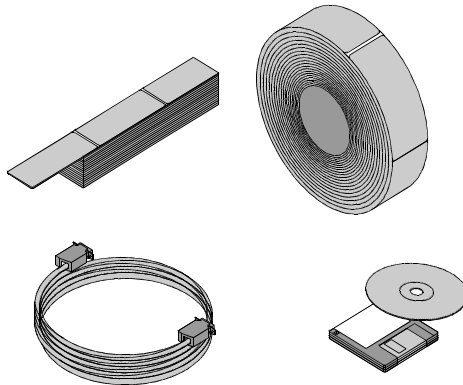

2.1 Choosing Media and Ribbon

The following is a limited overview of media characteristics. For complete information and advice regarding your specific application needs, always consult a qualified media specialist or a Media Representative.

Media Selection – Direct Thermal

Consider three important factors when selecting direct thermal stock:

- The abrasive qualities of the material that covers the thermal reactive layer of the paper.
- The ability of that layer to control the chemical reaction that occurs when the image is “burned”.
- The amount of heat required to create an image on the paper.

Media Selection – Thermal Transfer

Consider three important factors when selecting thermal transfer media combinations:

- The label top coating and ribbon combinations affect image quality.
- Ribbon backcoating is highly recommended. It provides protection for the printhead and may also provide an anti-static coating.
- Use a ribbon of equal or slightly greater width of the overall width of the label (including the backing material).

2.1.1 Controlling Print Quality

The printer can provide maximum application flexibility with a comprehensive set of print controls. The amount of heat applied per dot row and the rate at which the paper moves under the printhead have the most effect on images that are printed. The printer allows you to control these factors but also limits them so you cannot ask the printer to print an image that could be damaging. For example, low cost direct thermal stocks have very high reaction temperatures. It takes high heat to make a clear image on this type of paper. There are four methods of compensation:

- The first is the ‘Media Type’ menu setting, which should be set to match the media type (i.e., when printing with ribbon use the thermal transfer setting).

- The second method, if only subtle contrast changes are desired, would be to change the ‘Custom Adjustments / Darkness’ menu setting.
- The next method would be to change the ‘Print Control / Heat’ menu setting (also selectable as ‘Heat’ in most software programs). Increasing this value causes more energy to be transferred to the media, resulting in a darker image.
- The final method would modify the ‘Print Control / Print Speed’ menu setting (also selectable as ‘Print Speed’ in most software programs). Reducing the print speed will allow the media to remain under the printhead longer, and increasing the time for energy to be transferred.

You will find that printing fine images on less expensive direct thermal and thermal transfer media at higher speeds can be tricky. At one heat setting, the image will fade and at the next higher heat setting, the image will bleed. This is because the reaction temperature of the media is so high that at higher rates of speed, it cannot react fast enough. To print fine images at higher speed, media with lower reaction or release temperatures are required. On the slower end of the print rate settings, crisper images are possible because the media is not being stretched beyond its limits.

The following table is intended for reference only (for specific application information, consult with your media specialist or a Media Representative).

Direct Thermal Media Type	Print Speed*	Print Energy
Fasson 300 HD™ Direct Thermal Facesheet	10-12**	Medium
Fasson 300 MD™ Direct Thermal Facesheet		

Thermal Transfer Media Type	Ribbon Type	Print Speed*	Print Energy	Image Durability
Great Label TTL™	GPR Plus™ MaxWax™ IIMAK Versamark™	10-12**	Medium	Medium
Coated Paper, Uncoated Paper, Tag Stock, Some Films, Some Synthetics	Wax	2 - 10	Low	Low
Coated Paper, Glossy Paper, Tag Stock, Some Synthetics, Films	Wax/Resin	2 - 8	Medium	High
Synthetics, Films	Resin	4 - 6	High	High

*Values given in inches per second (IPS)

**For optimum print quality at speeds above 10 IPS these are highly recommended.



Setting Up the Printer *Section 3*

3.0 Introduction

This chapter explains how to connect the printer and load media and ribbon.

3.1 Connecting the Printer

Note: When connecting the AC power cord or data cables to the printer, ensure the power switch is in the 'Off' position.

Connect the AC power cord to the receptacle located on the back of the printer, then plug the cord into a properly grounded outlet.

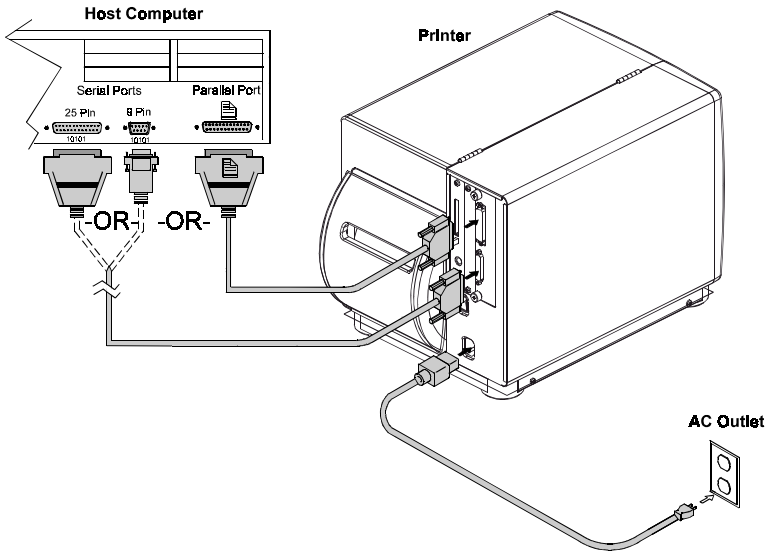

 For ease of connectivity, the printer can be connected to the Host Computer through the parallel or serial interface, as described in Section 3.1.1.

3.1.1 Interfacing

The interface selection process in the printer occurs by data detection. Once detected, the receiving port is set 'active'. It will remain active, as long as data flow continues; however, if data inactivity occurs and the Host Timeout Value (see Section 4.1.5) is exceeded the selection process will automatically be repeated. When timeout occurs before a complete label format has been received, all data will be lost and the format must be sent again. To change an active port immediately, cycle power 'On' and 'Off'.

Parallel Port:

The parallel port interface has two menu selectable modes of operation: uni-directional or bi-directional. Uni-directional mode is forward channel communication and requires a Centronics[®] cable with a 36 pin male connector. Bi-directional mode is IEEE 1284 Compliant, using forward and reverse channel communications. In this mode, data can be sent to the host provided it is also IEEE 1284 Compliant and has supporting software. This mode requires an IEEE 1284 cable with a Centronics[®] 36 pin male connector.

Serial Port:

The serial port interface supports RS-232C and, if equipped, RS-422 communications. The list of printer settings below are menu selectable and be set must match the host computer settings; see Section 4.1.5.

- Baud Rate (communication speed)
- Word Length
- Word Parity
- Number of Stop Bits
- Handshaking Protocol

In addition to these settings, the serial interface cable must have specific pin configuration (pin-out) for proper data exchange. The different serial cables, their respective pin configurations, suggested applications and part numbers are shown on the next page (contact your reseller for ordering information).

Serial Interface Cable Listing (all models except as noted)

Null Modem (MXM)

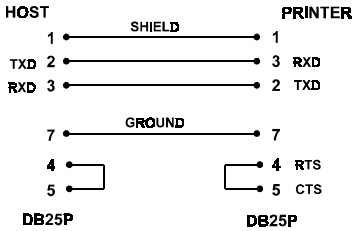

Part Number 556000

Cable used for typical connection to other DCE equipment with Xon/Xoff flow control.

“PC” (DB9P) to Printer

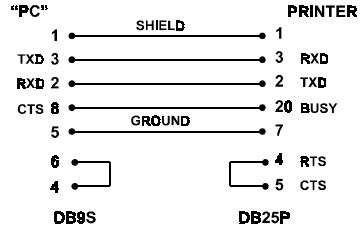

Part Number 556001

Cable used for connection to a PC compatible with DB9P communication ports. Flow control can be either Xon/Xoff or CTS/DTR.

“PC” (DB25P) to Printer

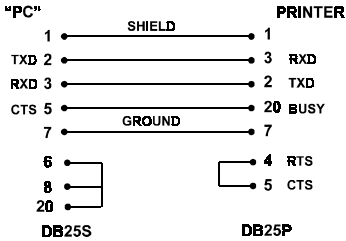

Part Number 556002

Cable used for connection to a PC compatible with DB25 communication ports. Flow control can be either Xon/Xoff or CTS/DTR.

RS-422 Connection*

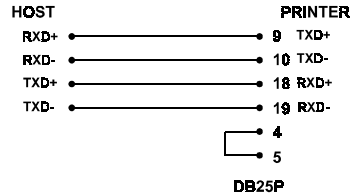

Part Number N/A

*This is an optional interface, but is unavailable on the 2461. The diagram above is provided only as a guide.

3.2 Loading Media

The following procedures explain the preliminary media loading steps.

- ❶ Raise the Access Cover.
- ❷ Rotate the Printhead Latch forward to raise the printhead.
- ❸ Slide the Media Guide out away from the frame and then lower it to the down position.
- ❹ Referencing the drawings on the next page, determine the type of media mounting device in the printer: Media Hanger or Rotating Media Hub.
- ❺ If the printer is equipped with a Media Hanger, slide the Media Retainer out, away from the frame and then lower it to the down position.

-Or-

If the printer is equipped with the optional Rotating Media Hub, it can accept two different core sizes: 3.0" (76mm) or 1.5" (38mm). When using 1.5" core media, first remove the 3.0" hub by grasping it and then pulling firmly out and off. Store the removed hub in a safe place for future use.

Note: This printer is left justified. Always place the media against the backstop when loading.

 Depending upon the type of media and printer options, several loading methods are possible. All are detailed in the following sections.

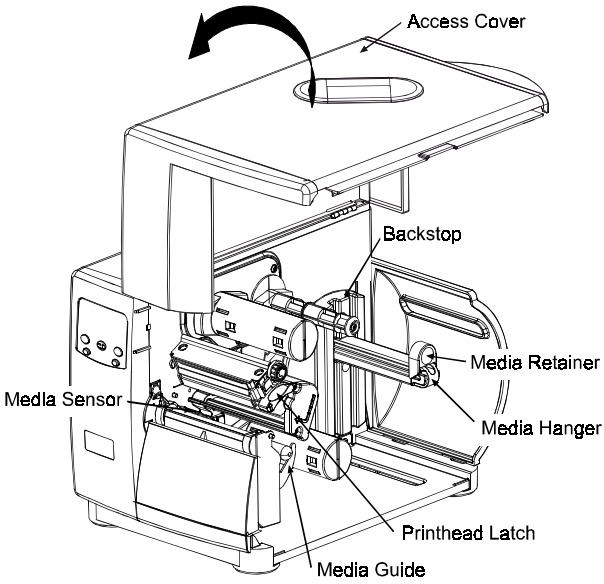

Media Hanger equipped printer

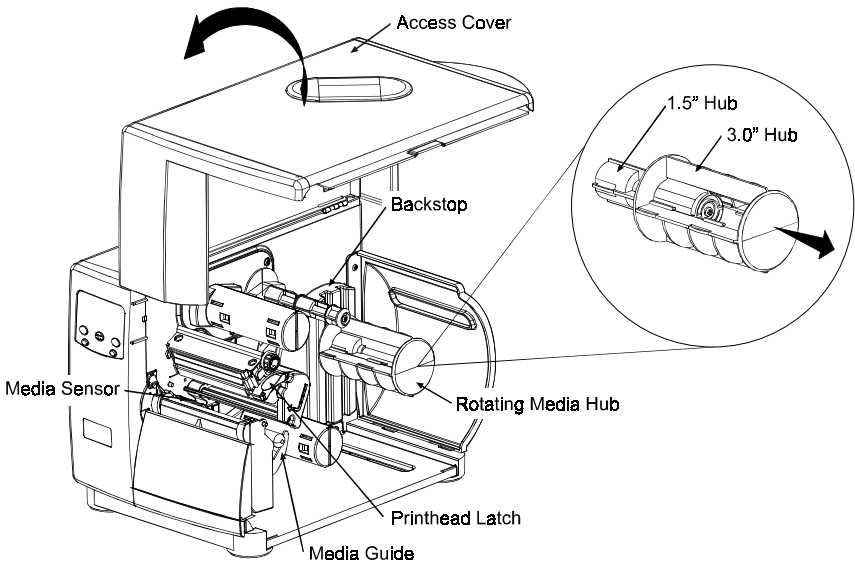

Rotating Media Hub equipped printer

3.2.1 Roll Media

- 1 **Media Hanger equipped:** place Roll Media onto the hanger as shown, sliding it over against the Backstop; then raise the Media Retainer and slide it over to rest firmly against the roll.

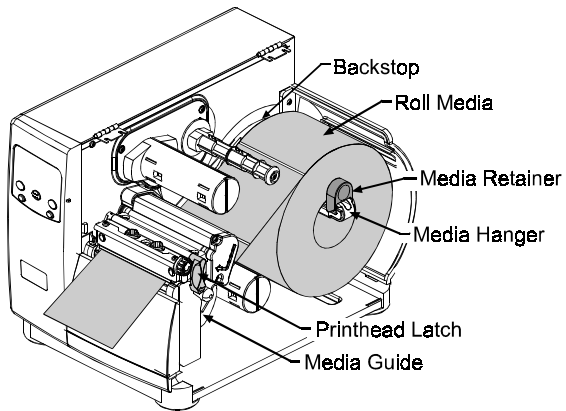

Rotating Media Hub equipped: place Roll Media onto the hub, sliding it over against the Backstop.

- 2 Route the media through the printer as shown below: under the Media Idler, through the Media Sensor and out the front of the printer.
- 3 Raise and slide the Media Guide over to rest lightly against the media's edge.
- 4 Slide the Media Sensor into position; see Section 5.1 for details.
- 5 Lower the printhead and rotate the Printhead Latch back to the locked position. Close the Access Cover.

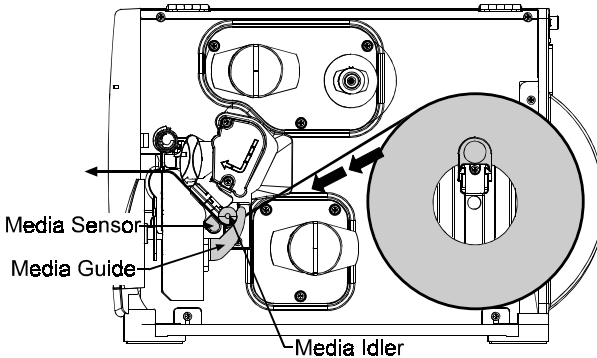

- ☞ If you are printing with thermal transfer media, see Section 3.4 for ribbon loading instructions.
- ☞ If you have a thermal transfer printer but will be printing on direct thermal labels, see Section 4.1.1 for instructions to select direct thermal media in the Media Settings menu.

3.2.2 Fan-Fold Media

- 1 Bring the media in through the Bottom or the Rear Media Slot.
- 2 Route the media as shown below: over the Media Hanger (or Rotating Media Hub) when entering through the Rear Media Slot; or if entering through the Bottom Media Slot, route the media over the Media Rewind Hub.
- 3 Continue routing the media under the Media Idler, through the Media Sensor and out the front of the printer.
- 4 Raise and slide the Media Guide (and Media Retainer if Media Hanger equipped and using the Rear Media Slot) over to rest lightly against the media's edge.
- 5 Slide the Media Sensor into position; see Section 5.1 for details.
- 6 Lower the printhead and rotate the Printhead Latch back to the locked position. Close the Access Cover.

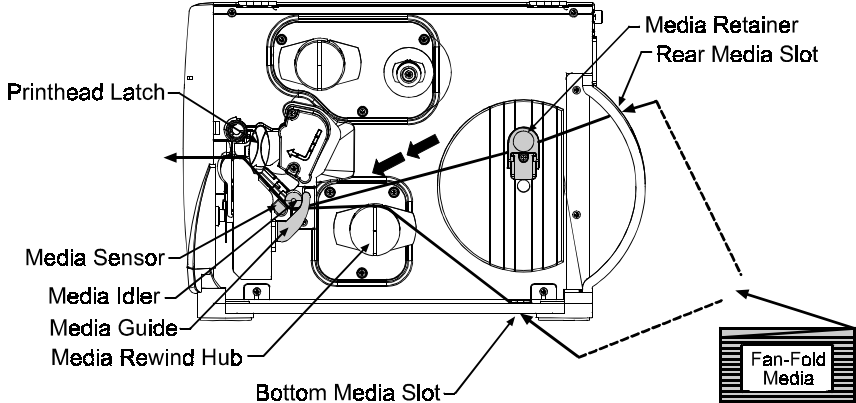

- ☞ If you are printing with thermal transfer media, see Section 3.4 for ribbon loading instructions.
- ☞ If you have a thermal transfer printer but will be printing on direct thermal labels, see Section 4.1.1 for instructions to select direct thermal media in the Media Settings menu.

3.3 Loading the Media Rewinder

With the Media Rewinder option, the printer can wind labels and backing material. When equipped with the Peel and Present option, labels can be separated automatically. The following subsections illustrate both set-ups:

3.3.1 Winding Labels

Note: When winding labels, the outer diameter of the wound stock cannot exceed 6".

- 1 Remove the Front Fascia.

- 2 Remove the Tear Plate by first removing the Thumbscrew.

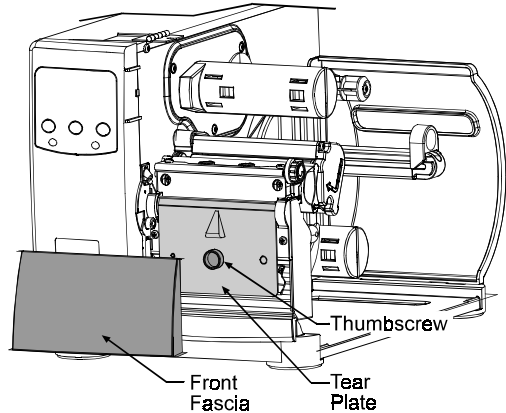

- 3 Position the Rewind Plate on the printer and install and tighten the Thumbscrew.

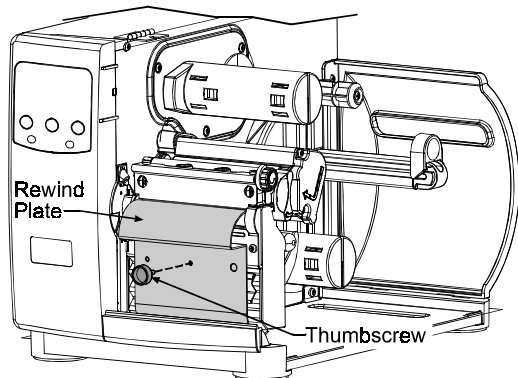

- 4 Remove the Media Retainer from the Media Rewind Hub.
- 5 With media loaded as described in Section 3.2, press the FEED key to advance approximately 20 inches of media.

(Continued next page)

- ⑥ Route the media back to the Media Rewind Hub as shown below.
- ⑦ Insert the edge of the labels into the Slot on the Rewind Hub and then insert the Media Retainer into the Slot.
- ⑧ Slide the Media Retainer over the media and onto a Slot on the Media Rewind Hub and rotate the hub to remove any slack in the Media.

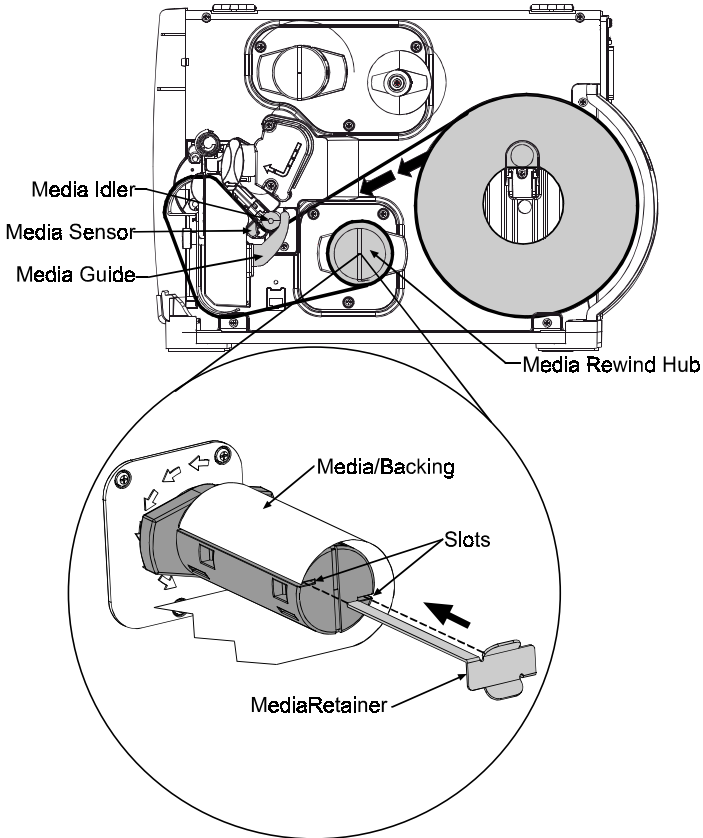

After loading, close the Access Cover and then press the FEED key to secure the media.

Removal:

Grasp the printed labels on the Media Rewind Hub, and while gently pulling on the hub, compress the hub and pull off the labels.

3.3.2 Winding with the Peel and Present Option

The printer can separate the labels from the backing material “on-demand” when equipped with the Peel and Present Mechanism. Complete the following steps for automatic separation:

❶ With media loaded as described in Section 3.2, and the Peel and Present Mechanism installed on the printer, loosen the two Thumbscrews on the front of the Roller Bracket, allowing the bracket to swing down.

❷ Press the FEED key and advance approximately 20 inches of media from the front of the printer.

❸ Remove the labels from the backing material.

❹ Route the backing through the Roller Bracket, as shown below; next, raise the Roller Bracket and tighten the two Thumbscrews.

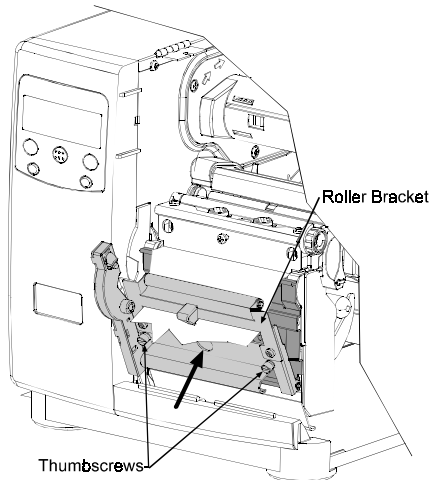
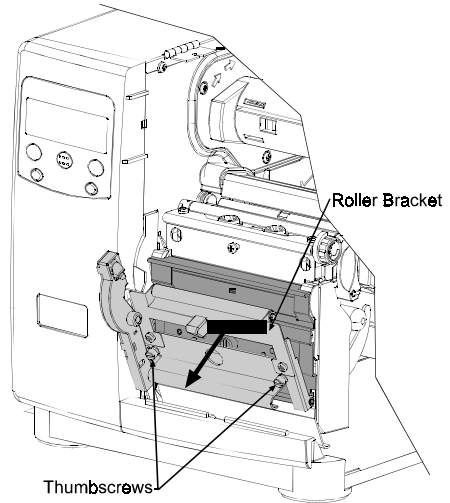

(Continued next page)

- ⑤ Route the Label Backing back to and around the Media Rewind Hub, as shown.
- ⑥ Insert the edge of the Label Backing into the Slot on the Rewind Hub and then insert the Media Retainer, into the Slot on the Rewind Hub. Rotate the Rewind Hub to remove any slack in the Label Backing.

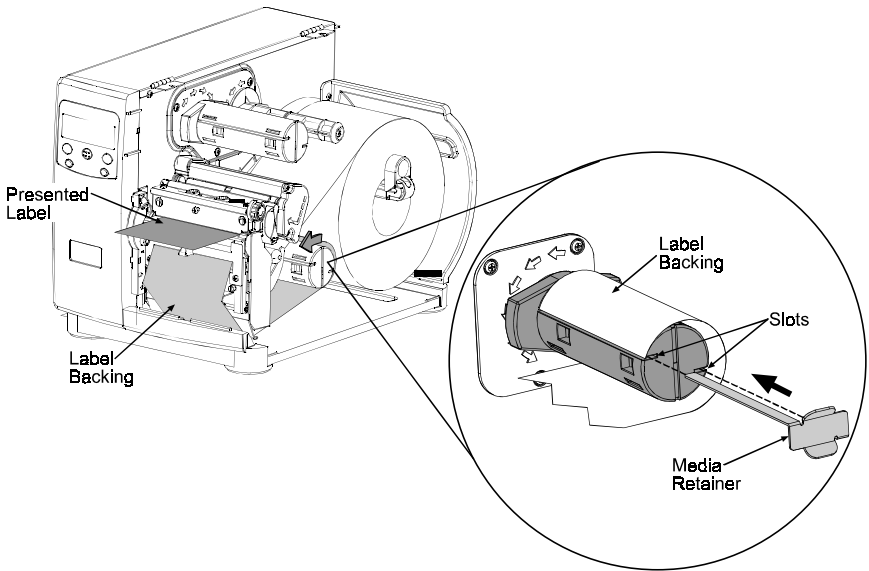

After loading, close the Access Cover and then push the FEED key to secure the backing material.

☑Note: To print on-demand, load the media as described above, and enable the Present Sensor as detailed in Section 4.1.3.

Removal:

Grasp the used backing on the Media Rewind Hub, and while gently pulling out on the hub, compress the hub and pull off the backing.

3.4 Loading Ribbon

Note: Always use ribbon slightly wider than the media backing material; this helps protect against printhead wear.

To produce an image on the label, thermal transfer media requires ribbon. Ribbon types are available with the 'ink' layer on the outside (coating side out) or with the 'ink' layer on the inside (coating side in). These types cannot be interchanged in the printer. Arrows on the Ribbon Supply Hub are used to indicate the correct direction of ribbon travel (see the next page for examples). To load a ribbon:

- 1 Raise the Access Cover.
- 2 Rotate the Printhead Latch forward and raise the printhead.
- 3 Depending upon the directional arrows of the Ribbon Supply Hub (see the next page for examples), mount the ribbon so that it is dispensed in the appropriate direction for the ribbon type.
- 4 Slide the ribbon on completely to rest against the flange.
- 5 Route the ribbon under the Ribbon Roller then out the front of the printer.
- 6 Continue routing the ribbon up to and around the Ribbon Take-Up Hub, as shown. Wind the ribbon around several times in a clockwise direction to secure it in place.
- 7 Lower the printhead and rotate the Printhead Latch back to the locked position. Close the Access Cover.
- 8 With the printer 'On' press and hold the FEED button for three seconds to position the media for printing; see Section 5.2 for details.

Removal:

Pull the empty core from the Ribbon Supply Hub and discard it. Next, grasp the used ribbon on the Ribbon Take-Up Hub, while gently pulling out on the hub, compress the hub to pull off the used ribbon.

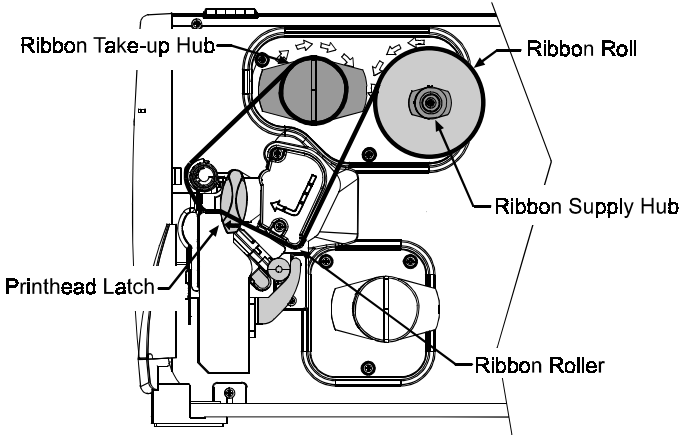

'Coated Side In' Ribbon routing path

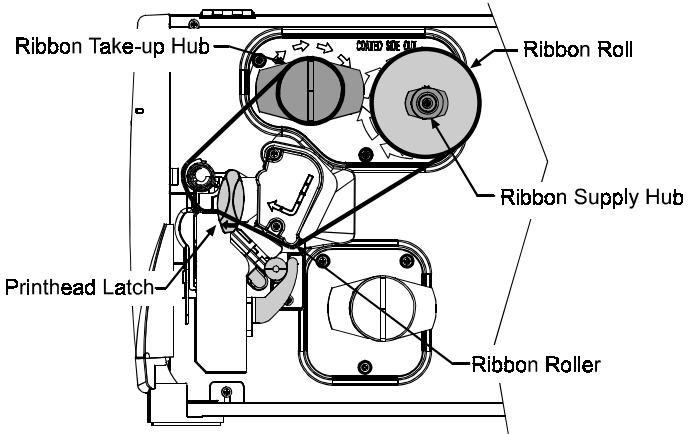

'Coated Side Out' Ribbon routing path



Using the Front Panel

Section 4

4.0 Front Panel Operation

The front panel is equipped with five keys, 3 indicators and a Liquid Crystal Display (LCD). The key functions differ depending upon the selected mode. The selectable modes are Ready, Menu and Quick Test.

4.0.1 Ready Mode: Normal Operation (Ready Light 'On')

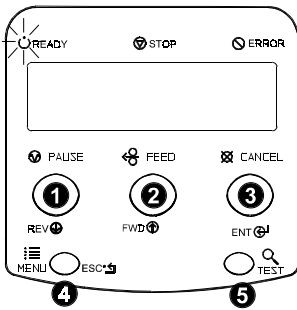

1 PAUSE

Pressing the PAUSE key temporarily suspends printing. Pressing again returns the printer to normal operation.

2 FEED

The FEED key advances one label, and clears any faults that have been corrected.

Pressing and holding this key 4 seconds will calibrate the label position.

3 CANCEL

The CANCEL key cancels a job and 'Pauses' the printer.

Pressing and holding this key 4 seconds will reset the printer and clear temporary host settings.



4 MENU

The MENU key toggles between the Ready and Menu Modes.

In the Ready mode, pressing and holding 4 seconds will change the display contrast.

5 TEST

Pressing the TEST key enters the Quick Test Menu.

4.0.2 Menu Mode: Configuration (Ready Light 'Flashing')

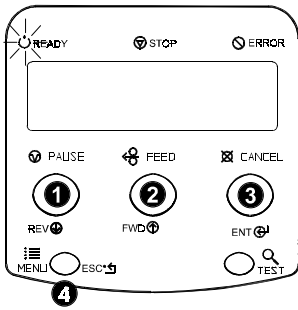

❶ REV ⬇️

The DOWN ARROW key moves to the previous (reverse) menu item; also, decrements numerical values within certain menu selections.

❷ FWD ⬆️

The UP ARROW key moves to the next (forward) menu item; also, increments numerical values within certain menu selections.

❸ ENT ↵

The ENTER key selects function or value displayed in the LCD (selection is indicated with an '*'); also, moves between selections in multiple parameter fields.

❹ ESC ↶

The ESCAPE key moves to the previous menu level, and finally back to the READY mode.

4.0.3 Quick Test Mode: Print Test Labels

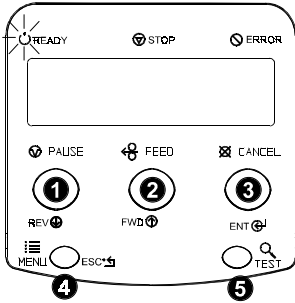

1 REV

Pressing the DOWN ARROW key scrolls to the previous test function.

2 FWD

Pressing the UP ARROW key scrolls to the next test function.

3 ENT

Pressing the ENTER key will change the selected test label quantity of 2, 100, 1000, or 9999 (the 'Configuration Label' is always one). Holding down the key scrolls to the desired quantity.

4 ESC

Pressing the ESCAPE key will exit the Quick Test Mode without printing.

5 TEST

Pressing the TEST key will print the selected test label at the selected quantity.

Notes: When performing a Quick Test, press **ESC ** or ** TEST** to abort printing.

The test functions are disabled while processing communications data.

4.0.4 Indicators

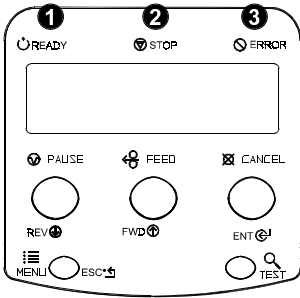

1 READY

'On' indicates READY Mode.

'Slow Flashing' indicates MENU Mode.

'Fast Flashing' indicates received data is being processed.

2 STOP

'On' indicates a 'Paused' state.

3 ERROR

'Slow Flashing' indicates a *Warning*.

'Fast Flashing' indicates an *Error*.

Section 6.2 lists the corresponding display messages.

4.0.5 LCD (Display)

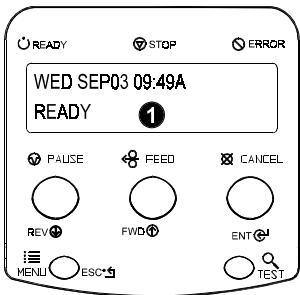

1 Liquid Crystal Display

The display provides several types of information:

- After the power on sequence is complete, the READY message.
- The time and date, if the printer has received it from one of the following: the host, the front panel setting, or the Time and Date option.
- A label counter during a batch print job.
- Any prompt, condition, downloading, error, or warning messages.

4.0.6 Factory Default Resetting

Depending upon the method used, there are two factory default reset levels possible:

☑Note: See Section 4.1 for the factory default settings.

Level 1: To return the printer to factory default settings only: press and hold the PAUSE and CANCEL keys; continue to depress the keys until the 'SYSTEM RESET' message flashes.

Level 2: Highest level; will return the printer to factory default settings, and will reset all calibration and adjustment parameters, to execute: press and hold the PAUSE, FEED, and CANCEL keys; continue to depress the keys until the 'SYSTEM RESET' message flashes.

☑Note: After performing a Level 2 Reset, the printer requires that both Ribbon and Media Calibrations be performed; see Sections 5.2 and 5.3.

4.1 The Menu System

The printer operation can be controlled through the menu system user interface, allowing the operator access to these six menu branches:

- Media Settings
- Print Control
- Printer Options
- System Settings
- Communications
- Diagnostics

Changes made in the menu system can be saved, so that the configuration will not be lost if power is removed. And as a security feature, and to prevent accidental changes, the user interface has a password protection feature.

The same functional commands from the host computer may, in some cases, override the printer's menu settings. If the host sends a reset command, the current configuration (including host changes) will be saved. The current selection is indicated with a '*' on the LCD, while selections designated with '\$' require a printer reset before becoming effective. A reset will be automatically invoked upon exiting the menu system and answering 'Yes' to the 'Save Changes' prompt.

❑ Notes: The factory default settings are denoted with the '◇' symbol in the following subsections.

Some menu settings can only be changed through the Front Panel. These are denoted with the '◆' symbol in the following subsections. All other menu settings can be overridden by host software commands. Consult the *Programmer's Manual* for specific command information.

While in the Menu System, the printer will stop processing new DPL (or bitmapped) data.

While communicating, the Quick Test function is disabled.

4.1.1 Media Settings



From Ready Mode, press the MENU key to enter the Menu Mode.

Note: Entering the menu will clear memory of any settings sent from the host – unless the host has reset the printer.

MEDIA TYPE	<i>Selects a print method.</i>
DIRECT THERMAL	<i>For use with heat sensitive media.</i>
◇ THERMAL TRANSFER	<i>For use with media requiring a ribbon to create an image.</i>

SENSOR TYPE	<i>Selects the top-of-form (TOF) sensing method for the media.</i>
◇ GAP	<i>The printer recognizes the TOF by sensing gaps in the media.</i>
CONTINUOUS	<i>No TOF sensing. The user must use the LABEL LENGTH setting to determine TOF.</i>
REFLECTIVE	<i>The printer recognizes the TOF by sensing registration (black) marks on the underside of media.</i>

LABEL LENGTH ◇ 04.00in (0-99.99)	<i>For use with continuous media. Label length is used to determine the TOF when ‘Sensor Type-Continuous’ is selected.</i>
--	--

MAXIMUM LABEL LENGTH ◇ 16.00in (0-99.99)	<i>Sets the maximum length between TOF marks (gap or black stripe). If this limit is exceeded, a top of form fault is declared.</i>
--	---

SENSOR CALIBRATION ◆	<i>Adjusts the printer to sense your media.</i>
PERFORM CALIBRATION	<i>The User enters the empty, gap or mark and paper values to set the media sensor.</i>
ADVANCED ENTRY	<i>User directly inputs the best gain values to adjust the media sensor.</i>
SENSOR GAIN	<i>Observe A/D reading and set SENSOR GAIN. Adjusts the sensitivity of the sensor for custom label stock. Higher gain means more sensitivity; however, when set too high the printer loses the ability to distinguish gap or mark from paper.</i>
SENSOR LEVELS	<i>Sets threshold values for the media sensor parameters. Entry for paper, gap/mark, and empty thresholds.</i>

4.1.2 Print Control

HEAT ◇10 (0-30)	<i>Controls the printhead 'burn-time'. See Section 2.1.1 for more on print quality control.</i>
PRINT SPEED 2-12 in/sec	<i>Controls the rate of label movement during the printing process; see Appendix C.</i>
FEED SPEED 2-12 in/sec	<i>Controls the rate of label movement between printing areas; see Appendix C.</i>
REVERSE SPEED 2-6 in/sec	<i>Controls the rate of label movement during backup positioning for start of print, cutting or present distance; see Appendix C.</i>
ROW OFFSET ◇00.00in (0-99.99)	<i>Shifts the vertical start of print position. This is the user setting for row adjustment.</i>
COLUMN OFFSET ◇00.00 in (0-99.99)	<i>Shifts the left-justified horizontal start of print position to the right.</i>
LABEL WIDTH 1.00-4.16 inches	<i>Sets the maximum limit for the printable surface width. Images or data beyond this limit will not print; see Appendix C.</i>
PRESENT DISTANCE ◇0.00 in (0-4.00)	<i>Specifies an additional amount to advance the label after printing. When the next label format is received, the printer backfeeds to the start position. Only the last label of the batch will be presented if the present sensor is not enabled.</i>
CUSTOM ADJUSTMENTS ◆	<i>These factory adjustments independently change listed parameters, negating slight mechanical differences sometimes evident when multiple printers share the label formats.</i>
DARKNESS XX (1-64)	<i>Controls the printhead strobe time to fine-tune the HEAT setting.</i>
ROW ADJUST XXX DOTS (1-128)	<i>Shifts the vertical start of print position upward in dots to fine-tune the ROW OFFSET setting; see Appendix C.</i>
☑Note: A Positioning Calibration must be performed before this parameter takes effect; see Section 5.2.	
COLUMN ADJUST XXX DOTS (1-128)	<i>Shifts both the horizontal start of print position and the LABEL WIDTH termination point to the right in dots to fine-tune the COLUMN OFFSET setting; see Appendix C.</i>
PRESENT ADJUST XXX DOTS (1-128)	<i>Adjusts the label stopping position in dots to fine-tune the PRESENT DISTANCE setting; see Appendix C.</i>

4.1.3 Printer Options

MODULES	<i>The physical presence of the respective memory module must be detected to show the module function selections for that module in the menu system.</i>
PRINT DIRECTORY	<i>Prints a label directory of all available modules, the available space on these modules, the files present, and the type of module and files.</i>
PRINT FILE	<i>The user may select from a list of available files for printing.</i>
FORMAT MODULE	<i>The user may select from a list of available modules for formatting – all data will be erased.</i>
DELETE FILE	<i>The user may select from a list of available files for deleting.</i>
PACK MODULE	<i>Packing the module removes files marked as deleted and defragments existing files structures to recover space.</i>
PRESENT SENSOR	<i>Used for on-demand label dispensing, where a printed label blocking the sensor will inhibit the further printing until removed. The physical presence of the Present Sensor must be detected to show the ENABLE/DISABLE selections in the menu system.</i>
ENABLE	<i>Enables the sensor for on-demand printing.</i>
◇DISABLE	<i>Disables the sensor.</i>
NOT INSTALLED	<i>No sensor can be detected.</i>
CUTTER	<i>Physical presence of a cutter must be detected to show the ENABLE/DISABLE selections in the menu system.</i>
ENABLE	<i>Enables the cutter for label cutting.</i>
◇DISABLE	<i>Disables the cutter.</i>
NOT INSTALLED	<i>No cutter can be detected.</i>

4.1.4 System Settings

MEMORY SETTINGS ♦	<i>Allows user to allocate use of printer memory.</i>
INTERNAL MODULE ♦1024 KB (100-16384)	<i>Sets the number of 1K blocks allocated for the internal RAM 'D' module. Available memory dependent upon model; see Appendix C.</i>
SCALEABLE FONT CACHE ♦0312 KB (100-16384)	<i>Sets the number of 1K blocks allocated for the scaleable font engine. Available memory dependent upon model; see Appendix C.</i>
SYMBOL SET SELECT	<i>Selects the code page used by the printer unless otherwise specified in DPL.</i>
♦PC_850 MULTILINGUAL	<i>29 selections are standard, see the Programmer's Manual for details.</i>
DATE AND TIME	<i>Allows the user to set Date/Time.</i>
MEDIA COUNTERS	<i>Internal record of inches printed and time in use.</i>
ABSOLUTE COUNTER	<i>Shows the number of inches printed and number of hours of the printer has been powered 'On' since being set at the factory. Not resettable by the user.</i>
RESETTABLE COUNTER	<i>The number of operational hours and inches printed from the date last reset. User may reset.</i>
RESET COUNTER	<i>Resets the resettable counters to zero.</i>
PRINT CONFIGURATION	<p><i>Prints the effective configuration of the system. In addition, if settings were changed that require a reset to become effective, this will be indicated with the '\$' symbol.</i></p> <p><i>A '•' symbol next to the printed item indicates that it was changed via the host but not saved in non-volatile memory</i></p>

(Continued next page)

System Settings (continued)

<p>CONFIGURATION LEVEL</p>	<p><i>Note: Reserved for future use – current printer configuration does not allow these values to be modified. This information may change at a later date.</i></p> <p><i>To upgrade the application (resident software) of the printer, the hardware and software compatibility levels must match for the update to be accepted. This information is displayed here and can also be found printed on the configuration label.</i></p>
<p>PRINTER KEY</p>	<p><i>Each printer has a unique KEY number in the following form:</i></p> <p style="text-align: center;"><i>vvvv-wwxx-yyyyyy-zzz</i></p> <p><i>where:</i></p> <p style="padding-left: 40px;"><i>vvvv – represents the model number of the application loaded</i></p> <p style="padding-left: 40px;"><i>wwxx – represents the configuration level</i></p> <p style="padding-left: 80px;"><i>ww represents the main board hardware compatibility level</i></p> <p style="padding-left: 80px;"><i>xx represents the software compatibility level (see below)</i></p> <p style="padding-left: 40px;"><i>yyyyyy – is a manufacturing date code</i></p> <p style="padding-left: 40px;"><i>zzz – is a unique time stamp</i></p>
<p>UPGRADE PRINTER CODE</p>	<p><i>The application version may only be updated with a configuration level of equal or lesser value than the software level; however, the printer’s software compatibility level can be increased by purchasing and entering the proper upgrade code here.</i></p>

(Continued next page)

System Settings (continued)

SET FACTORY DEFAULTS	<i>Parameters in this menu listing with the '◇' symbol are the designated defaults.</i>
SET FACTORY DEFAULTS	<p><i>Overwrite the current settings and restore to the factory defaults.</i></p> <p>Note: <i>The printer will reset automatically. ALL menu settings will be restored except the CUSTOM ADJUSTMENTS section.</i></p>
FORMAT ATTRIBUTES	<i>Affects the manner in which overlapping text and graphics are treated when the label is printed. Consult the Programmer's Manual for details.</i>
TRANSPARENT	<i>Intersecting text strings, images and bar codes will not be printed. (An odd number of overlapping objects will print.)</i>
◇XOR	<i>Intersecting text strings, images, and bar codes print on top of one another.</i>
OPAQUE	<i>Intersecting text strings, images, and bar codes are obliterated by those formatted last. Each character cell is treated as opaque.</i>
IMAGING MODE ◆	<i>Instructs the printer whether it can pre-image the label format. This selection can affect the accuracy of time-stamped labels and label throughput.</i>
◇MULTIPLE LABELS	<i>The printer images multiple labels as memory permits, achieving the fastest throughput; however if time-stamping, the time will reflect the moment the label is imaged rather than when actually printed.</i>
SINGLE LABELS	<i>The printer images the next label only after the previous label has been successfully printed; this single processing provides more accurate time-stamps with a minor cost to label throughput.</i>

(Continued next page)

System Settings (continued)

PAUSE MODE	<i>When enabled, PAUSE MODE suspends printing between each label until the PAUSE key is pressed.</i>
ENABLE	<i>Printer requires operator to press the PAUSE key after each label.</i>
✧DISABLE	<i>Printer completes label batch without pausing between labels.</i>
SECURITY ♦	<i>Provides the user with the ability to password protect all printer settings made through the operator panel.</i>
SELECT SECURITY	<i>Enable or disable the front panel menu system security lockout</i>
ENABLE	<i>Selecting this enables password protection.</i>
✧DISABLE	<i>No protection.</i>
MODIFY PASSWORD	<i>Modify the password required to access the front panel menu when security is enabled.</i>
UNITS OF MEASURE	<i>Selects the measurement system in which the system's settings are represented in the menu system and on configuration labels.</i>
METRIC	<i>Metric standard</i>
✧IMPERIAL	<i>Inch standard</i>
SELECT LANGUAGE ♦	<i>Selects the language in which the display messages and configuration label are shown. Only languages that are resident will be available.</i>
✧ENGLISH	<i>English</i>
FRENCH	<i>French</i>
GERMAN	<i>German</i>
SPANISH	<i>Spanish</i>
ITALIAN	<i>Italian</i>

4.1.5 Communications

SERIAL PORT ◆	<i>Controls serial communications port settings.</i>
BAUD RATE	<i>Determines the serial communication rate.</i>
38400	
28800	
19200	
◆9600	<i>9600 bits per second</i>
4800	
2400	
PROTOCOL	<i>Sets the flow control (handshaking) method. When selecting, consider the desired baud rate and the cable being used: RS-232 communications, at speeds greater than 9600 baud recommended to use CTS/DTR handshaking. RS-422 communications, XON/XOFF handshaking is the only appropriate method.</i>
◆BOTH	<i>Uses both handshaking methods</i>
SOFTWARE	<i>XON/XOFF</i>
HARDWARE	<i>CTS/DTR</i>
NONE	<i>No handshaking is used</i>
PARITY	<i>Sets Word parity</i>
◆NONE	<i>No parity</i>
ODD	<i>Odd parity</i>
EVEN	<i>Even parity</i>
DATA BITS	<i>Sets Word length</i>
7	<i>Seven bit Word length</i>
◆8	<i>Eight bit Word length</i>
STOP BITS	<i>Sets the number of stop bits</i>
◆1	<i>One stop bit</i>
2	<i>Two stop bits</i>
PARALLEL PORT ◆	<i>Controls parallel port settings.</i>
PORT DIRECTION	<i>Determines if messages are sent from the printer to the host via the parallel port.</i>
◆UNI-DIRECTIONAL	<i>One-way printer communication.</i>
BI-DIRECTIONAL	<i>Enables IEEE 1284 back channel operation.</i>

(Continued next page)

Communications (continued)

HOST TIMEOUT VALUE ♦ ✧10 (1-60)	<i>The number of seconds an active communications port must be idle before the printer may process data from a different port. This value is also used to “timeout” an image / label download.</i>
CONTROL CODES ♦	<i>Allows the operator to change the prefix of the commands listed in the Programmer’s Manual, as they are interpreted by the printer.</i>
✧STANDARD CODES	<i>Hex 01 = SOH command; Hex 02 = STX command</i>
ALTERNATE CODES	<i>Hex 5E = SOH command; Hex 7E = STX command</i>
FEEDBACK MODE	<i>Returns a 0x30, [RS], after each label successfully prints, and a 0x31, [US], after each batch of labels in printed.</i>
ENABLE	<i>Feedback characters are sent.</i>
✧DISABLE	<i>No feedback characters are sent.</i>

4.1.6 Diagnostics

HEX DUMP MODE	<i>Mode most commonly used to troubleshoot communications and format related problems. See Section 6.3 for details.</i>
ENABLE	<i>Prints raw ASCII data received from the host rather than executing the commands.</i>
◇DISABLE	<i>Executes and prints label formats (normal operating mode).</i>
OPTIONS TESTING	<i>Tests currently installed options</i>
TEST PRESENT SENSOR	<i>Performs a functional test of the Present Sensor circuitry.</i>
TEST CUTTER	<i>Performs a functional test of the optional cutter mechanism and circuitry.</i>
PERFORM TEST	<i>Selectable number of test cuts: 1, 10, or 100 times.</i>
TEST INPUT/OUTPUT	<i>Tests the optional GPIO (General Purpose Input / Output) port when installed.</i>
MONITOR GPIO INPUT	
TEST GPIO OUTPUT	
DOT CHECK TEST	<i>Tests the individual printhead dots (elements).</i>
PERFORM DOT CHECK	<i>Updates the dot check results by performing the dot check test.</i>
DOT CHECK RESULTS	<i>Displays the current results of the dot check test.</i>
XXXX OF YYYY TESTED GOOD	<i>Displays the ratio of dots tested which passed.</i>
INSPECT BAD DOTS	<i>Allows the user to view the individual resistances of the dots that failed.</i>
XXXX OF YYYY ZZZZ OHMS	<i>Press the forward and reverse keys to scroll through detailed results. The position of the dot is displayed on the top line. The resistance value is given on the second line.</i>

(Continued next page)

Diagnostics (continued)

SENSOR READINGS	<i>All Analog Sensor readings displayed</i>
THR TRAN RIBM 24V-> 255 255 255 255	<i>Live sensor values may be viewed. View is toggled with forward and reverse keys. Maximum values are shown here (actual values may vary) for the following: thermistor sensor, transmissive (gap) media sensor, ribbon motion sensor, 24 volt power supply sensor</i>
<- PS HD RANK 255 255 255	<i>(Continued) present sensor, head down sensor (n/a), printhead ranking resistor.</i>
RIBBON SENSOR LIMITS ◆	<i>Displays ribbon sensor ADC low and high values. A Level 2 reset is required to change these values.</i>
RIBBON ADC HIGH = 104 RIBBON ADC LOW = 070	<i>Approximate default values are shown here (actual values will vary following a Positioning Calibration; see Section 5.2).</i>

4.2 Display Messages





The printer generates and displays four different categories of information (if not in the Menu system or Quick Test Mode):

- User Prompts and Condition Messages
- Download Messages (see Section 5.7)
- Error Messages (see Section 6.2)
- Warning Messages (see Section 6.2)

4.2.1 User Prompts and Condition Messages

User Prompts indicate a required user operation. Condition Messages indicate a current printer operation or state, when outside the menu system.

User Prompts and Condition Messages:

Displayed Message	Description	Condition(s)
	The printer is trying to clear a fault condition.	Occurs when the FEED key is pressed to clear an error.
	A calibrated feed operation is being performed.	The FEED key is depressed for several seconds or during any feed operation when the printer has lost TOF.
	The CANCEL or TEST key was pressed during a batch job.	The current print batch will be cancelled if ENTER is pressed; the remaining labels will not be printed.
	Security protection is enabled on the printer. Provide the correct user-definable password to proceed.	You are attempting to enter MENU Mode; however, a password entry is required for access.



(Continued next page)

Displayed Message	Description	Condition(s)
<div style="border: 1px solid black; padding: 2px; width: fit-content;">PAUSED</div>	The printer is paused or / offline.	The printer is in a paused condition.
<div style="border: 1px solid black; padding: 2px; width: fit-content;">XXXX OF XXXX PRINTING</div>	The print job is being processed.	Batch status indication, updated with each label printed.
<div style="border: 1px solid black; padding: 2px; width: fit-content;">READY</div>	READY Mode.	Normal operating mode. The printer is ready to receive and process label formats.
<div style="border: 1px solid black; padding: 2px; width: fit-content;">REMOVE LABEL</div>	The Present Sensor option is enabled and a printed label is awaiting removal.	A label blocks the Present Sensor; remove it to continue printing.
<div style="border: 1px solid black; padding: 2px; width: fit-content;">SAVE CHANGES ENTER KEY = YES</div>	You are now exiting the menu, but have made changes to the settings of the printer. Pressing 'ENTER' will save these changes; if not, the printer will revert to previously saved settings.	Menu changes have affected the configuration of the printer. <div style="border: 1px solid black; padding: 5px; margin-top: 10px;"> <p>Note: If changes have been made that require a printer reset, the printer will automatically invoke that reset.</p> </div>
<div style="border: 1px solid black; padding: 2px; width: fit-content;">SYSTEM INITIALIZING</div>	Normal power-up / soft reset condition.	Follows the 'SYSTEM RESET IN PROGRESS' message after a reset or power-up.
<div style="border: 1px solid black; padding: 2px; width: fit-content;">SYSTEM RESET IN PROGRESS</div>	Normal power-up / soft reset condition.	Occurs when the user resets the printer via the host or Front Panel.
<div style="border: 1px solid black; padding: 2px; width: fit-content;">UNCALIBRATED</div>	The printer contains an invalid calibration.	Perform calibration to remove the condition. See Section 5.

4.3 The Quick Test Mode





This section explains the functions of the resident Quick Tests, accessible by pressing the  **TEST** key on the Front Panel.

Notes: With the exception of the Configuration Label, all Quick Test labels require 4-inch (102mm) wide media to capture all format information. When using less than full width media, change the Label Width setting to the width of the material to avoid printing on the platen (see Section 4.1.2).

During any Quick Test Label run, pressing the **ESC**  key or the  **TEST** key will abort printing.

4.3.1 Print Quality Label

The Print Quality Label provides an indication of overall print quality at a selected heat and speed setting. Consisting of fence and ladder type compliant bar codes, assorted font sizes and graphic fill patterns, its format can be used to ensure conformance, as well as visual aesthetics. To print a Print Quality Label:

- 1 Press the  **TEST** key.
- 2 Use the **FWD**  key to scroll to 'Print Quality Label'.
- 3 Use the **ESC**  key to select a quantity; see Section 4.0.3.
- 4 Press the  **TEST** key to start printing.





4.3.2 Configuration Label

Notes: To print all Configuration Label information, the media cannot be less than 2 inches wide (51mm) and the Label Width setting must match the width of the media being used (see Section 4.1.2).

The Configuration Label can vary with the application version and model of the printer.





The Configuration Label provides valuable printer database information, as detailed in Section 4.1. To print a Configuration Label:

- 1 Press the  **TEST** key.
- 2 Use the **FWD**  key to scroll to 'Print Configuration'.
- 3 Press the  **TEST** key to start printing.

CONFIGURATION DATE NOT SET PRINTER KEY: 4206-PA99-00000-444 APPLICATION VERSION: 83-2276-01A X2.06 02/04/2006 BOOT LOADER: 83-2266-01A 01.03 07/07/1998	SYSTEM SETTINGS INTERNAL MODULE 1024 KB SCALABEL FONT CACHE 112 KB SYMBOL SET PC-850 MULTILINGUAL ABSOLUTE COUNTER 4234 inches DATE NOT SET RESETTABLE COUNTER 4234 inches DATE NOT SET FORMAT ATTRIBUTES TRANSPARENT IMAGING MODE MULTIPLE LABEL PAUSE MODE DISABLE SELECT SECURITY DISABLE UNITS OF MEASUREMENT IMPERIAL LANGUAGE ENGLISH
SYSTEM INFORMATION PRINT BUFFER SIZE: 217In RAM TEST: PASS CUSTOM LANGUAGE: NONE	COMMUNICATIONS BAUD RATE 8800 BPS PROTOCOL BOTH PARITY NONE DATA BITS 8 STOP BITS 1 PORT DIRECTION BIDIRECTIONAL HOST TIMEOUT 10 SEC CONTROL CODES STANDARD CODES FEEDBACK MODE DISABLE
MEDIA SETTINGS MEDIA TYPE THERMAL TRANSFER SENSOR TYPE GAP LABEL LENGTH 04.00 inches MAXIMUM LABEL LENGTH 16.00 inches SENSOR CALIBRATION PAPER SENSOR LEVEL 160 GAP SENSOR LEVEL 46 EMPTY SENSOR LEVEL 18 SENSOR GAIN 7	DIAGNOSTICS HEX DUMP MODE DISABLE SENSOR READINGS THR TRAN RISM 24V 138 183 070 172 PS HD RAMK 007 182 178 RIBBON SENSOR LIMITS RIBBON ADC LOW 070 RIBBON ADC HIGH 104
PRINT CONTROL HEAT 10 PRINT SPEED 6.0 in/sec FEED SPEED 6.0 in/sec REVERSE SPEED 4.0 in/sec ROW OFFSET 00.04 in. COLUMN OFFSET 00.00 in. LABEL WIDTH 4.10 in. PRESENT DISTANCE 0.00 in. DARKNESS 32 ROW ADJUST 84 DOTS COLUMN ADJUST 0 DOTS PRESENT ADJUST 84 DOTS	PRINTER OPTIONS MODULES A: NOT INSTALLED B: NOT INSTALLED D: FORMATTED F: NOT INSTALLED Y: FORMATTED Z: NOT INSTALLED PRESENT SENSOR NOT INSTALLED CUTTER NOT INSTALLED

4.3.3 Quick Ribbon Test Label



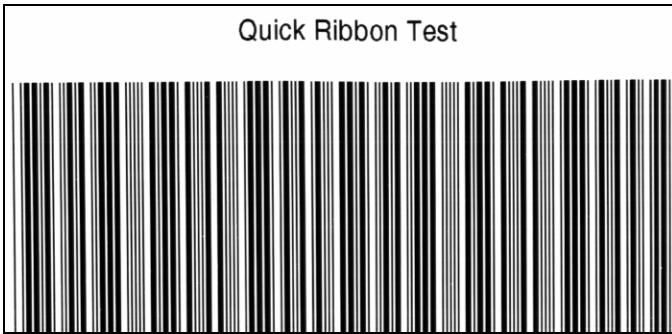

The Quick Ribbon Test Label features a compliant 4” wide, picket-fence bar code that can be used to verify ribbon and print quality functions. To print a Quick Ribbon Test Label:

- 1 Press the  **TEST** key.
- 2 Use the **FWD**  key to scroll to ‘Ribbon Test Label’.
- 3 Use the **ESC**  key to select a quantity; see Section 4.0.3.
- 4 Press the  **TEST** key to start printing.



4.3.4 Dot Test Pattern Label

The Dot Test Pattern Label tests printhead and can be used to determine the condition of each thermal element. Pattern examples are shown below. To print a Dot Test Pattern Label:

- 1 Press the  **TEST** key.
- 2 Use the **FWD**  key to scroll to 'Dot Test Pattern'.
- 3 Use the **ESC**  key to select a quantity; see Section 4.0.3.
- 4 Press the  **TEST** key to start printing.

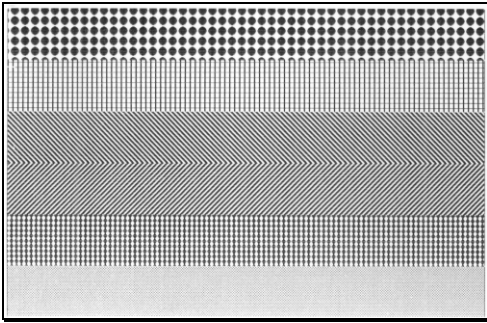

Good Test Pattern Label:

Indicates that the printhead is operating normally.

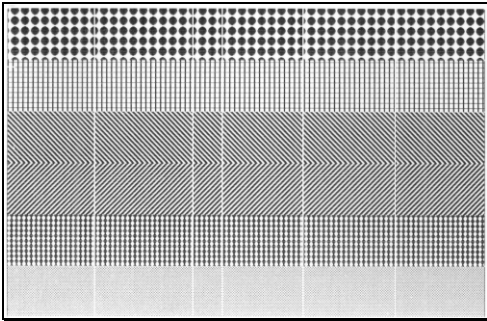





Bad Test Pattern Label:

Streaks indicate a dirty or faulty printhead. See Section 5 for cleaning instructions.

4.3.5 Validation Label

The Validation Label is another useful tool for evaluating print quality. To generate a Validation Label:

- 1 Press the  **TEST** key.
- 2 Use the **FWD**  key to scroll to 'Validation Label'.
- 3 Use the **ESC**  key to select a quantity; see Section 4.0.3.
- 4 Press the  **TEST** key to start printing.

4.3.6 User Defined Label

The User Defined Label will reprint the last label printed (unless the printer was powered-off between the printing of the last label and the request to print a user defined label). This label is recalled from the print buffer and can be any of the Quick Test labels, a label format from the host, or a label format recalled from a memory module.



Maintenance and Adjustments

Section 5

5.0 Introduction

Correct hardware adjustments, regular maintenance, and calibrations will ensure continued peak printer performance.

5.1 Media Sensor Adjustment

The laterally adjustable Media Sensor is used to detect media; it also detects label TOF for all media types, except continuous stock (where TOF is determined by the label format). To properly detect TOF, the gap, notch, or black mark must pass under the Sensor Eye Mark, as noted in the table below. If messages such as “Out-Of-Stock” or “Top-Of-Form” appear, the sensor’s position may need adjustment.

Media Sensor Adjustment		
Media Type*	Selected Sensing Method	Sensor Eye Mark Position
Standard die-cut	Gap	Near the middle of the label
Circular die-cut	Gap	Directly over the apex
Notched	Gap	Directly over the notch
Reflective	Reflective	Directly over the black mark
Continuous	Continuous	Near the middle of the label

*See Section 1.3.2 for an explanation of the media requirements.

To adjust the Media Sensor:

- 1 The printer powered ‘On’, media loaded, and the access cover open, rotate the Printhead Latch forward to raise the printhead.
- 2 After ensuring that the media is passing through the Media Sensor, position the Sensor Eye Mark over the label’s TOF mark (see drawing next page) by grasping and moving the Slide Tab ‘in’ or ‘out’.

(Continued next page)

- ③ Lower the printhead and rotate the Printhead Latch back to the locked position. Close the Access Cover.
- ④ If you are using die-cut media proceed to Step 6; otherwise, from READY mode, enter the Media Settings menu and verify that the correct 'Sensor Type' is selected for your media; see Section 4.1.1.
- ⑤ Exit the Media Settings menu and return to READY mode.
- ⑥ Press and hold the FEED key until 2-3 labels are advanced (approximately 4 seconds) to set the TOF; see Section 5.2. If 'Uncalibrated', 'Top of Form Fault', or 'Position Error, is displayed go to Section 5.3.

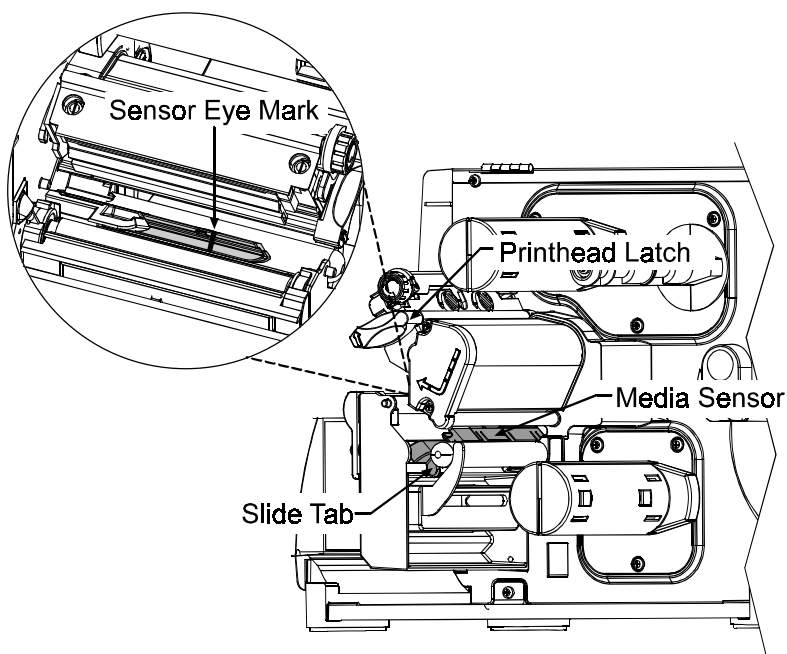

☑ **Note:** Start-of-print distance changes can be made using the Print Control/Row Adjust or Row Offset (see Section 4.1.2) or through your software labeling program.

5.2 Positioning Calibration

The Positioning Calibration sets the TOF and calculates the label length of the media. This process also calibrates the ribbon sensor on printers equipped with the thermal transfer option.

If using die-cut and reflective media, this procedure is recommended:

- 1) When a 'Position Fault' or 'Ribbon Fault' message is displayed.
- 2) After changing media.
- 3) Following a Media Sensor Calibration.

If using continuous media, TOF and label length parameters are set by the label format. So this procedure should be performed to recalibrate the ribbon sensor and is recommended:

- 1) When a 'Ribbon Fault' message is displayed.
- 2) Following a Media Sensor Calibration.

To perform a Positioning Calibration:

Step	Operator Action
1	Turn 'On' and enter the media setup parameters in the Media Settings Menu; see Section 4.1.1. (If a 'Ribbon Fault' is indicated, first perform a Level 2 reset; see Section 4.0.6.)
2	Load media (and ribbon, if equipped with the thermal transfer option); see Sections 3.2 and 3.4. Calibrate the Media Sensor; see Section 5.3.
3	Press and hold the FEED key for approximately 4 seconds or until 2-3 labels advance. Upon completion, the 'Ready' message will be displayed.

5.3 Media Sensor Calibration

Media Sensor calibration should be performed during initial printer setup, if switching media types, or if an 'Uncalibrated' message is displayed. To ensure that each label is detected correctly and reliably, two different methods are available to calibrate the printer: Standard and Advanced Entry.

5.3.1 Standard Calibration

The first calibration method is appropriate for most media types. The printhead is raised for visual access to the media; corresponding sensor readings are displayed to provide an indication of the best sensor position over the media, a







position that can become critical when using reflective or notched stock with a small TOF mark. Three required readings are:

Empty: No media in the Media Sensor.









Mark or Gap: Only the backing (liner) material, notch, or reflective mark in the sensor.

Paper: With an unmarked label area (a space without pre-printing) in the sensor.

To perform a Standard Calibration:

Step	Operator Action	Displayed Message	Comment
1	Turn 'On' the printer.	READY	Wait until 'Ready' is displayed.
2	 Press the MENU key to enter Menu Mode. Lift the printhead for visual access to the Media Sensor and load label media.	MENU MODE MEDIA SETTINGS	See Section 4.0.2 for details.
3	Press the ENT  key to enter the Media Settings menu.	MEDIA SETTINGS MEDIA TYPE	See Section 4.1.1 for details.
4	Press the FWD  key.	MEDIA SETTINGS SENSOR TYPE	See Section 4.1.1 for details.
5	Press the ENT  key. Use the FWD  key to scroll to the desired sensor type and press the ENT  key to enable the selection.	SENSOR TYPE *GAP	See Section 4.1.1 for details. The enabled selection will be indicated with an *.



(Continued next page)

Step	Operator Action	Displayed Message	Comment
6	Press the ESC  key. Use the FWD  key to scroll to 'Sensor Calibration'.		<p>See Section 4.1.1 for details.</p> <p>Press the ESC  key to abort this procedure.</p>
7	Press the ENT  key.		See Section 4.1.1 for details.
8	Press the ENT  key. Ensure no label media is in the Media Sensor then press any key.		<p>Sets the parameter for the 'out of stock' condition.</p> <p>'yyy' is a numerical value representing the current sensor reading.</p>

(Continued next page)

Step	Operator Action	Displayed Message	Comment
9	<p>Proceed according to media type:</p> <p>Die-cut stock: remove approximately six inches of label material from the backing (liner) and place the backing under the Sensor Eye Mark.</p> <p>Notched stock: place the notched area in the sensor and adjust the Sensor Eye Mark over the notch.</p> <p>Reflective media: place the black mark (face down) in the sensor and adjust the Sensor Eye Mark over the black mark.</p> <p>Press any key to continue.</p>	<div data-bbox="476 164 770 224" style="border: 1px solid black; padding: 2px;"> SCAN BACKING HIT ANY KEY <yyy> </div> <p style="text-align: center;">-OR-</p> <div data-bbox="476 310 770 370" style="border: 1px solid black; padding: 2px;"> SCAN MARK HIT ANY KEY <yyy> </div>	<p>Sets the parameter for the 'gap' or 'mark' value.</p> <p>'yyy' is a numerical value representing the current sensor reading.</p> <p>If the 'Sensor Type' is set to 'Continuous', this step is skipped, going directly into Step 10.</p>
<p><input checked="" type="checkbox"/> Note: After the Media Sensor has been adjusted do not move its position.</p>			

(Continued next page)

Step	Operator Action	Displayed Message	Comment
10	<p>Place the label (and backing) under the Sensor Eye Mark.</p> <p>Press any key to continue.</p>	<pre>SCAN PAPER HIT ANY KEY <yyy></pre>	<p>Calculates the parameter settings for the 'Paper' value.</p> <p>'yyy' is a numerical value representing the current sensor reading.</p>
11	<p>Depending upon the 'Sensor Type' selection, observe the display for the calibration message.</p>	<pre>GAP MODE CALIBRATION COMPLETE</pre> <p style="text-align: center;">-OR-</p> <pre>REFLECTIVE MODE CALIBRATION COMPLETE</pre> <p style="text-align: center;">-OR-</p> <pre>CONTINUOUS MODE CALIBRATION COMPLETE</pre>	<p>See 'Calibration Problems' (listed below) for other possible messages.</p>
12	<p>Exit upon successful calibration: press the ESC  key to back out of the menu tree, when prompted to save the settings press the ENT  key to return to the Main Menu.</p>	<pre>SAVE CHANGES? ENTER KEY = YES</pre>	<p>After saving the settings, press and hold the FEED key, approximately 4 seconds, to calibrate the label position.</p>

Calibration Problems: When problems occur during calibration, one of the following messages will be displayed. The ‘Comment’ column addresses the most likely cause and the corrective action to be taken (if any) for each situation.

Displayed Message	Action	Comment
	Press any key.	The printer measured only a small difference between the ‘empty’ and ‘gap’ readings. Transparent backing or notched type media typically gives this indication. In this case, there may be a slight delay in the ‘Out of Stock’ indication, after the media supply is emptied.

Or:

Displayed Message	Action	Comment
	Press any key.	Only a small difference or no change in low sensor readings was detected. Ensure that nothing is stuck in the media sensor. Retry calibration. If the problem persists, perform the ‘Advanced Entry Calibration’; see Section 5.3.2. If in reflective mode – REFLECTIVE MODE will be displayed instead of GAP MODE.

Or:







Displayed Message	Action	Comment
	Press any key.	Consistently high readings were received which could indicate a faulty sensor. Ensure that no labels stuck in the media sensor. Retry calibration. If the problem persists, perform the ‘Advanced Entry Calibration’; see Section 5.3.2. If in reflective mode – REFLECTIVE MODE will be displayed instead of GAP MODE.

5.3.2 Advanced Entry Calibration













The second calibration method is the Advanced Entry Calibration. This method overrides all previous settings and should be used only when the other method has failed. The procedure has two parts:

- 1) Sensor Gain: Different algorithms are used for sampling, to produce different measurements for the media.
- 2) Sensor Levels: At a selected gain, values are directly input for 'Paper', 'Mark' or 'Gap', and 'Empty' variables.



To perform an Advanced Entry Calibration:

Step	Operator Action	Displayed Message	Comment
1	Turn 'On' the printer.	READY	
2	 Press the MENU key to enter Menu Mode. Raise the printhead for visual access to the Media Sensor and media.	MENU MODE MEDIA SETTINGS	See Section 4.0.2 for details.
3	Press the ENT  key to enter the Media Settings menu.	MEDIA SETTINGS MEDIA TYPE	See Section 4.1.1 for details.
4	Press the FWD  key.	MEDIA SETTINGS SENSOR TYPE	See Section 4.1.1 for details.
5	Press the ENT  key. Use the FWD  key to scroll to the desired sensor type and press the ENT  key to enable the selection.	SENSOR TYPE *GAP	See Section 4.1.1 for details. The enabled selection will be indicated with an *.

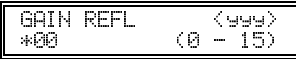

(Continued next page)

Step	Operator Action	Displayed Message	Comment
6	<p>Press the ESC  key. Use the FWD  key to scroll to 'Sensor Calibration'.</p> <p>Press the ENT  key.</p>		<p>See Section 4.1.1 for details.</p> <p>Press the ESC  key to abort this procedure.</p>
7	<p>Use the FWD  key to scroll to 'Advanced Entry'. Press the ENT  key.</p>		<p>See Section 4.1.1 for details.</p>
8	<p>Press the ENT  key.</p>		<p>See Section 4.1.1.</p>
9	<p>Place the label under the Sensor Eye Mark and lower the printhead.</p> <p>Using the FWD  key increment the Gain Number. Press the ENT  key to select the new setting and then record the sensor reading (the 'yyy' value).</p> <p>Repeat this process for each of the 16 Gain Numbers. These are the Label Values.</p>	 <p style="text-align: center;">-OR-</p> 	<p>Ensure that an unmarked label area (without pre-printing) is in the Media Sensor.</p>

(Continued next page)

Step	Operator Action	Displayed Message	Comment
10	<p>Proceed according to media type:</p> <p>Die-cut stock: remove approximately six inches of label material from the backing and place the backing under the Sensor Eye Mark. Lower the printhead.</p> <p>Notched stock: place the notched area in the sensor and adjust the Sensor Eye Mark over the notch. Lower the printhead.</p> <p>Reflective stock: place the black mark (face down) in the sensor and adjust the Sensor Eye Mark over the mark. Lower the printhead.</p> <p>After the Media Sensor has been adjusted, do not move its position.</p> <p>Using the FWD  key increment the Gain Number. Press the ENT  key to select the new setting and then record the sensor reading (the 'yyy' value). Repeat this process for each of the 16 Gain Numbers, recording each value. These are the TOF Values.</p>	<div data-bbox="473 162 780 219" style="border: 1px solid black; padding: 2px;"> GAIN TRAN <yyy> *00 (0 - 15) </div> <p style="text-align: center;">-OR-</p> <div data-bbox="473 308 780 365" style="border: 1px solid black; padding: 2px;"> GAIN REFL <yyy> *00 (0 - 15) </div>	<p>'yyy' is a numerical value representing the current sensor reading.</p>

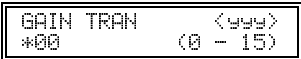



(Continued next page)

Step	Operator Action	Displayed Message	Comment
11	Using the Gain Number data collected from Steps 9 and 10, subtract each Label Value from the TOF Value. From the resulting list of Difference Values, select the largest number. Its associated Gain Number is the best selection for the media. See example below.	 <p style="text-align: center;">-OR-</p> 	<p>'yyy' is a numerical value representing the current sensor reading.</p> <p>Both sensor readings must be above 20.</p>





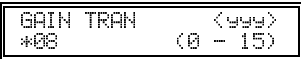



Gain Number	Label Value	TOF Value	Difference Value
00	255	254	1
01	251	240	11
02	241	213	28
03	231	182	49
04	219	150	69
05	212	119	93
06	200	88	112
07	189	58	131
08	178	32	146
09	167	20	147
10	156	17	139
11	146	16	130
12	136	15	121
13	126	15	111
14	116	14	102
15	112	14	98

Example from the data compiled in the table above:

Gain Algorithm Number 8 should be used because it has the highest difference value (146) where both label and TOF values are above 20.

Step	Operator Action	Displayed Message	Comment
12	Using the FWD  key, select the Gain Number as determined in Step 11. Press the ENT  key to enable the entry.	 <p style="text-align: center;">-OR-</p> 	When enabled, the selection will be indicated with an *.

(Continued next page)

Step	Operator Action	Displayed Message	Comment
13	<p>Using the ‘Gain Number’ set in Step 12, complete the following steps:</p> <ol style="list-style-type: none"> ❶ Place the label under the Media Sensor. Record the sensor reading and label it “P” (paper). ❷ Place the backing, mark, or notch under the Media Sensor. Record the sensor reading and label it “G” or “M” (gap or mark). ❸ Remove all media. Record the sensor reading and label it “E”. 	<div style="border: 1px solid black; padding: 2px; margin-bottom: 10px;"> GAIN TRAN <yyy> *08 (0 - 15) </div> <p style="text-align: center;">-OR-</p> <div style="border: 1px solid black; padding: 2px;"> GAIN REFL <yyy> *08 (0 - 15) </div>	‘yyy’ is a numerical value representing the current sensor reading.
14	Press the ESC  key. And then press the FWD  key.	<div style="border: 1px solid black; padding: 2px;"> ADVANCED ENTRY SENSOR LEVELS </div>	
15	<p>Press the ENT  key.</p> <p>Using the FWD  or the REV  key set the ‘Paper’ level to the value determined in the previous step. Press the ENT  key to set the entry and advance the menu.</p> <p>Repeat for the ‘Mark’ or ‘Gap’ and ‘Empty’ levels.</p>	<div style="border: 1px solid black; padding: 2px; margin-bottom: 5px;"> PAPER SENSOR LEVEL P*178 G*136 E*014 </div> <p style="text-align: center;">↓</p> <div style="border: 1px solid black; padding: 2px; margin-bottom: 5px;"> GAP SENSOR LEVEL P*178 G*32 E*014 </div> <p style="text-align: center;">-OR-</p> <div style="border: 1px solid black; padding: 2px; margin-bottom: 5px;"> MARK SENSOR LEVEL P*178 G*32 E*014 </div> <p style="text-align: center;">↓</p> <div style="border: 1px solid black; padding: 2px;"> EMPTY SENSOR LEVEL P*178 G*32 E*011 </div>	
16	Press the ESC  key to back out of the menu and then press the ENT  key to save the settings and return to the Main Menu and Ready Mode.	<div style="border: 1px solid black; padding: 2px;"> SAVE CHANGES? ENTER KEY = YES </div>	From Ready Mode, press and hold the FEED key, approximately 4 seconds, to calibrate the label position.

5.4 Printhead Adjustments

To ensure even and consistent print quality across a wide range of media types, widths and thickness, the printhead is equipped with two adjustments: the Leveling Cam and the Burn Line.

5.4.1 Leveling Cam Adjustment

The Printhead Leveling Cam raises and lowers the right side of the Printhead Assembly. Make this important adjustment when using media that is less than the full width of the Platen Roller.

- 1 Load the printer with media.
- 2 Download a label format or use a Quick Test label.
- 3 Begin printing and examine the right side of the label.
- 4 Rotate the Printhead Leveling Cam clockwise or counter-clockwise until even print is achieved across the width of the label (see examples below).

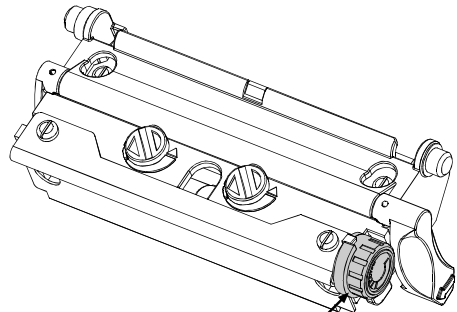

Printhead Leveling Cam

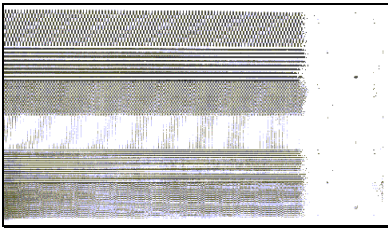

An incorrect adjustment (too much) produces a gradual fading across the label. In this case, the Printhead Leveling Cam setting should be decreased.

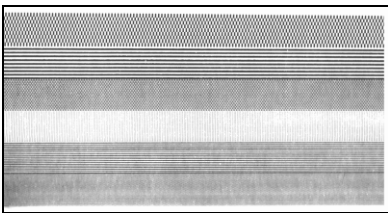

A correct adjustment produces a complete image with an even contrast across the label.

Note: An incorrect adjustment (too little) can also cause ribbon wrinkling and label tracking problems; and lead to Platen Roller and Printhead wear.

5.4.2 Burn Line Adjustment

The row of heat elements running the length of the thermal printhead is referred to as the Burn Line. At the factory, the burn line has been adjusted to meet strict print and bar code compliance requirements, using 6.5-mil (.0065") media, enabling the printer to accommodate the majority of media types in use today.

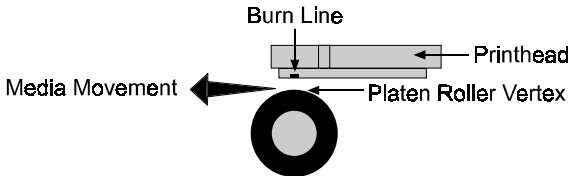

Thermal transfer models have the Burn Line positioned slightly forward of the Platen Roller vertex to allow the liquefied wax/ink to separate easily from the ribbon base film and adhere to the label while still hot. While direct thermal models have the Burn Line positioned closer to the Platen Roller vertex for more efficient heat transfer.

If media with a different thickness or rigidity is used (e.g., tag stock), a Printhead Burn Line adjustment may be needed *if* the print quality has been adversely effected. A forward adjustment will correct this. Conversely, a backward adjustment will correct for a change when using extremely thin media. To perform a Burn Line adjustment:

- 1 With the printer loaded with media (and ribbon, if thermal transfer printing), lower and rotate the Printhead Latch to the locked position.
- 2 Loosen the two Locking Screws.
- 3 Turn the Adjustment Screws counter-clockwise until the Burn Line is past the Platen Roller vertex. Print a Validation Label from the Quick Test menu. The label should look light and uneven.
- 4 Tighten the Locking Screws just until they are 'snug'— tight enough to remove any play in the printhead assembly, yet loose enough to allow the Adjustment Screws to move the printhead.

(Continued next page)

- 5 Turn each Adjustment Screws clockwise about $\frac{1}{4}$ a turn (or $\frac{1}{8}$ a turn for finer adjustments). Print another Validation Label and examine the print quality. Repeat this step until labels with even print contrast (darkness) and acceptable print quality are produced.
- 6 Tighten the Locking Screws. Print a final Quick Test label to verify the adjustment.

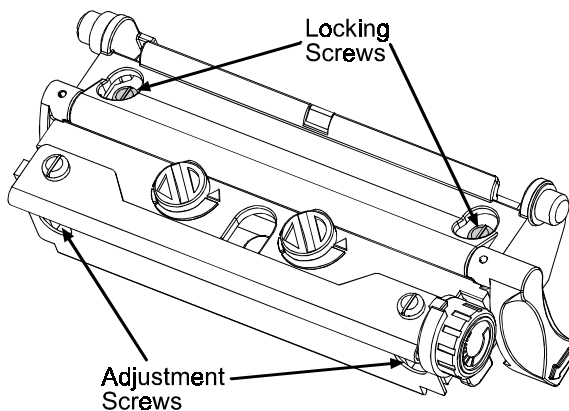

☑Note: When the Locking Screws are 'snug', turning the Adjustment Screws counter-clockwise will not move the printhead outward. If you have adjusted the printhead too far inward, restart the entire procedure.

5.5 Printhead Replacement

Locating pins in the printhead assembly eliminate the need for an alignment following the installation of a new printhead.

- ❶ Touch a metal part of the printer's frame to discharge any static electricity that may be present on your body.
- ❷ Turn 'Off' and unplug the printer. Open the Access Cover, rotate the Printhead Latch forward and raise the printhead. Remove the ribbon, if installed.
- ❸ Lower and rotate the Printhead Latch to the locked position.
- ❹ Loosen the Printhead Mounting Screw (it will remain captivated in the assembly). Rotate the Printhead Latch forward to the unlocked position.
- ❺ Raise the assembly and while carefully holding the Printhead, disconnect the two Cables and then remove the Printhead.
- ❻ While carefully holding the new Printhead, reconnect both Cables.
- ❼ Position the Printhead onto the Locating Pins in the Printhead Assembly and secure in place with the Printhead Mounting Screw. (Do not over-tighten this screw.)
- ❽ Clean the Printhead; see Section 5.6.1.
- ❾ Reload ribbon, if removed. Lower and rotate the Printhead Latch to the locked position. Plug in and turn 'On' the printer.

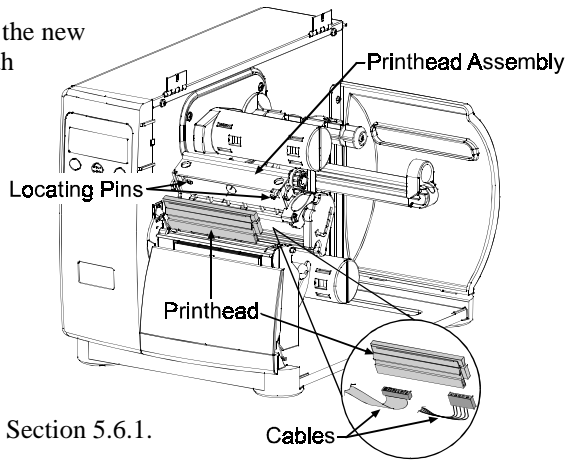
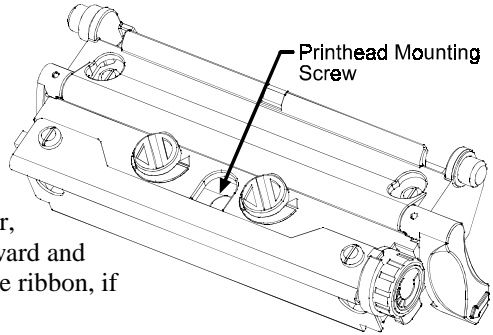

⚠️Note: The printhead is delicate. Use extreme care when handling. Never use a sharp object on the printhead surface.

5.6 Cleaning Schedule

A clean printer operates efficiently. The following list of cleaning items and table below provides the recommended schedule and technique for cleaning the various parts of your printer safely and effectively.

- Isopropyl alcohol
- Cotton swabs
- A clean, lint-free cloth
- Soft-bristle brush
- Soapy water/mild detergent
- Compressed air



CAUTION

For your continued safety and to avoid damage, always turn 'Off' and unplug the printer before cleaning.

Isopropyl alcohol is a flammable liquid; always take proper precautions when using this solvent.

Area	Cleaning Method	Cleaning Interval
Printhead	Using a cotton swab dampened with isopropyl alcohol, clean the printhead from end to end, removing all build-up. See Section 5.6.1.	Clean after each roll or box of labels.
Platen Roller	Using a cotton swab dampened with isopropyl alcohol, rotate the platen and remove all build-up. See Section 5.6.2.	Clean after each roll or box of labels.
Media Path / Tear Plate	Compressed air / soft-bristle brush and isopropyl alcohol. Remove all build-up along the path that the ribbon and paper follow through the printer.	As needed, based on a weekly visual inspection.
Media Sensor	Compressed air, isopropyl alcohol if needed. Remove all build-up.	Monthly or as needed.
Interior	Soft-brush or compressed air. Remove all build-up. See Section 5.6.3.	As needed.
Exterior	Mild detergent. Remove all build-up.	As needed.

5.6.1 Cleaning the Printhead

If print quality begins to decline, indicated by symptoms including non-compliant bar codes, print dropouts, streaking and smudging, the typical cause is debris build-up on the surface of the printhead (see Section 4.3.4). Furthermore, if this build-up is not removed it may lead to premature element failures, greatly reducing the life of the printhead. To clean the printhead:

- 1 Turn 'Off' and unplug the printer.
- 2 Open the access cover. Unlock the Printhead Latch and raise the Printhead Assembly. Move media and ribbon away as necessary.
- 3 Gently wipe away all surface build-up on the Printhead (see below) using a cotton swab moistened, not soaked, with isopropyl alcohol. Allow the printhead to dry.
- 4 Re-install ribbon and media, if removed. Lower and rotate the Printhead Latch to the locked position.
- 5 Close the cover. Plug in and turn 'On' the printer. Feed several labels to normalize tracking.

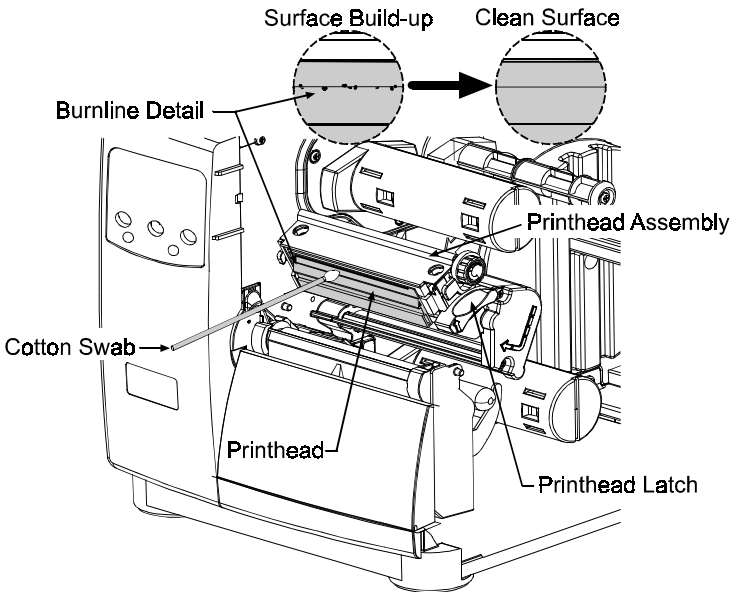

Note: NEVER use a sharp object to clean the Printhead.

5.6.2 Cleaning the Platen Roller

A platen roller contaminated with grit, label adhesive, or ink can cause a decline in print quality and, in extreme cases, even cause labels to stick and wrap around the roller. To clean the platen roller:

- ❶ Turn 'Off' and unplug the printer.
- ❷ Open the access cover. Unlock the Printhead Latch and raise the Printhead Assembly. Remove media and ribbon.
- ❸ Using a Cotton Swab dampened with isopropyl alcohol, clean the Platen Roller; manually rotate the roller and repeat, cleaning the entire surface. Allow the Platen Roller to dry.
- ❹ Replace ribbon and media.
- ❺ Lower the Printhead Assembly and lock the Printhead Latch.
- ❻ Close the access cover. Plug in and turn 'On' the printer. Feed several labels to normalize tracking.

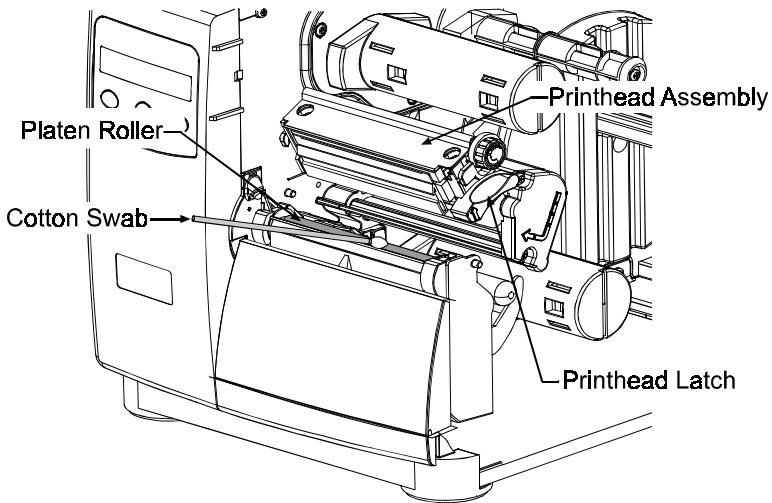

Note: NEVER use a sharp object to clean the Platen Roller.

5.6.3 Interior and Exterior Surfaces

Cleaning Interior Surfaces: During normal operation, dust particles can build-up inside the printer and find their way onto the media to cause voids in the print. To prevent this, turn 'Off' and unplug the printer. Then use a soft bristle brush or compressed air to clean the interior of the printer.

Cleaning Exterior Surfaces: The outer surfaces of the printer should be cleaned using a general-purpose cleanser. Turn 'Off' and unplug the printer. Then use a soft cloth or sponge dampened with a general-purpose cleanser to wipe the exterior surfaces clean. Never use abrasive cleansers or solvents.

5.7 Updating the Application Version

The printer stores its operating system program (Application Version) in Flash memory on the Main PCB. A feature is included to allow updates to this program through the printer's parallel port. Updates can be found on our web site. To update the application version:

- 1 Identify both application versions: confirm the current version by printing a Configuration Label. Compare that version string to those available from our web site. Download the desired program onto your computer's hard drive or a floppy disk.
- 2 Place the printer into Download Mode: press and hold the PAUSE and TEST keys simultaneously while turning the printer 'On'. The printer will first display the Boot Loader version string:

Displayed Message	Comment
	This information may vary with different printer models and Boot Loader versions.

Followed by:

	The printer is now ready to accept the new application version.
--	---

(Continued next page)

- ③ Downloading: Using the DOS copy command (where 'filename' is the program to download, e.g., 4206pa10_102.zs), enter the following:

copy filename lpt1:

Note: Printer Key hardware and software compatibility must at a minimum level to accept the file download. In the example above, the hardware compatibility level must be 'pa', while the software compatibility level must be '10' or higher; see Section 4.1.4, 'Configuration Level' for details.

After downloading starts, the following information will be displayed:

Displayed Message	Comment(s)
<pre>UPDATE SOFTWARE READING IMAGE</pre>	The printer is receiving the new download image (program).

Then:

<pre>ERASING FLASH SOFTWARE IMAGE</pre>	The program has been successfully received. The printer has verified it and is now erasing Flash memory. At this point the previous software program has been deleted from Flash memory.
---	--

And finally:

<pre>WRITING FLASH SOFTWARE IMAGE</pre>	The printer is writing the new program into Flash memory.
---	---

Upon completion, the printer will automatically reset and the new application will begin running; however, before continuing the printer must be re-calibrated; see Section 5.3.

Errors during downloading: If an error occurs during the download, the process is aborted. If this process did not reach 'Erasing Flash', the previous program is left intact; otherwise, a successful download must be completed before the printer is operable again. The following is list of possible download error messages.

(Continued next page)

Download Error Messages:

Displayed Message	Descriptions / Causes / Solutions
<pre>INVALID SOFTWARE DATA REJECTED</pre>	<p>The printer detected an error in the download. The possible causes include:</p> <ul style="list-style-type: none">• An invalid or corrupted file was downloading.• Communications error.• Application downloading was not compatible with the Printer Key hardware or software level; see Section 4.1.4, System Settings/Configuration Level.
<pre>ERROR ERASING FLASH</pre>	<p>The printer could not successfully erase Flash memory. The possible cause is defective Flash memory. Try the download again; however, if the problem continues call for service.</p>
<pre>ERROR WRITING FLASH</pre>	<p>The printer could not successfully write the program into Flash memory. The possible cause is defective Flash memory. Try the download again; however, if the problem continues call for service.</p>



Troubleshooting

Section



6.0 Introduction

If a problem arises with the printer, the information in this section will help you resolve it. Use this as a starting point in troubleshooting. If you have questions, or if problems persist, contact a qualified service technician or a Technical Support Representative.

6.1 General Troubleshooting

The following are problems that will not necessarily generate a message (see Section 6.2 for Error and Warning Messages).

If experiencing this problem...	Try this solution...
Cannot communicate through the parallel port:	Be sure the parallel cable is connected and is the correct type for the application. Try setting the 'Parallel Port Direction' to Uni-Directional; some host computers are not bi-directional compatible. See Section 4.1.5.
Display is blank, but the READY indicator is 'On':	The display contrast may set too low. Press and hold the MENU key for 10 seconds or until the display reappears.
Erratic printing (strange characters instead of label formats print):	<ul style="list-style-type: none">• The printer may be in 'hex dump mode'; see Section 6.3. Enter the Diagnostics menu and disable this mode; see Section 4.1.6. Exit the menu, save changes and return to the 'READY' mode.• If using the serial port for communicating, check both the host and printer port configuration; the printer may be set for 8 data bits while the host is set for 7 bits (or vice versa).

(Continued next page)

If experiencing this problem...	Try this solution...
Intellifont™ will not print:	Intellifont™ format is Little/Big Endian specific. The printer uses Big Endian. Refer to your font supplier for information.
Light print on the right side (facing the printer) of the label:	<ul style="list-style-type: none"> • The Printhead Leveling Cam may be incorrectly adjusted; see Section 5.1.4. • The Platen Roller may be dirty or worn; see Section 5.6.2.
Missing information in the printed label:	<ul style="list-style-type: none"> • Check the label format for character placement outside the dimensions of the label; all row/column values must allow enough space for the height/length of the characters and bar codes to be printed within the format size. • The available memory may have been exceeded by the memory requirement of the label format. Try reducing the memory allocated to either the internal module or scaleable font caches; see System Settings/Memory Settings – Section 4.1.4.
Missing print on left or right side of the label:	Information may be formatted outside the label dimensions. Check your software program label size or check the values in the menu for Print Control / Column Offset and Print Control / Custom Adjustments / Column Offset; see Section 4.1.2.

(Continued next page)

If experiencing this problem...	Try this solution...
<p>No power (all indicator lights are ‘Off’):</p>	<ul style="list-style-type: none"> • Verify that the AC power cord has been made at both the outlet and the printer; also, ensure the power switch is ‘On’. • Verify that the AC outlet is functioning, or try moving the printer to another AC circuit. • The AC cord may be damaged; replace it. • The power switch may be defective or the line fuse blown; call for service.
<p>Nothing is printing (labels advance normally, but no image is printed):</p>	<p>Examine the used ribbon for an image.</p> <p>If an image is on the used ribbon:</p> <ul style="list-style-type: none"> • Verify that the ribbon was properly loaded per Section 3.4. • If it was properly loaded, the wrong ribbon coating configuration was used. Clean the printhead (see Section 5.6.1); then replace the ribbon with one that has the coating on the correct side, per Section 3.4. <p>If no image is on the used ribbon:</p> <ul style="list-style-type: none"> • Run a Quick Test label; see Section 4.3. If an image printed, then check the protocol and port settings for both the printer and host. These must match. • The heat setting may be too low. Make an adjustment in the software program or through the Front Panel. • The media/ribbon combination may be incorrect. Contact a Media Representative. • The printhead or printhead cable(s) may be loose; power ‘Off’ and reconnect; see Section 5.5.

(Continued next page)

If experiencing this problem...	Try this solution...
Nothing happens when trying to print using a software program:	<ul style="list-style-type: none"> • Ensure that the printer is at READY. • Observe the Front Panel, if the READY light does not flash as you send the format check the protocol and port settings between the printer and host. • Ensure the I/O cable meets the requirements found in Section 3.1.1.
Poor print quality:	<ul style="list-style-type: none"> • The printhead may need cleaning; see Section 5.6.1. • Adjust these settings through the Front Panel or by host commands, Heat, Print Speed and Darkness; see Sections 2.1.1 and 4.1.2. • The media/ribbon combination may not be compatible; see Section 2.1. • The Printhead Leveling Cam may be incorrectly adjusted; see Section 5.4.1. • The Platen Roller may be dirty or worn; see Section 5.6.2. • The Printhead Burn Line may need adjusting; see Section 5.4.2.
Skips labels when printing:	<ul style="list-style-type: none"> • The printer may need calibration; see Section 5.2 and 5.3. • The Media Sensor may be slightly out of position; readjust the position; see Section 5.1. • The label format may be too close (within 1/8" of the edge) to the start of the next label. Try reducing or moving the format slightly.
Unable to print rotated text:	<ul style="list-style-type: none"> • The characters may be formatted outside the label dimensions. Ensure the row/column values provide enough room for the height of the characters or bar code to be printed. See the <i>Programmer's Manual</i> for details.

6.2 Error and Warning Messages

When the printer detects a (potential) problem, a message is displayed and an Error indicator (see Section 4.0.4) will be illuminated. There are two types of indicators:

- Error Indication – the Error indicator ‘fast flashes’ with message.
- Warning Indication – the Error indicator ‘slow flashes’ with message.

The Error and Warning Messages are listed in the following two tables, including a brief description of each and possible solution(s).

☑Note: After the printer enters an error condition, the FEED key must be pressed to clear the error.

Error Messages:

Displayed Message	Description	Possible Solution(s)
ADC FAULT	The printer has detected an analog to digital circuit converter failure.	Try cycling the printer power ‘Off’ and ‘On’. If the fault does not clear, call for service.
CUTTER FAULT	The printer has detected a cutter mechanism fault.	<div style="border: 1px solid black; padding: 5px; margin-bottom: 10px;"> <p>WARNING! Use extreme care: Turn ‘Off’ and unplug power before examining the cutter.</p> </div> <p>Make sure the cutter option is properly installed. Carefully examine the cutter for obstructions.</p>
DMA FAULT	The printer has detected a Direct Memory Access failure.	Try cycling the printer power ‘Off’ and ‘On’. If the fault does not clear, call for service.

(Continued next page)

Error Messages (continued):

Displayed Message	Description	Possible Solution(s)
<div style="border: 1px solid black; padding: 2px; width: fit-content;">OUT OF STOCK</div>	<p>The printer cannot detect media.</p>	<ol style="list-style-type: none"> 1) Reload media. 2) Ensure that the labels are passing through the Media Sensor. 3) Readjust the Media Sensor over the TOF mark; see Section 5.1. 4) Calibrate the printer; see Section 5.3.
<div style="border: 1px solid black; padding: 2px; width: fit-content;">POSITION FAULT</div>	<p>The printer has determined that the media is not correctly positioned to print.</p>	<p>Press and hold the FEED key for 4 seconds; see Section 5.2. Calibration may also be needed. See Section 5.3.</p>
<div style="border: 1px solid black; padding: 2px; width: fit-content;">PRINT ENGINE FAULT</div>	<p>The printer has detected a problem in the print logic.</p>	<p>Try cycling the printer power 'Off' and 'On'. If the fault does not clear, call for service.</p>
<div style="border: 1px solid black; padding: 2px; width: fit-content;">RAM FAULT</div>	<p>The system has detected a RAM failure.</p>	<p>Try cycling the printer power 'Off' and 'On'. If the fault does not clear, call for service.</p>

(Continued next page)

Error Messages (continued):

Displayed Message	Description	Possible Solution(s)
<div style="border: 1px solid black; padding: 2px; width: fit-content;">RIBBON FAULT</div>	<p>The ribbon sensor detects no or only sporadic ribbon supply hub movement; or the sensor values may have changed.</p> <div style="border: 1px solid black; padding: 5px; margin-top: 10px;"> <p><input checked="" type="checkbox"/> Note: The ribbon sensor calibration can be performed only after a Level 2 reset has cleared the previously entered values.</p> </div>	<ol style="list-style-type: none"> 1) Ensure that ribbon is correctly loaded with the printhead locked down. 2) Check the ribbon supply and ribbon take up hubs for obstructions stopping movement. 3) Ensure that the ribbon supply core fits snugly on the ribbon supply hub. 4) Ensure that the media and paper combination is correct. 5) Perform a Level 2 Reset (Section 4.0.6) and then a Positioning Calibration (Section 5.2).
<div style="border: 1px solid black; padding: 2px; width: fit-content;">STROBE TIMING FAULT</div>	<p>The printer has detected a problem applying the printhead heat strobe.</p>	<p>Try cycling the printer power ‘Off’ and ‘On’. If the fault does not clear, call for service.</p>
<div style="border: 1px solid black; padding: 2px; width: fit-content;">TEMPERATURE FAULT</div>	<p>The printer has shutdown to allow the printhead temperature to cool.</p>	<p>Turn ‘Off’ the printer until cool to prevent permanent damage due to an excessive printhead temperature.</p>

(Continued next page)

Error Messages (continued):



Displayed Message	Description	Possible Solution(s)
<div style="border: 1px solid black; padding: 2px; text-align: center;">TOP OF FORM FAULT</div>	<p>The printer could not find the TOF mark within the maximum label length setting or it found a TOF in an unexpected place.</p>	<p>If media is moving:</p> <ol style="list-style-type: none"> 1) Press the FEED key. It may be necessary to re-calibrate the printer; see Section 5.3. 2) The Media Sensor may be out of position. Readjust its position; see Section 5.1. 3) The media may not be properly loaded. Reload media and ensure that the Media Guide is positioned properly; see Section 3.2. 4) The label may be longer than the default value for maximum length. Check the Media Settings / Maximum Label Length; see Section 4.1.1. 5) The Media Sensor may be obstructed. Check and carefully remove any obstruction (labels, paper dust, adhesive, etc). <p>If media is not moving:</p> <p>The printhead may not be latched; close and lock the printhead.</p>
<div style="border: 1px solid black; padding: 2px; text-align: center;">24V OUT OF TOLERANCE</div>	<p>The printer has detected a drop in the 24 volt power supply.</p>	<p>Try cycling the printer power 'Off' and 'On'. If the fault does not clear, call for service.</p>

Warning Messages:

Displayed Message	Description	Action
DOT FAILURE	The printer has detected burned-out printhead elements.	Replace the printhead when print quality degrades or if bar codes are non-compliant.
GAP MISSED	The printer missed detecting a label gap.	Readjust the media sensor and recalibrate.
GOODBYE	Power has been removed and shutdown is in progress.	The printer power switch was turned 'Off', the line fuse has blown, or AC line voltage has been lost.
HOST CHANGES PENDING	The host has pending configuration changes that will not take effect until a 'host reset command' is issued.	To save changes, send a host reset command (in DPL) or to discard changes perform a front panel reset; see Section 4.0.1.
LOW VOLTAGE	The printer has detected a low operating voltage.	Possible low or fluctuating line voltage level. If this condition persists, try moving the printer to another outlet circuit or contact your utility company.
RIBBON LOW	Ribbon will soon need replacement.	Replace ribbon when needed.
RTC RAM FAILURE	The printer was unable to save settings in permanent memory.	If the condition persists, possible faulty Main PCB. Call for service.

(Continued next page)

Warning Messages (continued):

Displayed Message	Description	Action
	A high printhead temperature has been detected.	Allow printhead to cool.
	The previous warning condition has been corrected.	No further action is necessary.

6.3 Hex Dump Mode

The hex dump mode is a useful tool for diagnosing problems, including communication and DPL™ syntax errors, allowing a comparison of input strings (sent by host) to output data (received by printer). To decode this information, the *Programmer's Manual* is an essential reference. This output can be used for debugging the label format. And by repeatedly sending a format, this mode can uncover handshaking problems (if they exist). Handshaking problems are identified by sections of missing data in the character string.

To begin, go to the Diagnostics menu and enable Hex Dump Mode; see Section 4.1.6. Exit the menu, save changes and returning to the 'READY' mode. Now all data sent to the printer will now be output in hexadecimal code, along with the printable ASCII equivalents.

The figure below is a sample Hex Dump Label. After sending a label format to the printer, the hex code output will be immediate. As a final note, many of today's software programs use bit mapping to construct the label, making diagnosis difficult. Contact a Technical Support Representative with any questions.

```
0000 02 4C 00 44 31 31 00 31 ^L.D11.1
0008 36 31 31 30 30 30 33 61100003
0010 32 30 30 30 31 30 46 4F 200010FO
0018 4E 54 20 36 3A 20 41 4C NT 6: AL
0020 4C 20 56 41 4C 49 44 20 L VALID
0028 20 20 20 20 20 20 20
0030 20 20 20 00 31 36 31 31 1611
0038 30 30 30 30 32 38 30 30 00002800
0040 30 31 30 20 20 20 20 010
0048 20 20 20 43 48 41 52 41 CHARA
0050 43 54 45 52 53 3A 00 31 CTERS: 1
0058 36 31 31 30 30 30 32 61100002
0060 34 30 30 30 31 30 23 24 400010#$
0068 25 26 28 29 2A 2B 2C 2D %&()*+,-
```

Note: To exit the hex dump mode, re-enter the Diagnostics menu / Hex Dump Mode and select 'Disable'. Exit the menu, save changes and return to the 'READY' mode.



Specifications

Section

7.0 Printer Specifications

Bar Codes

(See the *Programmer's Manual* for details. See Appendix B for visual samples.)

Code 39, Interleaved 2 of 5, Code 128 (subsets A, B and C), Codabar, LOGMARS, UPC-A, UPC-E, UPC 2 & 5 digit addendums, EAN-8, EAN-13, EAN 2 & 5 digit addendums, UPC Random Weight, Code 93, Plessey, Universal Shipping Container Symbology, Code 128 MOD 43, Postnet, USS/EAN-128 Random Weight, Telepen, UPS MaxiCode (modes 2 & 3), PDF417, Data Matrix.

Fonts

9 Bit-Mapped Fonts, rotatable 0, 90, 180, 270 degrees

CG Triumvirate™ Scalable Font

CG Triumvirate™ Condensed Bold Scalable Font

Communications

Interface	EIA RS-232/DB-25 Serial, and IEEE 1284 Compliant Parallel
Baud Speed	2400, 4800, 9600, 19.2K, and 38.4K baud.
Handshaking	Xon/Xoff; CTS/DTR
Parity	Even, Odd, or None
Stop Bits	1 or 2
Data Bits	7 or 8

Electrical

Input Voltage: 90 – 132 or 180 – 264 VAC @ 47–63 Hz, auto-ranging.

Power Consumption: Typical Operating: 90 Watts / Standby: 10 Watts

Grounding: Unit must be connected to a properly grounded receptacle.

Environmental Requirements

Operating Temperature:	32° F – 100° F (0° C to 38° C)
Storage Temperature:	0° F –140° F (-17° C to 60° C)
Humidity:	10% – 95% non-condensing
Dust:	Non-conducting, non-corrosive
Electromagnetic Radiation:	Moderate RF fields can be tolerated

Mechanical

Height:	12.70" (322.6mm)
Width:	12.62" (320.6mm)
Depth:	18.60" (472.5cm)
Weight:	45 lbs. (20.5 kg)

Printing Specifications

Printing Type:	Direct Thermal or optional Thermal Transfer
Print Speed:	2 – 6 IPS (50.8 – 152.4 mmps) <i>2461</i> 2 – 8 IPS (50.8 – 203.2 mmps) <i>3481</i>
Printhead Resolution:	203 DPI (8 dots/mm) <i>2461</i> 300 DPI (11.8 dots/mm) <i>3481</i>
Nominal Dot Size:	.0043" X .0052" (.109mm X .132mm) <i>2461</i> .00027" X .0043" (.069mm X .108mm) <i>3481</i>
Printhead Protection Type:	Thermistor Sensor. Sensing of an over-temperature condition causes shutdown; printing resumes automatically after cooling.
SDRAM Memory:	8 MB <i>2461</i> 16 MB <i>3481</i>
Flash Memory:	1 MB <i>2461</i> 2 MB <i>3481</i>
Maximum Print Width:	4.09" (103.9 mm) <i>2461</i> 4.16" (105.6 mm) <i>3481</i>
Print Length Range:	.25" – 99" (6.35mm – 2514.6mm)
Print Justification:	Left

Media and Ribbon

- Media Types: Roll-Fed, Die-Cut, Continuous, Fan-Fold. Flat on the printable side with no more than .0007" (.018mm) protrusions on the opposite side.
- Maximum Media Width: 4.65" (118.1 mm)
- Minimum Media Width: 1" (25.4 mm)
- Media Thickness: .0025" - .01" (.06 mm – .25 mm)
- Media Roll Capacity*: 8" (203.2 mm) Outer Diameter
- Media Core: 1.5" or 3.0" (38 mm – 76.2 mm) Inner diameter
- Ribbon Core: 1.010 ± .006" (25.65 ± .15 mm) Inner diameter size. Core not to protrude beyond ribbon edge.
- Ribbon Width Range**: 1.0 – 4.5" (25.4 – 114.3 mm)
- Ribbon Length**: 1968 Feet (600 Meters) Maximum

*Labels wound out only.

**Coated side in or out depending upon the Ribbon Supply Hub in the printer; the ribbon width to slightly exceed label width (including backing material).

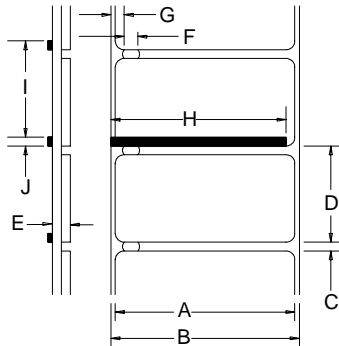

Designator	Description	Max.*	Min.*
A	Label width:	4.65	1.00
B	Backing width:	4.65	1.00
C	Gap between labels	.250	.100
D	Label length	99.99	.250
E	Media thickness	.0100	.0025
F	Width of sensor opening	.500	.200
G	Distance from the media edge to the Media Sensor opening edge (left justified)	2.250	.200
H	Reflective sensor mark width**	4.65	.500
I	Distance between reflective mark	99.99	.500
J	Reflective sensor mark length	.250	.100

*Units of measure are in inches.

**The reflective sensor black mark must be carbon based and placed on the backside of the stock. The reflectance of the mark shall be less than 10% at wavelengths of 950 and 640 nm.

Approved Media

To achieve optimum print quality and maximum printhead life, we recommend the use of *our* media and ribbons. These supplies are specially formulated for use in our printers; use of other supplies may affect the print quality, performance, and life of the printer or its components.

For a current list of approved media and ribbons for use in direct thermal and thermal transfer applications consult Section 2.1.1 or contact a Media Representative.



Appendix A

ASCII Control Code Chart

	Char	Dec	Hex	Char	Dec	Hex	Char	Dec	Hex	Char	Dec	Hex
Ctrl @	NUL	0	00		32	20	@	64	40	`	96	60
Ctrl A	SOH	1	01	!	33	21	A	65	41	a	97	61
Ctrl B	STX	2	02	“	34	22	B	66	42	b	98	62
Ctrl C	EXT	3	03	#	35	23	C	67	43	c	99	63
Ctrl D	EOT	4	04	\$	36	24	D	68	44	d	100	64
Ctrl E	ENQ	5	05	%	37	25	E	69	45	e	101	65
Ctrl F	ACK	6	06	&	38	26	F	70	46	f	102	66
Ctrl G	BEL	7	07	·	39	27	G	71	47	g	103	67
Ctrl H	BS	8	08	(40	28	H	72	48	h	104	68
Ctrl I	HT	9	09)	41	29	I	73	49	i	105	69
Ctrl J	LF	10	0A	*	42	2A	J	74	4A	j	106	6A
Ctrl K	VT	11	0B	+	43	2B	K	75	4B	k	107	6B
Ctrl L	FF	12	0C	,	44	2C	L	76	4C	l	108	6C
Ctrl M	CR	13	0D	-	45	2D	M	77	4D	m	109	6D
Ctrl N	SO	14	0E	.	46	2E	N	78	4E	n	110	6E
Ctrl O	SI	15	0F	/	47	2F	O	79	4F	o	111	6F
Ctrl P	DLE	16	10	0	48	30	P	80	50	p	112	70
Ctrl Q	DC1	17	11	1	49	31	Q	81	51	q	113	71
Ctrl R	DC2	18	12	2	50	32	R	82	52	r	114	72
Ctrl S	DC3	19	13	3	51	33	S	83	53	s	115	73
Ctrl T	DC4	20	14	4	52	34	T	84	54	t	116	74
Ctrl U	NAK	21	15	5	53	35	U	85	55	u	117	75
Ctrl V	SYN	22	16	6	54	36	V	86	56	v	118	76
Ctrl W	ETB	23	17	7	55	37	W	87	57	w	119	77
Ctrl X	CAN	24	18	8	56	38	X	88	58	x	120	78
Ctrl Y	EM	25	19	9	57	39	Y	89	59	y	121	79
Ctrl Z	SUB	26	1A	:	58	3A	Z	90	5A	z	122	7A
Ctrl [Esc	27	1B	;	59	3B	[91	5B	{	123	7B
Ctrl \	FS	28	1C	<	60	3C	\	92	5C		124	7C
Ctrl]	GS	29	1D	=	61	3D]	93	5D	}	125	7D
Ctrl ^	RS	30	1E	>	62	3E	^	94	5E	~	126	7E
Ctrl _	US	31	1F	?	63	3F	_	95	5F		127	7F

(Continued next page)

Char	Dec	Hex	Char	Dec	Hex	Char	Dec	Hex	Char	Dec	Hex
Ç	128	80	á	160	A0		192	C0	Ó	224	E0
ü	129	81	í	161	A1		193	C1	ß	225	E1
é	130	82	ó	162	A2		194	C2	Ô	226	E2
â	131	83	ú	163	A3		195	C3	Õ	227	E3
ä	132	84	ñ	164	A4		196	C4	ö	228	E4
à	133	85	Ñ	165	A5		197	C5	Ö	229	E5
ã	134	86	a	166	A6	ã	198	C6	μ	230	E6
ç	135	87	°	167	A7	Ã	199	C7	ρ	231	E7
ê	136	88	ı	168	A8		200	C8	ρ	232	E8
è	137	89	®	169	A9		201	C9	Ů	233	E9
è	138	8A		170	AA		202	CA	Ů	234	EA
ï	139	8B	1/2	171	AB		203	CB	Û	235	EB
î	140	8C	1/4	172	AC		204	CC	ÿ	236	EC
ì	141	8D	ı	173	AD		205	CD	Υ	237	ED
Ä	142	8E		174	AE		206	CE		238	EE
Å	143	8F	–	175	AF		207	CF		239	EF
É	144	90		176	B0	Ò	208	D0		240	F0
Æ	145	91		177	B1	D	209	D1	±	241	F1
Æ	146	92	2	178	B2	È	210	D2		242	F2
ô	147	93	3	179	B3	Ë	211	D3	3/4	243	F3
ö	148	94	´	180	B4	È	212	D4		244	F4
ò	149	95	Á	181	B5		213	D5		245	F5
û	150	96	À	182	B6	Í	214	D6	÷	246	F6
ù	151	97	À	183	B7	İ	215	D7	,	247	F7
ÿ	152	98	©	184	B8	İ	216	D8	°	248	F8
Ö	153	99	1	185	B9		217	D9	¨	249	F9
Û	154	9A		186	BA		218	DA	.	250	FA
Ø	155	9B	»	187	BB		219	DB		251	FB
£	156	9C		188	BC		220	DC		252	FC
Ø	157	9D	€	189	BD		221	DD		253	FD
x	158	9E	¥	190	BE	İ	222	DE		254	FE
f	159	9F		191	BF		223	DF	€	255	FF



Appendix B

Available Fonts and Bar Codes

All character fonts and bar codes available with the printer are described in this section. Each font and bar code has a name associated with it for use in programming. Human-readable fonts have numeric names, while bar code fonts have alpha names. Consult the *Programmer's Manual* for detailed information.

Fonts

Fonts 0 through 8 use the slash zero (Ø) convention for distinguishing between the number zero and the letter O. The slash can be removed with the 'Z' label-formatting command. These fonts are non-proportional (monospaced); each character takes the same amount of space for printing.

The Triumvirate font number 9 is a proportional font; each character will take up a different amount of space when printed.

Font	Valid ASCII Characters
0	32-127
1	32-168, 171, 172, 225
2	32-168, 171, 172, 225
3	32, 35-38, 40-58, 65-90, 128, 142-144, 146, 153, 154, 156, 157, 165, 168, 225
4	32, 35-38, 40-58, 65-90, 128, 142-144, 146, 153, 154, 156, 157, 165, 168, 225
5	32, 35-38, 40-58, 65-90, 128, 142-144, 146, 153, 154, 156, 157, 165, 168, 225
6	32, 35-38, 40-58, 65-90, 128, 142-144, 146, 153, 154, 156, 157, 165, 168, 225
7	32-126
8	32, 48-57, 60, 62, 67, 69, 78, 83, 84, 88, 90
9	32-126, 128-169, 171-173, 181-184, 189, 190, 198, 199, 208-216, 222, 224-237, 241, 243, 246-250

The table below lists the font sizes; the numbers indicate the number of dots.

FONT	HEIGHT	WIDTH	SPACING
Font 0	7	5	1
Font 1	13	7	2
Font 2	18	10	2
Font 3	27	14	2
Font 4	36	18	3
Font 5	52	18	3
Font 6	64	32	4
Font 7	32	15	5
Font 8	28	15	5

Font 0 96-character alphanumeric, upper and lower case.

```
Font 0
!"#$%&'()*+,-./
0123456789:;<=>?@
ABCDEFGHIJKLMNPO
QRSTUVWXYZ[\]^_`
abcdefghijklmnopqrstuvwxyz
!@#$%^&*~
```

Font 1 145-character upper and lower case alphanumeric w/ descenders and ascenders.

```
Font 1:
!"#$%&'()*+,-./0123456789:;<=>?@
ABCDEFGHIJKLMNPOQRSTUVWXYZ[\]^_`
abcdefghijklmnopqrstuvwxyz
CüéääååçèèëïïjIAAEæffóó
üýöÜøŁł×fa iouñÑªº¼½¾
```

Font 2 138-character alphanumeric, upper and lower case.

```
Font 2:
!"#$%&'()*+,-./0123456789:;<=>?@
ABCDEFGHIJKLMNPOQRSTUVWXYZ[\]^_`
abcdefghijklmnopqrstuvwxyz
CüéääååçèèëïïjIAAEæffóó
üýöÜøŁł×fa iouñÑªº¼½¾
```

Font 3 62-character alphanumeric, uppercase.

```
Font 3:
!"#$%&'()*+,-./0123456789:
ABCDEFGHIJKLMNPOQRSTUVWXYZ
CÆÉÖÜŁłÑªº¼
```

Font 4 62-character
alphanumeric, uppercase.

FONT 4:
#%&()*+ . - /0123456789:
ABCDEFGHIJKLMN OPQRSTU VWXYZ
ÇÀÁÈÖÜ£ØÑ¿ß

Font 5 62-character
alphanumeric, uppercase.

FONT 5:
#%&()*+ . - /0123456789:
ABCDEFGHIJKLMN OPQRSTU VWXYZ
ÇÀÁÈÖÜ£ØÑ¿ß

Font 6 62-character alphanumeric, uppercase.

FONT 6:
#%&()*+ . - /
0123456789:
ABCDEFGHIJKLM
NOPQRSTUVWXYZ
ÇÀÁÈÖÜ£ØÑ¿ß

Font 7 OCR-A, size I.

Font 8 OCR-B, size III.

Font 7:
 ! " # \$ % & ' () * + , - . /
 0 1 2 3 4 5 6 7 8 9 : ; < = > ? @
 A B C D E F G H I J K L M N O
 P Q R S T U V W X Y Z [\] ^ _ `
 a b c d e f g h i j k l m n o
 p q r s t u v w x y z { | } ~ ¯

Font 8:
 0 1 2 3 4 5 6 7 8 9
 < > C E N S T X Z I

Font 9 Internal Triumvirate font.

Point sizes are selected by the number in the bar code height. Larger point sizes can be obtained by increasing the height and width multipliers.

4 pt ABCDEFGHIJKLMNOPQRSTUVWXYZabcdefghijklmnopqrstuvwxyz0123456789
 5 pt ABCDEFGHIJKLMNOPQRSTUVWXYZabcdefghijklmnopqrstuvwxyz0123456789
 6 pt ABCDEFGHIJKLMNOPQRSTUVWXYZabcdefghijklmnopqrstuvwxyz0123456789
 8 pt ABCDEFGHIJKLMNOPQRSTUVWXYZabcdefghijklmnopqrstuvwxyz01234
 10 pt ABCDEFGHIJKLMNOPQRSTUVWXYZabcdefghijklmnopqrstuvwxyz0123456789
 12 pt ABCDEFGHIJKLMNOPQRSTUVWXYZabcdefghijklmnopqrstuvwxyz0123456789
 14 pt ABCDEFGHIJKLMNOPQRSTUVWXYZ
 18 pt ABCDEFGHIJKLMNOPQRST
 24 pt ABCDEFGHIJKLMNOP
 30 pt ABCDEFGHIJK
 36 pt ABCDEFGH
 48 pt ABCDE
 72 pt AB

Bar Code Summary Data

Bar Code fonts have alpha names (left column in the table below). Uppercase alpha names will print barcodes with human-readable interpretations. Lowercase alpha names will print barcodes only.

Barcode ID	Type	Length	Checksum	Valid ASCII Characters, decimal value representation
A	Code 3 of 9	Varies	No	32, 36, 37, 42, 43, 45-57, 65-90
B	UPC-A	11	Yes	48-57 Numeric only. Option V used in the 6th & 7th position
C	UPC-E	6	Yes	48-57 Numeric only
D	Interleaved 2 of 5 (I 2 of 5)	Varies	No	48-57 Numeric only
E	Code 128	Varies	M-103	32-127
F	EAN-13	12	Yes	48-57 Numeric only. Option V used in the 7th & 8th position
G	EAN-8	7	Yes	48-57 Numeric only
H	HBIC	Varies	M-43	32, 36-39, 42, 43, 45-57, 65-90
I	Codabar	Varies	No	36, 43, 45-58, 65-68
J	Interleaved 2 of 5 with a modulo 10 checksum	Varies	M-10	48-57 Numeric only
K	Plessey	Up to 14	M-10	48-57 Numeric only. Option + is Last Character for Second M-11 Checksum
L	Interleaved 2 of 5 with a modulo 10 checksum & shipping bearer bars	13	M-10	48-57 Numeric only
M	2 digit UPC addendum	2	Yes	48-57 Numeric only
N	5 digit UPC addendum	5	Yes	48-57 Numeric only
O	Code 93	Varies	No	35-38, 42-58, 65-90, 97-122
p	Postnet	Varies	Yes	48-57 Numeric only
Q	UCC/EAN Code 128	19	Yes	48-57 Numeric only
R	UCC/EAN Code 128 K-Mart NON EDI barcode	18	Yes	48-57 Numeric only
S	UCC/EAN Code 128 Random Weight	34 +	Yes	48-57 Numeric only
T	Telepen	Varies	Yes	Alphanumeric
U	UPS MaxiCode	84	Yes	Alphanumeric
v	FIM	1	No	A, B, C, D
z	PDF-417	Varies	Yes	All
W1c	DataMatrix	Varies	Yes	All 8-bit values



0123456789

Bar Code A Code 3 of 9

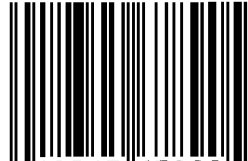

0 12345 67890 5

Bar Code B UPC-A

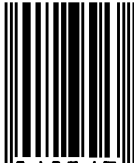

0 012345 7

Bar Code C UPC-E



0123456790

Bar Code D Interleaved 2 of 5



01234567890

Bar Code E Code 128



0 123456 7890 12

Bar Code F EAN-13



0 123 4565

Bar Code G EAN-8



+012345678900

Bar Code H Health Industry Bar
Code (HBIC)



Bar Code I Codabar



Bar Code J Interleaved 2 of 5
w/module 10 checksum



Bar Code K Plessey



Bar Code L Interleaved 2 of 5
w/module 10 checksum and
shipping bearer bars



Bar Code M 2 Digit UPC
addendum

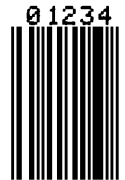

Bar Code N 5 Digit UPC addendum



Bar Code O Code 39



Bar Code p Postnet

(01) 2 3456789 012345678 9

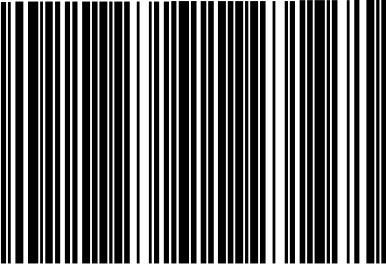

Bar Code Q UCC/EAN Code 128

34 567890 123 4567

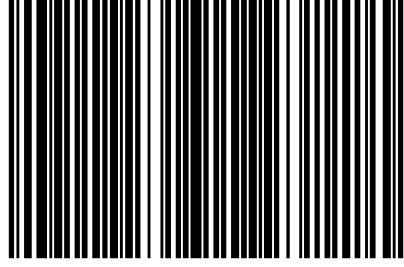

Bar Code R UCC/EAN Code 128
KMART NON EDI

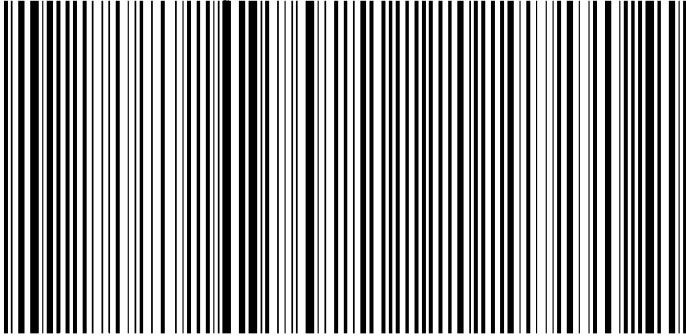

01 10073675029260 11 930420 3202 001800 21 10123456

Bar Code S UCC/EAN Code 128 Random Weight

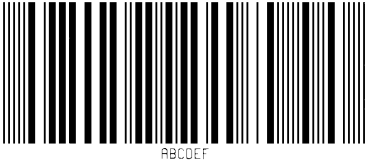

Barcode T Telepen

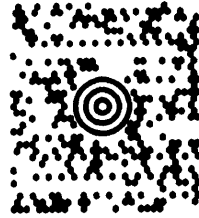

Barcode u UPS MaxiCode



Barcode v FIM



Barcode z PDF-417

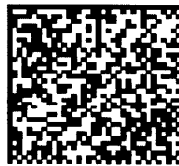

Barcode W1c DataMatrix



Appendix C

Module Assignments

Consult the *Programmer's Manual* for detailed programming information.

Module Designator	Module
D	Internal SDRAM (in 1KB blocks) 2461: 100-8192; 3481:100-16384
F	Optional User Flash
Y	Internal Flash
Z	Optional ILPC protected Flash

Print Resolutions and Maximum Widths

Printhead Resolutions and Widths				
Model	Printhead Resolution	Maximum Print Width		Factory Default Setting
		Inches	Millimeters	
2461	203 dots/inch (8 dots/mm)	4.09	103.9	4.10
3481	300 dots/inch (11.8 dots/mm)	4.16	105.6	4.16

Speed Settings and Defaults

Consult the *Programmer's Manual* for detailed information.

2461				
Function	Speed Range		Default Setting	
	IPS	MMPS	IPS	MMPS
Print	2-6	50.8 – 152.4	6.0	152.4
Feed	2-6	50.8 – 152.4	6.0	152.4
Reverse	2-6	50.8 – 152.4	4.0	101.6

3481				
Function	Speed Range		Default Setting	
	IPS	MMPS	IPS	MMPS
Print	2-8	50.8 – 203.2	6.0	152.4
Feed	2-8	50.8 – 203.2	6.0	152.4
Reverse	2-6	50.8 – 152.4	4.0	101.6



Warranty Information

Brady Products Limited Warranty Statement

Bradyprinter Models 2461 and 3481

Printer

Brady warrants to Purchaser that under normal use and service, the 2461, 3481 and 6441 Printers, (with the exception of the thermal printhead) purchased hereunder shall be free from defects in material and workmanship for a period of (365) days from the date of shipment by Brady.

Expendable and/or consumable items or parts such as lamps, fuses, labels and ribbons are not covered under this warranty. This warranty does not cover equipment or parts which have been misused, altered, neglected, handled carelessly, or used for purposes other than those for which they were manufactured. This warranty also does not cover loss, damages resulting from accident, or damages resulting from unauthorized service.

Thermal Printhead

This warranty is limited to a period of one year, (365 days), or 1,000,000 linear inches of use, whichever comes first, for the 2461, 3481 or 6441 thermal printhead. This one year (365 days) warranty is valid only if a Brady - approved thermal label media is used, as defined in the then current Brady list of approved thermal/thermal transfer media, a copy of which is available from Brady. Failure to use Brady-approved media is justification for invalidation of this thermal printhead warranty. This warranty does not cover printheads which have been misused, altered, neglected, handled carelessly, or damaged due to improper cleaning or unauthorized repairs.

Warranty Service Procedures

If a defect should occur during the warranty period, the defective unit shall be returned, freight and insurance prepaid, in the original shipping containers, to Brady at: 6555 W. Good Hope Road, Milwaukee, Wisconsin, 53223. A Return Material Authorization (RMA) number must be issued before the product can be returned. To open an RMA please call the Brady Customer Service Department at 1-800-537-8791. Please include your RMA number on the outside of the box and on the shipping document. Include a contact name, action desired, a detailed description of the problem(s), and examples when possible with the defective unit. Brady shall not be responsible for any loss or damages incurred in shipping. Any warranty work to be performed by Brady shall be subject to Brady's confirmation that such product meets Brady warranty. In the event of a defect covered by its warranty, Brady will return the repaired or replaced product to the Purchaser at Brady's cost.

With respect to a defect in hardware covered by the warranty, the warranty shall continue in effect until the end of the original warranty period, or for sixty (60) days after the repair or replacement, whichever is later.

General Warranty Provisions

Brady makes no warranty as to the design, capability, capacity or suitability of any of its hardware, supplies, or software.

Software is licensed on an “as is” basis without warranty. Except and to the extent expressly provided in this warranty and in lieu of all other warranties, there are no warranties, expressed or implied, including, but not limited to, any warranties of merchantability or fitness for a particular purpose.

Purchaser shall be solely responsible for the selection, use, efficiency and suitability of Brady’s products.

Limitation of Liability

In no event shall Brady be liable to the purchaser for any indirect, special or consequential damages or lost profits arising out of or relating to Brady’s products, or the performance or a breach thereof, even if Brady has been advised of the possibility thereof. Brady’s liability, if any, to the purchaser or to the customer of the purchaser hereunder shall in no event exceed the total amounts paid to Brady hereunder by the purchaser for a defective product.

In no event shall Brady be liable to the purchaser for any damages resulting from or related to any failure or delay of Brady in the delivery or installation of the computer hardware, supplies or software or in the performance of any services.

Some states do not permit the exclusion of incidental or consequential damages, and in those states the foregoing limitations may not apply. The warranties here give you specific legal rights, and you may have other legal rights which vary from state to state.

Glossary of Terms

alphanumeric Consisting of alphabetic, numeric, punctuation and other symbols.

backing material The silicon-coated paper carrier material to which labels with adhesive backing are affixed. Also referred to as “liner”.

bar code A representation of alphanumeric information in a pattern of machine-readable marks. The basic categories are divided into one-dimensional (UPC, Code 39, Postnet, etc.) and two-dimensional barcodes (Data Matrix, MaxiCode, PDF417, etc.).

boot loader Program resident in Flash memory that starts operations.

calibration The process through which sensor readings are entered into the printer for correct sensor function (e.g., detection of a given media).

character set The entire complement of alphanumeric symbols contained in a given font.

checksum An alphanumeric error detection method used in many bar code symbologies for informational security.

continuous media An uninterrupted roll or box of label or tag stock media that contains no gap, notch, or mark to separate individual labels or tags.

core diameter The inside diameter measurement of the cardboard core at the center of a ribbon or media roll.

cutter A mechanical device (e.g., rotary or guillotine) used to cut labels or tags following printing.

default The functional setting values returned following a factory reset of the printer.

diagnostics Programs used to locate and diagnose hardware problems.

die-cut media Media that has been cut into a pattern using a press, where the excess paper is removed leaving individual labels, with gaps between them, attached to a backing material.

direct thermal The printing method that uses a heat sensitive media and only the heat of the thermal printhead to create an image on the label.

direct thermal media Media coated with special chemicals that react and darken with the application of heat.

DPI (dots per inch) A measurement of print resolution, rated in the number of thermal elements contained in one inch of the printhead. Also referred to as “resolution”.

DPL programming commands used specifically for control of and label production in the printer. For a complete listing, consult the *Programmer’s Manual*.

fan-fold Media that is folded and stacked.

feed speed The speed at which the media moves under the printhead in non-printed areas and between labels.

Flash memory Non-volatile memory that can be erased and reprogrammed, used to hold the printer’s operating program.

font A set of alphanumeric characters that share a particular typeface.

gap A space between die-cut or notched labels used to sense the top-of-form.

IPS (inches per second) Imperial measurement of printer speeds.

label A paper or synthetic printing material, typically with a pressure sensitive adhesive backing.

label length The distance from the top of the label to the bottom of the label as it exits the printer.

label repeat The distance from the top of one label to the top of the next label.

label tracking Undesirable lateral (side to side) movement of the media as it travels under the printhead.

label width The left to right measurement of the label as it exits the printer.

- media** Generalized term for all types of printing stocks, including: roll fed, continuous, die-cut, and fanfold.
- media hub** Device in the printer used to support roll media.
- media sensor** An electronic device equipped with photosensors to detect media and the top-of-form on die-cut, notched or reflective media.
- MMPS (millimeters per second)** Metric measurement of printer speeds.
- notched stock** Media, typically tag stock, with holes or notches in the material that is used to signal the top-of-form. The printer must be set to 'gap' to use this media type.
- perforation** small cuts extending through the label and backing material to facilitate their separation. Also referred to as "perf".
- print speed** The speed at which the media moves under the printhead during the printing process.
- reflective media** Media that has black marks on the underside of the material used to signal the top-of-form. The printer must be set to 'reflective' to use this media type.
- registration** Repeatable top to bottom alignment of printed labels.
- reverse speed** The backward rate of media motion into the printer during tear-off, peel and present and cutting modes for positioning the label at the start-of-print position.
- ribbon** An extruded polyester tape with several layers of material, one of which is ink-like, used to produce an image on the label. Also referred to as "foil".
- ribbon wrinkle** Undesirable wrinkling of the ribbon leading to voids on the printed label. Typically caused by an improper printhead leveling cam adjustment.
- roll media** A form of media that is wound upon a cardboard core.
- start-of-print** The position on the label where the printing actually begins.

tag stock A heavy paper or synthetic printing material, typically featuring a notch or reflective mark and without an adhesive backing.

thermal transfer The printing method that creates an image by transferring ink from a ribbon onto the media using the heat from the thermal printhead.

TOF (top-of-form) The start of a new label.

void An undesirable blank space in a printed image.

Index

A

Advanced Entry Calibration, 57
alphanumeric, 92, 93, 107, 108
ASCII, 40, 83, 89, 91, 95

B

backing material, 3, 4, 9, 18, 20 - 22,
52, 87, 107, 109
bar code, 46, 63, 76, 85, 91, 94 - 98,
107
black mark, 49, 54, 59, 87
boot loader, 107
burn line, 62, 63, 76

C

cable listing, 13
calibration, 29, 31, 43, 51, 55 - 57, 76,
107
calibration problems, 55, 56
checksum, 95, 97, 107
cleaning schedule, 66
communications, 38, 39, 71, 85. Also
 See Menu Settings
condition messages, 42
configuration, 34, 35
configuration label, 27, 45, 69
continuous media, 107
core diameter, 107
CTS/DTR handshaking, 38
custom adjustments, 32, 36
cutter, 3, 33, 40, 77, 107

D

default, 29, 30, 80, 107
diagnostics, 107
diagnostics. *See* Menu Settings
die-cut media, 50, 107
direct thermal, 4, 9, 10, 16, 17, 63, 88,
108
display, 25, 28, 42, 73
dot test pattern label, 47
download mode, 69
downloading messages, 42

DPI, 86, 108
DPL, 30, 34, 81, 83, 108

E

erratic printing, 73
error messages, 42, 71, 77, 78, 79, 80

F

factory defaults, 36
fails to turn, 75
fan-fold, 108
features, 2, 3
feed speed, 108
flash memory, 3, 69, 70, 71, 107, 108
font, 2, 3, 34, 44, 74, 85, 91, 92, 94,
107, 108

G

gap, 31, 49, 54, 56, 61, 81, 107, 108,
109

H

hex dump mode, 83

I

indicators, 28
inspection, 8
IPS, 10, 86, 102, 108

L

label, 4, 9, 12, 22, 25, 27, 28, 31 - 37,
39, 40, 43, 48, 49, 51 - 55, 58 - 64,
68, 73 - 76, 80, 81, 83, 87, 91,
104, 107 - 110
language, 37
LCD. *See* Display
leveling cam, 62, 74, 76

M

media, *1 - 4, 7 - 11, 14 - 22, 31, 41, 44, 49 - 54, 56, 57 - 69, 75, 76, 78 - 81, 87, 88, 104, 107 - 110*
media rewinder, *18*
media selection, *9*
media sensor adjustment, *49*
media sensor calibration, *51*
media settings. *See* Menu Settings
memory settings, *34*
menu mode, *26, 31, 52, 57*
menu system, *30*
MMPS, *102, 109*
module, *33, 101*

N

notched stock, *51, 109*

P

parallel port, *12, 73*
peel and present, *3, 4, 5, 18, 20*
perforation, *109*
positioning calibration, *51*
present sensor, *33, 40*
print control. *See* Menu Settings
print quality, *9, 44*
print quality label, *44*
print resolutions, *101*
print speed, *10, 109*
printer key, *35*
printer options. *See* Menu Settings
printhead, *14, 16, 17, 22, 49, 50, 62, 63, 65 - 68, 74, 76, 86, 101, 104*
printhead adjustments, *62*

Q

quick test mode, *27, 42, 44*

R

ready mode, *25, 31, 61*
reflective media, *109*
reflective sensor mark. *See* Black Mark

registration, *31, 109*
Resetting, *29*
reverse speed, *109*
ribbon, *4, 9 - 11, 16, 17, 22, 23, 31, 41, 46, 62, 63, 65 - 68, 75, 76, 79, 81, 87, 107, 109, 110*
ribbon sensor, *41, 51, 79*
ribbon test label, *46*
ribbon wrinkling, *62*
roll media, *109*
rotation *4, 76*
RS-422, *38*

S

serial port, *12*
skips, *76*
specifications, *85, 86*
speed Settings, *102*
standard calibration. *See* Media Sensor Calibration
start-of-print, *109*
System Settings. *See* Menu Settings

T

tag stock, *63, 107, 109, 110*
thermal transfer, *9, 10, 16, 17, 22, 63, 88, 104, 110*
TOF, *31, 42, 49, 50, 51, 59, 60, 78, 80, 110*
troubleshooting, *73*

U

unpacking, *7*
user defined label, *48*
user prompts, *42*

V

validation label, *48*
void, *69, 109, 110*

W

warning messages, *42, 77, 81, 82*