

## CR2500 Cable & Handle Installation

The CR2500 is available with USB (6 ft. and 12 ft.), RS232 and PS2 cables. All of the cables are connected to the CR2500 with a 8-pin DIN connector.

### Install a Cable Directly to the CR2500

Line up the 8-pin DIN connector into the back end of the unit. The arrows on the connector should be facing down (Figure 1). When the two items are aligned, firmly push the cable into the reader. The cable has a locking mechanism that will firmly hold the cable in place (Figure 2). To detach the cable, pinch the plastic on the 8-pin DIN and pull back to disengage the connector.



Figure 1



Figure 2

### Reader & H2, BH1/BH2 Handle Assembly

The CR2500 utilizes the battery compartment to 'snap' the reader to the H2, BH1 and BH2 handles. For the H2 (only), push the 8-pin DIN connector at the end of the reader into the flexible connector at the end of the handle. For all three handles, snap the reader onto the handle (Figure 5) matching the battery compartment of the reader to the battery connectors, visible inside the handle (Figure 6). Newer readers (MFG # 012\_05 or later -see Figure 7) can be secured further with threaded screws on the under side of the handle (Figure 8).



Figure 5



Figure 6



Figure 7



Figure 8

### Reader & HI Handle Assembly

Slide the CR2500 into the handle, aligning the 8-pin DIN connector to the stationary connector pin on the handle (Figure 9). Push reader and handle together firmly until you feel the reader 'click' in place.



Figure 9

## Code Reader 2500 - Wireless



### Code Reader 2500 Wireless Setup

This Code Reader 2500 (CR2500) features a Bluetooth® wireless radio. The radio allows for point-to-point wireless communication with other Bluetooth devices that support serial port protocol (SPP). If keyboard entry is necessary, Code XML Router will need to be installed. The following guide will give you general instructions on connecting the CR2500 to a desktop or laptop computer with a Bluetooth radio.

#### Connecting With A QuickConnect Code

The easiest way to connect to a Bluetooth device is to visit the Code website and create a *QuickConnect Code* that is specific to your device (Figure 1). This code will link your CR2500 directly to the desired Bluetooth device. To create a *QuickConnect Code*, you will need to know the Bluetooth address (often referred to as the BD\_ADDR) of that device. You can usually find the 12-character Bluetooth address somewhere on the device near the device's serial number (see Figure 2).



Figure 1



Figure 2



## CR2500 Wireless Setup

If you purchased a CodeXML Bluetooth Modem or a Belkin® Bluetooth adapter from Code or from an authorized distributor, a QuickConnect Code was included. If you bought a Bluetooth adapter separately and wish to create a QuickConnect Code, please visit Code's web site at: <http://www.codecorp.com/bdaddr.php>

### To connect your reader, use the following steps:

1. Power on the CR2500 reader by pressing one of the red buttons for one second to power on the reader.
2. Scan the *Reset to RF Factory Defaults* code on Page 3 (M684\_01).
3. Scan the *QuickConnect Code* you received or created from Code's website.
4. The CR2500 will automatically connect to the computer. By default, the CR2500 will beep once after it connects and beep four times in a row if it did not connect.
5. Scan the *Save Settings* code on Page 3 (M188\_02) if you want to save the wireless connection settings to the CR2500 so that the CR2500 will automatically try to connect wirelessly the next time it is powered on.

**Important Note:** You will need to locate the Communications (COM) Port assigned to the Bluetooth serial port protocol. While installing the Bluetooth Configuration Manager software that was included with your Bluetooth adapter, make sure to note the Communications (COM) Port number the software assigned for the adapter (e.g., COM 10). This is the COM Port through which the CR2500 will connect.

## Reading Tips



Too far from code.



Too close to code.



Optimal distance from code is 3.3" (85mm).

CR2500's unique targeting function uses two converging targeting LEDs to guide the user to optimal reading range.

### Reset to RF Factory Defaults



M684\_01

### QuickConnect



00BEB021A035

Scan the QuickConnect code that matches the Bluetooth address of your device.

### Save Settings



M188\_02

### Radio Range and Transferring Data

The CR2500 radio is a Class 1 device. If connected to another Class 1 device the unit has roughly a 300 feet line-of-sight operating range. If connecting to a Class 2 or Class 3 device, the operating range will drop to match the lower range. Once a unit is connected, a serial application must be opened (HyperTerminal) unless CodeXML Router is installed.

When the CR2500 detects the radio is out of range, the CR2500 will store data on the reader's non-volatile memory.

For more information about setting up and using the CR2500 with a wireless Bluetooth configuration, please visit [www.codecorp.com/manuals.html](http://www.codecorp.com/manuals.html) and download the latest version of the CR2500 User Manual.

### CR2500 Accessories:

- Handles
- Battery Handles
- Lanyard Hook Attachment
- Battery Chargers (single/two bay)
- Reader Stand

Visit [www.codecorp.com](http://www.codecorp.com) for information on all Code readers and accessories.

## Handle Kit Instructions

FOR REFERENCE  
USE ONLY

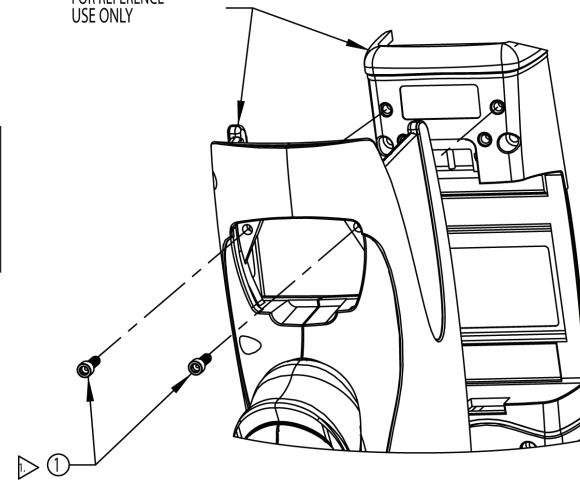

1. Route item 1 (x2) as shown mate with corresponding inserts in CR2500 reader
2. Slowly thread both screws half-way down
3. Continue to tighten screws in small increments, alternating between the right and left screw until fully seated
4. Screws shall be tightened to a torque setting of 2 inch-lbs