

# IRX200

**USER GUIDE**

**OPERATING IN NORMAL MODE**

## 1 TABLE OF CONTENTS

1.	INTRODUCTION.....	4
1.1.	SECURITY RECOMMENDATIONS .....	4
1.2.	REFERENCE DOCUMENTS .....	4
1.3.	PACKAGE CONTENT.....	4
1.4.	VARIANTS.....	5
1.5.	ACCESSORIES .....	5
2.	TECHNICAL DATA.....	6
2.1.	ELECTRICAL AND MECHANICAL SPECIFICATIONS .....	6
2.2.	ANTENNA SPECIFICATIONS.....	8
2.2.1.	INTERNAL ANTENNA .....	8
2.2.2.	BRADY XA20 .....	8
2.3.	THERMAL MANAGEMENT .....	10
3.	SETTING UP THE DEVICE.....	11
3.1.	MOUNTING .....	11
3.2.	CONNECTING THE DEVICE .....	12
3.2.1.	CONNECTORS.....	12
3.2.2.	FACTORY RESET WITH CABLE.....	13
3.3.	LED INDICATORS .....	15
3.4.	ACCESSING THE DEVICE ADMIN WEB UI.....	17
3.4.1.	DISCOVERING THE DEVICE USING BRADY SMART DEVICE CONTROL APP....	17
3.4.1.	USING USB CONNECTION.....	17
3.4.2.	USING ETHERNET CONNECTION (NORMAL/OPC UA MODES).....	18
3.4.3.	OBTAINING PASSWORD AND USERNAME.....	18
3.5.	SELECTING THE OPERATING MODE.....	19
3.6.	CONFIGURING THE NETWORK SETTINGS in normal/opc ua MODE .....	19
3.7.	TESTING THE RFID READING.....	20
3.7.1.	BRADY RFID DEMO APP.....	20
3.7.2.	EMBEDDED RFID SAMPLE APP.....	20
3.7.3.	ADJUSTING RFID SETTINGS.....	21
4.	WEB MANAGEMENT INTERFACE.....	21
4.1.	MAIN MENU.....	21
4.2.	DASHBOARD.....	22
4.3.	SYSTEM .....	23

4.4.	NETWORK.....	28
4.5.	HARDWARE .....	31
4.6.	RFID.....	32
4.7.	SOFTWARE.....	35
4.7.1.	PLUGINS and APPLICATIONS CREDENTIALS.....	36
4.8.	INDUSTRIAL.....	40
5.	DEVICE API'S AND CUSTOM SOFTWARE DEVELOPMENT.....	41
5.1.	SYSTEM RPC API.....	41
5.2.	NUR API .....	41
5.3.	APPLICATION PACKAGING AND SIGNING.....	41
6.	COMPLIANCE STATEMENTS.....	42
6.1.	REGIONAL SETTINGS .....	42
6.2.	CE.....	42
6.3.	FCC/IC.....	42
6.4.	RF EXPOSURE.....	43
7.	SERVICE AND SUPPORT.....	43
8.	WARRANTY.....	44
9.	VERSION HISTORY.....	44

## 1. INTRODUCTION

This manual contains information about the installation, functions and operating of the Brady IRX200.

The Brady IRX200 is a powerful UHF RFID industrial reader designed for challenging environments. The active face is made of PC-ABS V0, halogen-free flame-retardant filament and the housing is class ADC12 aluminum with powder coating with Surtec650 corrosion protection. The reader has ingress protection code IP67.

As a conventional RFID reader, the embedded computer with Linux OS enables installation and operation of personal and 3rd party applications and makes the system much more scalable and manageable than most readers.

The dedicated 64bit A53 cores running Linux OS, and in addition, quad R5F cores running real-time tasks make the reader a high-performance industrial reader.

The integrated OPC UA AutoID server support makes it easy to connect the reader into existing industrial systems.

### 1.1. SECURITY RECOMMENDATIONS

- The device should only be used in accordance with applicable laws and regulations.
- The default password should be changed after the first login. The password should be kept secure.
- Always use the latest firmware.
- Use firewall configured with restrictive rules.

### 1.2. REFERENCE DOCUMENTS

Besides this document, the following material can be found from [www.brady.eu/all-downloads#4293928306](http://www.brady.eu/all-downloads#4293928306).

- Brady datasheet
- Brady Safety and Regulations Guide
- Nordic ID GitHub account for developers (<https://github.com/NordicID>)

### 1.3. PACKAGE CONTENT

Brady IRX200 package contains the following items:

- Brady IRX200 reader
- Safety and regulations card

NOTE! Power supply not included.

NOTE! The product label on the underside of the reader contains the default password and the serial number. Make note of them.

## 1.4. VARIANTS

The IRX200 is available as the ETSI and FCC/IC variants.

CODE	DESCRIPTION
321713	Brady IRX200 ETSI 865.6-867.6 MHz
321714	Brady IRX200 FCC/IC 902-928 MHz

## 1.5. ACCESSORIES

The IRX200 accessories include power supplies with different plug types and cables.

CODE	DESCRIPTION
321907	Power supply for IRX200, with power cord EU
321908	Power supply for IRX200, 30W with power cord UK
321909	Power supply for IRX200, 30W with power cord US
321910	Power supply for IRX200, 30W with power cord AU
321911	Power supply for IRX200, 30W with power cord CN
321914	Power cable for IRX200, stripped cables, 2m
321912	USB debug cable for IRX200 (M12 A-coded (8 pin) to USB + stripped IO cables)
321913	IO cable for IRX200 (M12 A-coded (8 pin) to Stripped IO cables)
321900	Ethernet cable for IRX200 (length 5m, M12 X-coded to RJ45)
321901	Ethernet cable for IRX200 (length 10m, M12 X-coded to RJ45)
321902	Ethernet cable for IRX200 (length 20m, M12 X-coded to RJ45)
321903	Antenna cable R-TNC for IRX200 (length 1m, RP-TNC to RP-TNC)
321904	Antenna cable R-TNC for IRX200 (length 3m, RP-TNC to RP-TNC)
321905	Antenna cable R-TNC for IRX200 (length 5m, RP-TNC to RP-TNC)
321906	Antenna cable R-TNC for IRX200 (length 10m, RP-TNC to RP-TNC)

## 2. TECHNICAL DATA

This section provides technical information about the IRX200:

### 2.1. ELECTRICAL AND MECHANICAL SPECIFICATIONS

UHF RFID DATA	
Supported standard	ISO 18000-63 (EPC Class 1 Gen2v2)
Frequency	ETSI 865.6–867.6 MHz or FCC/IC 902–928 MHz
Integrated antenna features	Circular polarization with very low axial ratio
Maximum radiated RF power	33dBm (2W) ERP / 3.3W EIRP
Max receiver sensitivity	-87 dBm
Reading speed	Over 1000 tags/s
External antenna port	1 RP-TNC female with maximum conducted power 30dBm
PLATFORM	
CPU	Dual-core 64bit A53 with quad-core R5F co-CPU's
Operating system	Hardened Linux
Memory	2GB RAM, 8GB Flash
USER INTERFACE	
Indicators	6pcs status LEDs, 2pcs high visibility LED bars
LAN	Ethernet 10/100/1000Mbit, Connector: M12 X-coded
USB	USB composite device (CDC/HID/RNDIS/ECM), Connector: M12 A-coded 8pin
IO	1 input and 1 output, 24V output for powering sensors
POWER	
Operating power	12W with maximum RF transmission power on, 4W in idle state, RF not transmitting
External power supply	AC adapter: input 100–240 VAC, 1 A, 50-60 Hz / output 24 VDC, 1.25A, 30W / Power adapter for EU, UK or US Connector: M12 L-coded (FE connected)
SIZE AND WEIGHT	
Dimensions	H 200 mm W 200 mm L 28 mm
Weight	1.1 kg / 38.8 oz
SOFTWARE INTERFACE	
Management interface	Via Web management UI and SSH for developers
Firmware update	Via Web management UI and the RESTful service
IP addressing	IPv4 DHCP (DCP in PNIO mode) or static IP
API support	NUR API for RFID and RESTful service to access reader configurations, IRP API for PNIO
Security	TSL v1.3
Industrial protocols	OPC UA AutoID server support Profinet IO device CC-B with 1ms cycle time
Software development	Application can be written with modern programming languages. Internal RPC library for C++/Rust/Python/C#

ENVIRONMENT	
Temperature	Operating Storage -20 to +55 °C -4 to +131°F -20 to +60 °C -4 to +140 °F
Relative humidity	10 % to 95 % non-condensing
Mounting	VESA 100 compatible
Environmental sealing	IP67
Shock and vibration	EN60068-2-27 / EN60068-2-6(4)
ESD	Contacts Air discharge +/- 4kVdc +/- 8kVdc

## 2.2. ANTENNA SPECIFICATIONS

The IRX200 has an internal circularly polarized high gain antenna. If read coverage needs to be extended, Brady offers the XA20 industrial antenna that can be connected to the reader by using the RP-TNC to RP-TNC coaxial cable.

### 2.2.1. INTERNAL ANTENNA

Reading distance can be controlled via software by the configured transmission power level.

Antenna parameters:

UHF RFID	VALUE
Frequency	ETSI 865.6–867.6 MHz and FCC/IC 902–928 MHz
Gain	7.5 dBic
Beam width (-3dB)	70°
Front-to-back ratio	12dB
Axial ratio	<1dB
VSWR	< 1.5:1
Maximum input power	2W

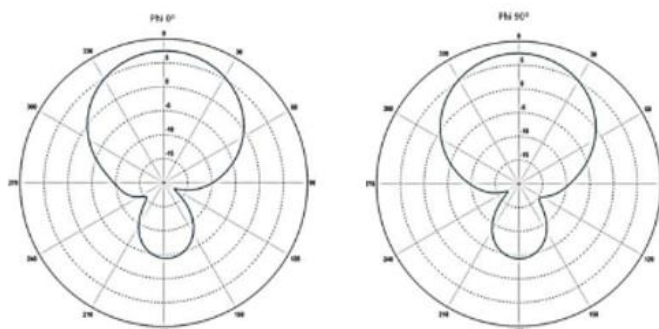

Figure 1: Radiation pattern of the internal antenna

### 2.2.2. BRADY XA20

The Brady X20 is available as:

CODE	DESCRIPTION
321897	Brady XA20 Industrial Antenna EU
321898	Brady XA20 Industrial Antenna US





Figure 2: Brady XA20 Industrial Antenna

UHF RFID	VALUE
Frequency	ETSI 865.6–867.6 MHz and FCC/IC 902–928 MHz
Gain	7.5 dBic
Beam width (-3dB)	70°
Front-to-back ratio	12dB
Axial ratio	<1dB
VSWR	< 1.5:1
Maximum input power	2W
RF CONNECTOR	RP-TNC

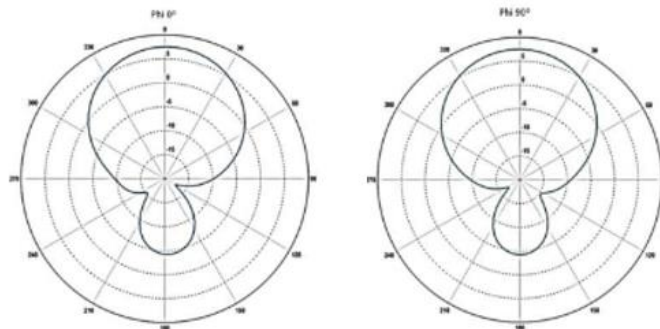

Figure 3: Radiation pattern of the Brady XA20

**NOTE!** The reading range depends on the tag(s) used and the environment.

## 2.3. THERMAL MANAGEMENT

Brady IRX200 reader includes sophisticated thermal management features that prevent overheating issues if the reader is used in too warm environments. The reader monitors temperatures of the onboard computer and the UHF RFID module and adjusts operation points based on the temperature information.

Onboard computer starts a mitigation scheme (for example clock frequencies of CPUs are dropped) when temperature of the onboard computer reaches 85°C.

Thermal mitigation scheme of the UHF RFID module starts when it reaches 80°C. From that moment on, UHF RFID reading operations are suspended for 100ms and suspend time is increased 20ms by every °C the temperature rises. The thermal mitigation scheme is turned off once the temperature drops below 80°C. High temperature warning message (TEMP\_HIGH) is sent via NUR API to host. The warning message contains also current temperature information.

### 3. SETTING UP THE DEVICE

This section guides through the installation of the device.

#### 3.1. MOUNTING

Mounting accessories are not a part of the package content.

The device is mounted using the VESA 100 × 100 standard; four horizontally and vertically threaded M5 holes spaced 100mm apart. The maximum length of fastening screws is 8mm plus the thickness of the VESA bracket. The device can be mounted in any position.

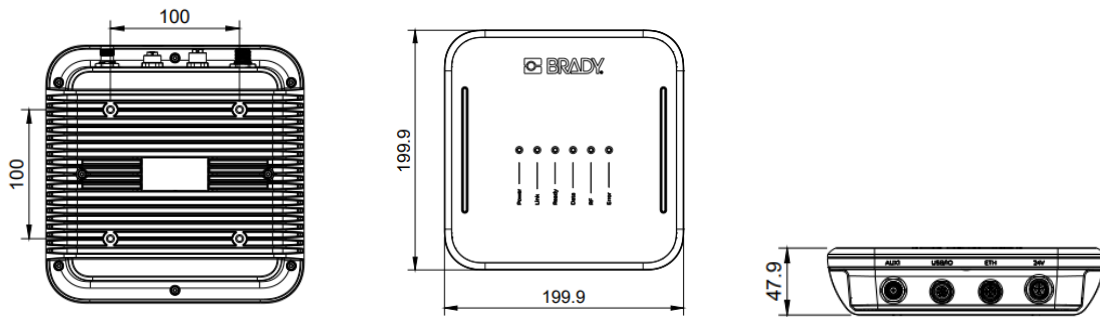

Figure 4: Rear, front and side view and the dimensions of the IRX200 reader

## 3.2. CONNECTING THE DEVICE

The IRX200 has four connectors:



Figure 5: Connectors of the BRADY IRX200

### 3.2.1. CONNECTORS

#### RP-TNC - EXTERNAL RFID ANTENNA PORT, MALE

The IRX200 includes an RP-TNC connector for connecting an external RFID antenna to the device. The impedance of the antenna port is 50Ω and maximum conducted output power is 33dBm.

The external antenna port can be enabled via the software API or the admin Web UI in normal mode.

#### M12-A 8PIN – USB/IO PORT, FEMALE

The reader has an M12-A connector which combines multiple functions. USB composite device (Profiles: CDC-ECM/RNDIS), GPIO 1 input and 1 output, 24V output for powering sensors and factory reset.

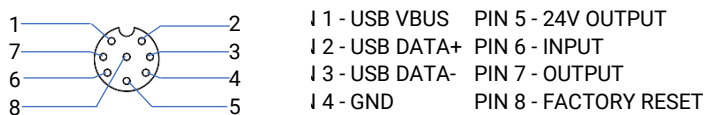

Figure 6: Front view of connector



Figure 7: Cable view

	VOLTAGE MIN (V)	VOLTAGE NOMINAL (V)	VOLTAGE MAX (V)	Condition
Input, high	11	24	60	min 2,6mA
Input, low	0	0	8	
Output, high			30	
Output, low		0	0,6	max 25mA
24V output		24		<250mA
GND		0		

Figure 8: Electrical specifications table of the IO connector

	VOLTAGE MIN (V)	VOLTAGE NOMINAL (V)	VOLTAGE MAX (V)	Condition
Input, high	11	24	60	min 2,6mA
Input, low	0	0	8	
Output, high (Open collector)			30	
Output, low		0	0,6	max 25mA
24V output		24		<250mA
GND		0		

Figure 9: Electrical specifications table of the IO connector

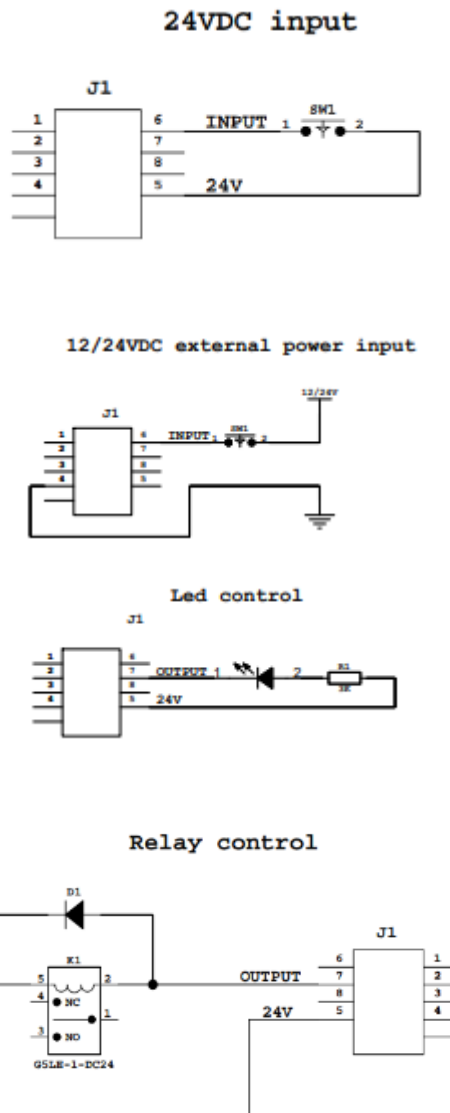

Figure 10, Connection examples

### 3.2.2. FACTORY RESET WITH CABLE

The reader can be reset with the USB debug cable as follows:

- Keep the black and brown stripped IO wires connected while powering up the reader
- During boot, Power and Error LEDs will light up, then Link and RF and finally Ready and Data.
- Wait until Ready and Data LEDs light up. Then release the stripped cables. If released after more than 3 seconds, the reader does a regular boot.

### M12-X ETHERNET CONNECTOR, FEMALE

The Brady IRX200 includes an Ethernet connector. The reader supports 10/100/1000Mbps speed classes.

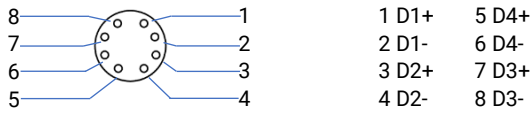

Figure 11: Front view of connector



Figure 12: Cable view

### M12 L 4P+PE, 24V POWER IN PORT, MALE

The IRX200 DC connector for powering the unit.

The reader powers up automatically when connected to a power supply.

Connect the power supply to the device per the following pin assignment.

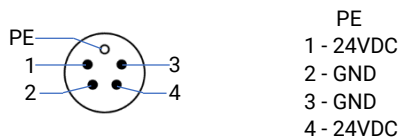

Figure 13: Front view



Figure 14: Cable view

**NOTE!** The recommended tightening torque for all connectors is 8Nm.

### 3.3. LED INDICATORS

The user interface of the Brady IRX200 consists of six LED indicators:

- Power LED
- Link LED
- Ready LED
- Data LED
- RF LED
- Error LED
- 2 LED bars

LED	Mode	State	Indication
Power	ALL MODES	Off	Device is not on.
	ALL MODES	Green, static	The device is powered on.
	ALL MODES	Orange, static	The device is upgrading.
Link	ALL MODES	Off	Off: All the communication interfaces are disabled.
	ALL MODES	Green, static	Ethernet/PROFINET link is up.
	ALL MODES	Orange, blinking	Blinking according to received or transferred data.
Ready	ALL MODES	Off	No set IP or the ethernet cable is not attached. Device is not on.
	NORMAL/ OPC UA	Green, slow blinking	IP set.
	NORMAL/ OPC UA	Green, static	RFID service running while having an IP.
	PROFINET	Green, static	Active PROFINET connection.
	PROFINET	Green, fast blinking	Link is up, IP defined, not connected in PROFINET.
Data	ALL MODES	Off	Device is not on.
	NORMAL/ OPC UA		The data LED can be controlled by the device's system APIs. Indicates that the device has data for the PLC.
	PROFINET	Green, static	Device has outgoing data waiting to be read.
	PROFINET	Red, static	Device outgoing buffer is full, PLC has not read incoming.
RF	ALL MODES	Off	The RFID module is not transmitting.
	ALL MODES	Green, static	The RFID module (NUR service) is transmitting.
	ALL MODES	Yellow, static	High reflections at receiver.
	ALL MODES	Blue, static	Access/write/read error.
	ALL MODES	Red, static	RFID hardware error.
Error	ALL MODES	Red, blinking	Critical internal error.
LED bars			The LED bars can be controlled by the device's system APIs.



Figure 15: The placement of individual LEDs and the LED bars of the Brady IRX200



### 3.4. ACCESSING THE DEVICE ADMIN WEB UI

Brady IRX200 admin web user interface can be accessed in two different ways: through the Ethernet and the USB connection.

#### 3.4.1. DISCOVERING THE DEVICE USING BRADY SMART DEVICE CONTROL APP

Brady Smart Device control is an application for detecting Brady RFID readers in local or PAN networks and accessing their web user interface. It is available at:

[https://www.brady.eu/downloads?filename=Brady\\_Smart\\_Device\\_Control\\_v105.zip](https://www.brady.eu/downloads?filename=Brady_Smart_Device_Control_v105.zip).

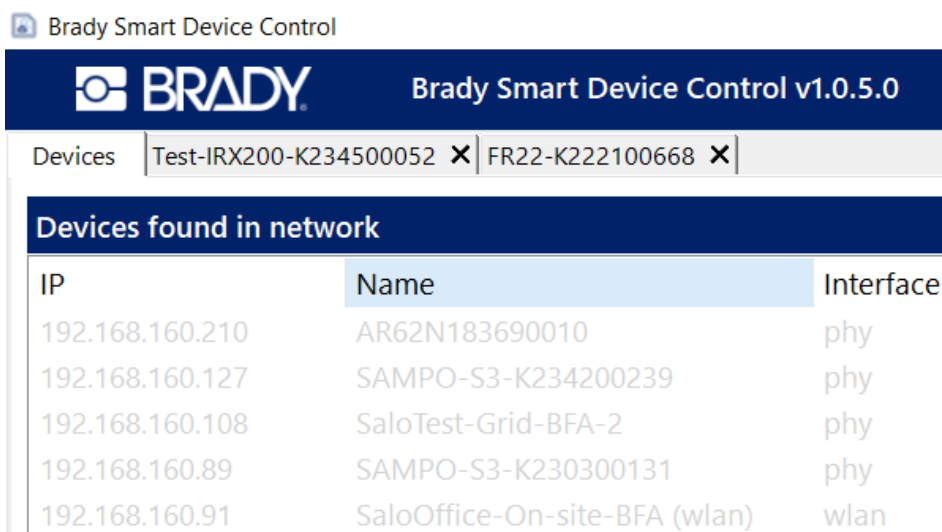

Figure 16: Brady Admin Device Control

#### 3.4.1. USING USB CONNECTION

The device supports USB RNDIS and CDC-ECM profiles which allow to access the device's admin Web UI through TCP/IP connections.

When the USB cable is connected, the IP address of the device is 169.254.0.1 by default. Typing the IP to the web browser will open the login screen of the Web UI.

**NOTE!** USB cable is not included in the package.

### 3.4.2. USING ETHERNET CONNECTION (NORMAL/OPC UA MODES)

By default, the network interface is set to DHCP mode, and the MAC address of the interface is indicated on the product label on the underside of the device. To access the Web UI, you need to connect the IRX200 and the PC into the same local network having a DHCP server.

- The connection can be established typing the IRX200's hostname in the address bar of a web browser if the network and host device support mDNS. The default hostname for IRX200 is:

*irx200-serialnumber*

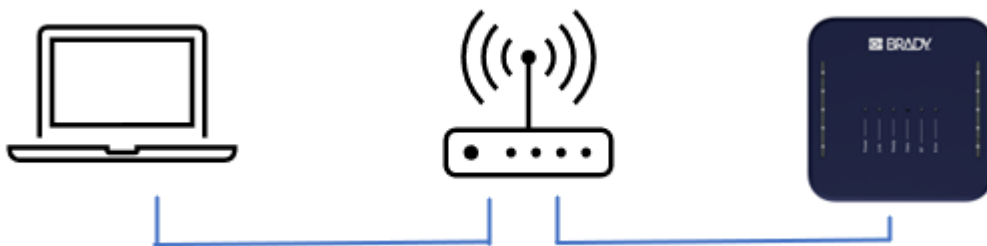

Figure 17. Connecting the IRX200 to PC via router with integrated DHCP server.

When the IP address of the Brady IRX200 is known, typing it in the address bar of a web browser will open the login screen of the Web UI. Applications like the Brady Smart Device Control can be used to discover the address.

### 3.4.3. OBTAINING PASSWORD AND USERNAME

The default username (“admin”) and password are printed on the product label attached to the under side of the device.

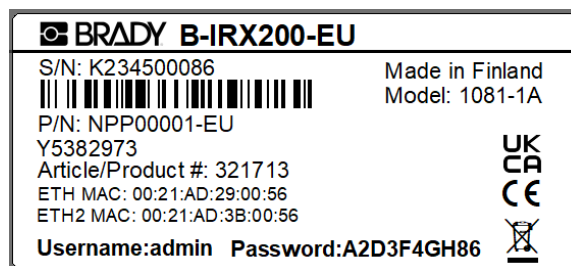

Figure 18: Type label on the back side of the Brady IRX200

Note that a security alert will pop up on the browser the first time that you connect to the device, as the connection is forced to be secure. This alert will disappear as soon as you install a certificate on your device (see section 4.4).

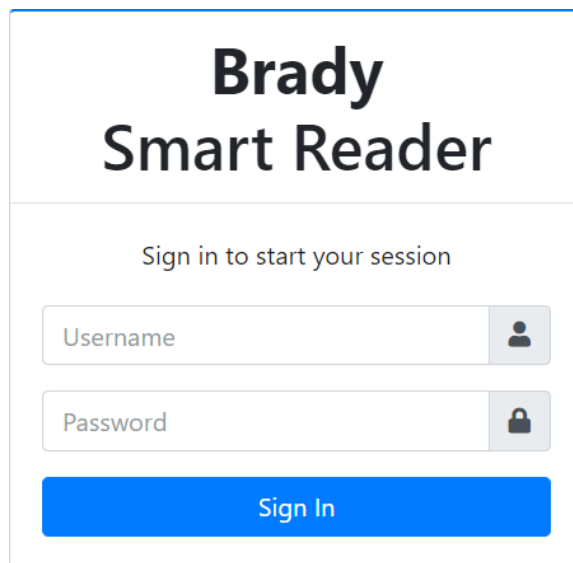

Figure 19: Web UI log in form

### 3.5. SELECTING THE OPERATING MODE

The Brady IRX200 reader has two operating modes: normal mode and PROFINET mode. In normal mode, the device’s ethernet port is controlled by the Linux OS, and PROFINET functionalities are disabled. In normal mode, the legacy UHF RFID interface called NurApi can be used to control the UHF RFID engine.

In PROFINET mode, the legacy NurApi interface is not available and control of the ethernet port is handed over to the real-time OS running the PROFINET functionality.

The operating mode can be changed from the device’s Web UI (see section 4.8). Note that reboot of the device is needed before the new selection becomes active. While operating mode is PROFINET, a PROFINET specific sub-page “Industrial” appears in the Menu.

To read more about operating the IRX200 in PROFINET mode, see the guide BRADY IRX200, Getting started with PROFINET available at [www.brady.eu/all-downloads#4293928306](http://www.brady.eu/all-downloads#4293928306).

### 3.6. CONFIGURING THE NETWORK SETTINGS IN NORMAL/OPC UA MODE

To change network settings go to the Network tab of the web user interface (see section 4.4). IP configuration is under the subsection Network.

### 3.7. TESTING THE RFID READING

To confirm a successful installation, RFID reading should be tested.

Brady provides the following Windows tools to test and configure the reader in normal mode:

#### 3.7.1. BRADY RFID DEMO APP

The Brady RFID Demo application is used to perform RFID reading and writing tests. The application provides statistics on the reading performance and logging capabilities for a more thorough evaluation. It is available for Microsoft Windows and Android OS.

The application also allows adjusting the RFID parameters on the fly for better understanding their impact on the reading performance. Note that altered settings cannot be stored permanently into the device. The settings are reverted to defaults upon a power cycle.

The Brady RFID Demo App for Windows can be downloaded from:

<https://www.nordicid.com/support/devices-downloads/nordic-id-fr22/>

#### 3.7.2. EMBEDDED RFID SAMPLE APP

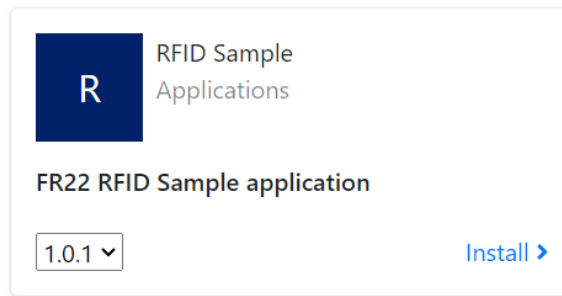

Figure 20. The RFID sample application in the App Center

The embedded RFID sample app can be installed from the App Center, a repository of apps and plugins. App Center can be found from Web UI tab Software. See section 4.7.

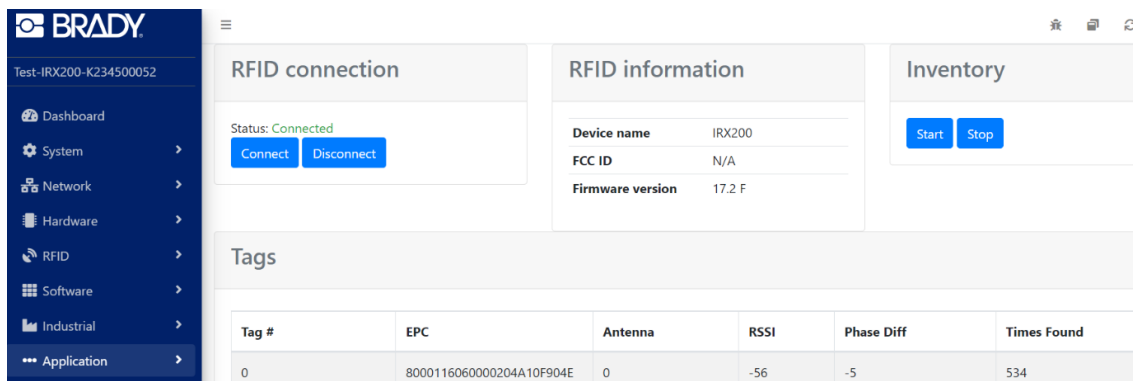

Figure 21. The RFID sample app

### 3.7.3. ADJUSTING RFID SETTINGS

Place several tags within the location covered by the reader you are testing. Check for coverage in the location.

Adjust RFID settings such as TX Level and RSSi value from the Web UI tab RFID (see section 4.6).

## 4. WEB MANAGEMENT INTERFACE

The web user interface has a responsive design, which makes it fully functional in web browsers from computers, tablets, to smartphones.

The IRX200 management interface is used for:

- System health monitor
- System logs
- Factory reset
- Configuring public web user interface (application, admin, web page etc.)
- Access management
- Network configuration
- Firewall configuration
- Hardware settings
- RFID configuration
- Firmware update
- Applications and plugins management.
- Industrial protocol settings

### 4.1. MAIN MENU

Brady IRX200 displays a side navigation menu to access all the different available options to manage the device. The menu panel can also be hidden.

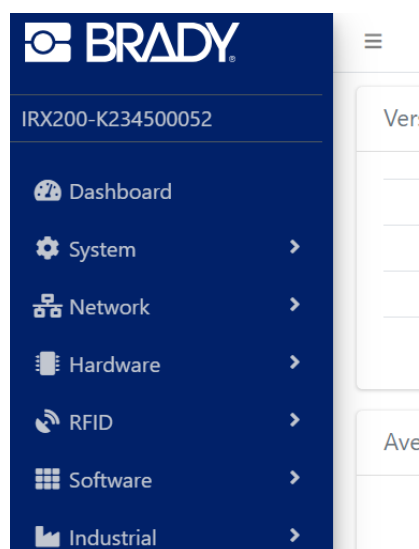

Figure 22: Main menu view

There are also four icons always accessible on the top right corner of the screen, to:

- Download debug logs
- Open current frame in new window
- Reboot the device
- Toggle full screen mode
- Logout



## 4.2. DASHBOARD

The default landing page is the dashboard, where you can see the system status and health monitor in real time.

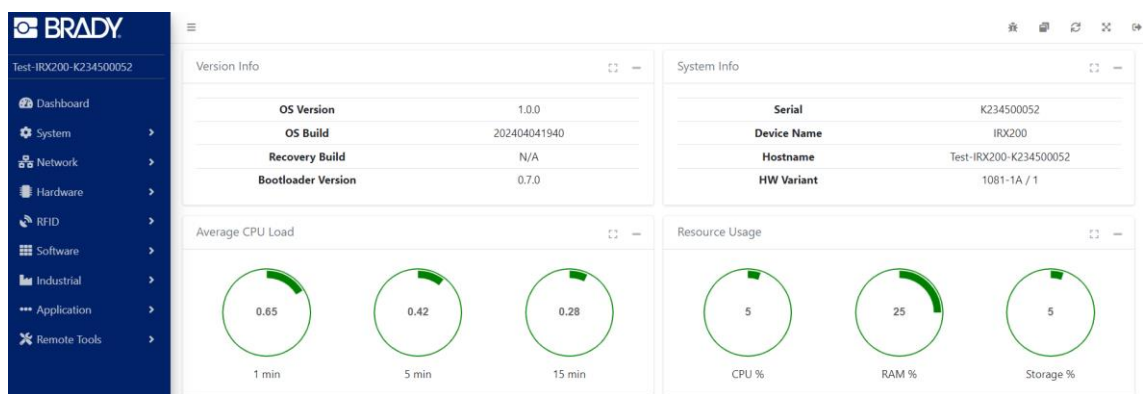

Figure 23: Dashboard view

Visually, green metrics indicate that the device is behaving as expected. Red metrics would require immediate action on the physical device, environment, or software applications to solve the issues.

This page is shown every time you connect to the device Web UI, but you can configure any other page or application to be shown by default instead of the dashboard, as explained in section 4.3.

### 4.3. SYSTEM

The system menu has six sections, most of them meant for developers.

#### API DOCS

Describes the functions of the system API to control the reader.

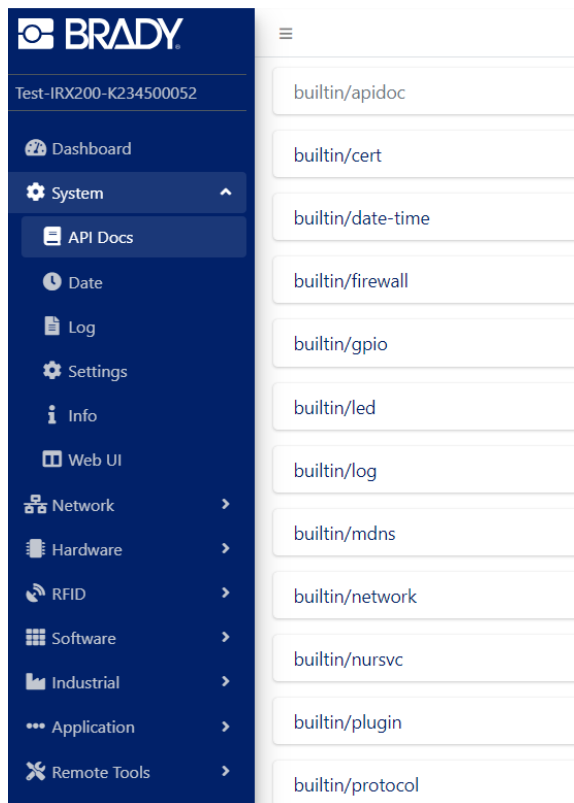

Figure 24: API Docs view

- API endpoints Click the endpoints open to see the base endpoints, their description, possible payload, and responses.

## DATE

System time management. Date and time can be adjusted manually or automatically using NTP servers.

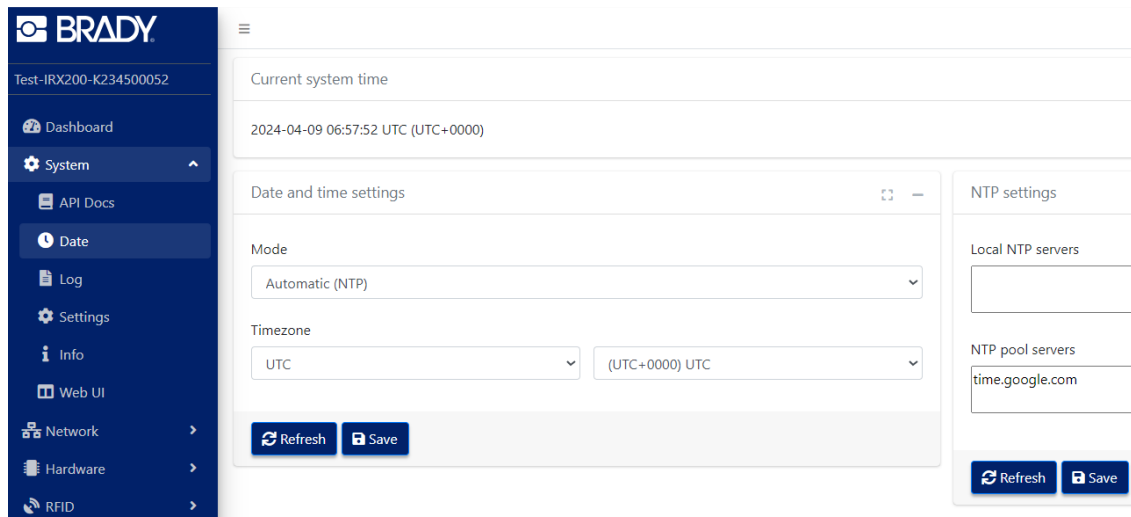

Figure 25: Date view

- Current system time                      Shows the current time
- Mode    Automatic (NTP) or manual.
- Timezone                                        Must be set manually
- Local NTP servers                            Local NTP server address here
- NTP pool servers                             NTP pool server address here



## LOG

Shows the logged events and allows to filter them. Download button for debugging purposes.

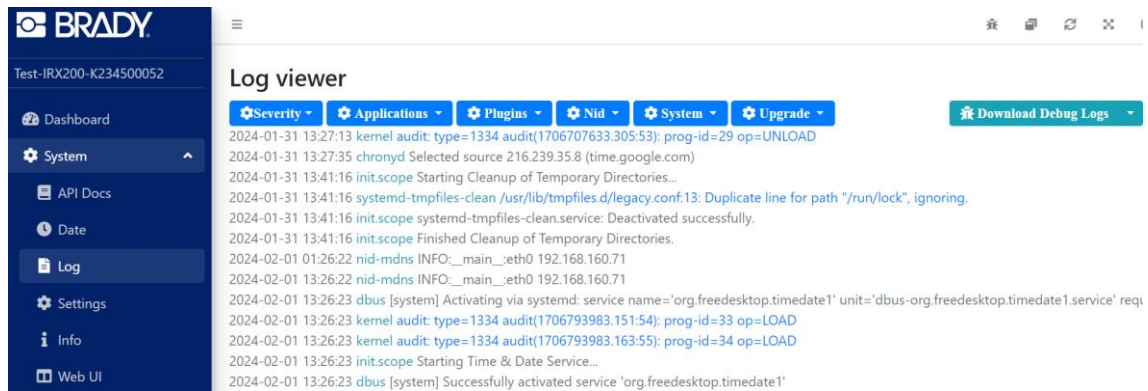

Figure 26: Log view

- Severity Filter log events by severity level
- Applications Filter log to show only application's events
- Plugins Filter log to show only plugin's events
- Nid Filter log to show vendor service logs
- System Filter log to show service logs
- Download Debug Logs By default, logs are written to RAM. Record logs to flash by switching toggle from drop down. Drop down shows number of stored logs

## SETTINGS

Import configuration settings to reader or export configuration settings to a file.

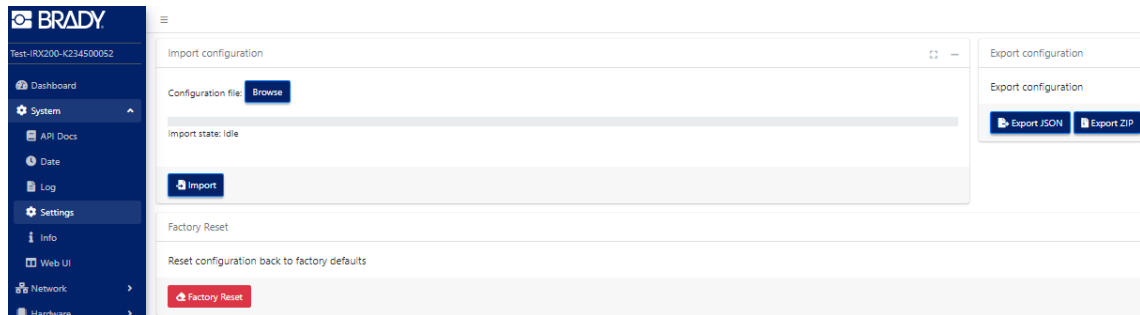

Figure 27: Settings view

- **Import** Import configuration file to apply settings for normal mode.
- **Export** Export configuration settings as a JSON file or a ZIP file.
- **Factory reset** Restores the original settings and erases all installed applications and plugins.

**NOTE!** Profinet firmware settings are not included in the configuration file.

## INFO

Contains more detailed information about the data shown on the dashboard page: hardware versions, software versions and performance metrics. Also shows persistent hardware parameters, such as device variant, serial number or MAC addresses.

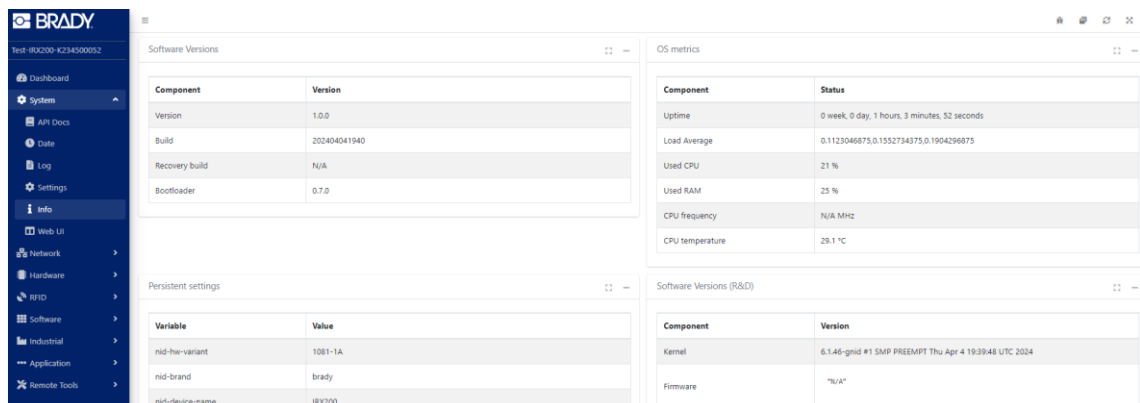

Figure 28: Info view

## WEB UI

Managing the access to the web user interface.

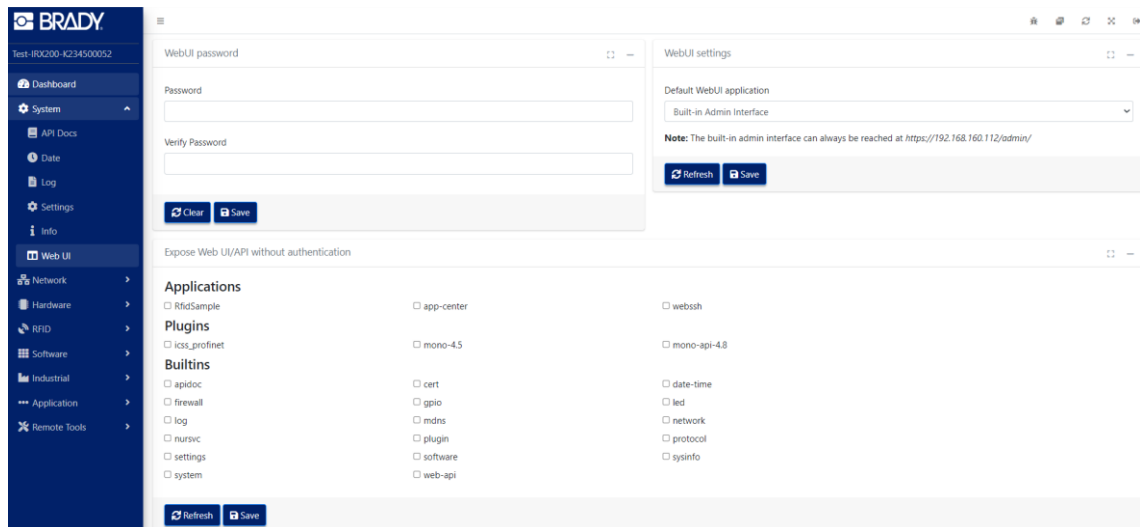

Figure 29: Web UI view

- **WebUI password** Change password. Administrator username is always "admin".
- **Default WebUI application** Choose the default landing page for normal mode from drop down. Landing page can be any installed application, plugin page or settings page. The built-in administrator interface can always be reached at [https://\[device\\_IP\]/admin/](https://[device_IP]/admin/)
- **Expose Web UI/API without authentication** Choose Applications or Builtins views to access without login authentication.

**NOTE!** Be careful when exposing administrator pages without authentication to avoid unwanted changes on your device!

## 4.4. NETWORK

### CERTIFICATES

Install your own web server certificates to avoid security warnings and increase the security of the network.



Figure 30: Security warning on the web navigation bar

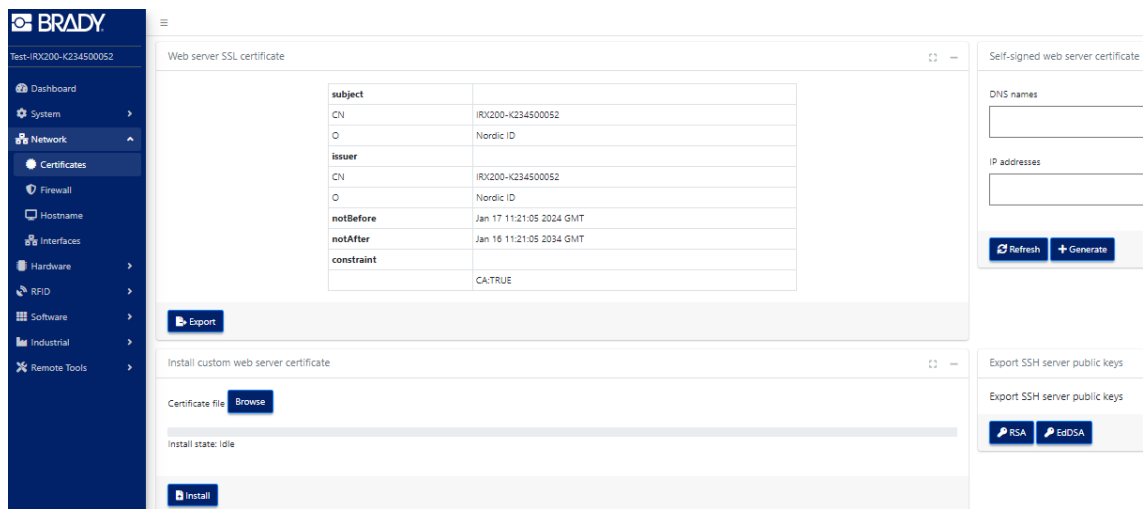

Figure 31: certification view

- Web server SSL certificate      IRX200's SSL certificate information
- Self-signed web server certificate      Add DNS names and IP addresses
- Install custom web server certificate      Browse and install certificate from file
- Export SSH server public keys      Make public keys available

## FIREWALL

Regulate or block the traffic that passes to and from the system following set iptables rules.

Note that iptables rules are transitory, they need to be saved for them to persist after reboot.



Figure 32: Firewall view

- Firewall settings

Control access to Web UI and SSH access, and manage support's VPN access from dropdowns. Regulate or block incoming or outgoing network traffic. For example, if the user wants to block connections from a specific IP address "198.168.156.24", they add into input rules the following command: `-s 198.168.156.24 -j DROP`

## HOSTNAME

Change hostname for the IRX200 device.

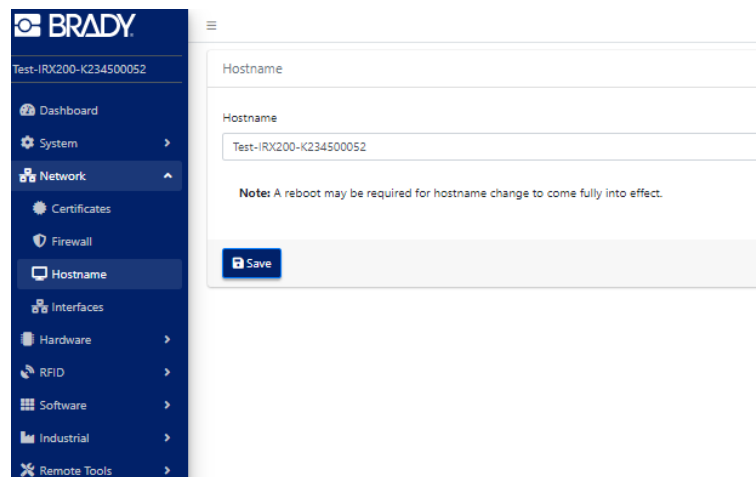

Figure 33: Hostname view

- Hostname Type the hostname the reader can be reached with along with it's IP address.

## INTERFACES

Network interfaces and IP configuration.

In normal mode, the USB is enabled, making the device accessible via USB.

When in industrial mode the ethernet interface is disabled.

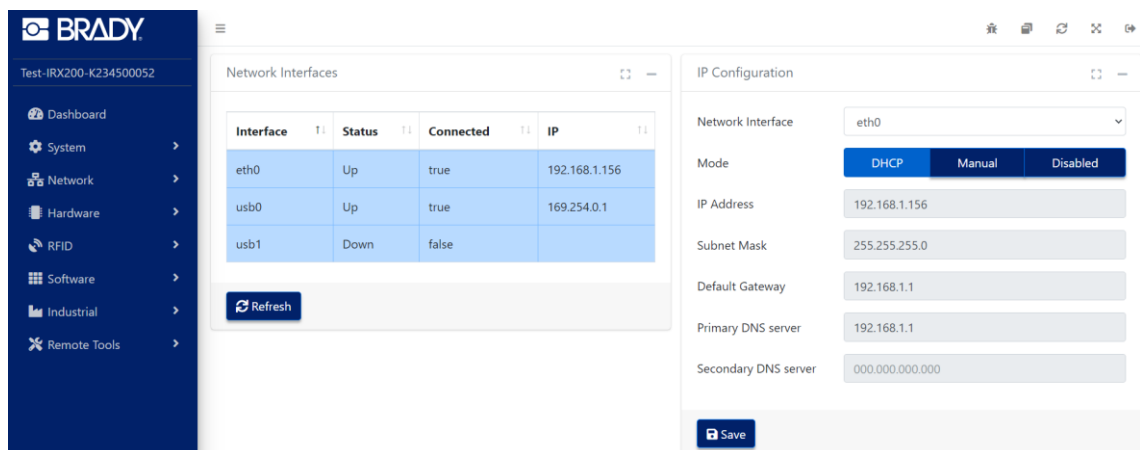

Figure 34: Interfaces tab from Network settings in normal mode

- Network interfaces Available interfaces, their status, connection status and IP.
- IP configuration Configure network interfaces. Choose interface from dropdown. Change interface parameters.







## SETTINGS

RFID settings of the reader in normal mode.

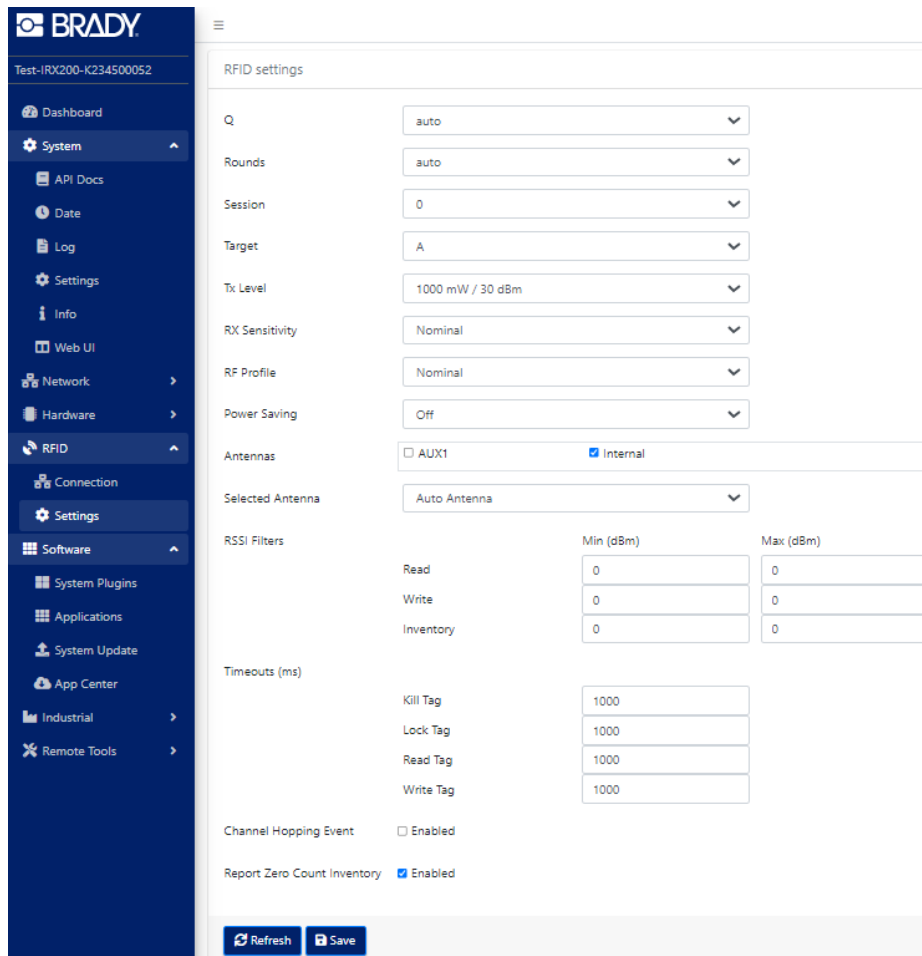

Figure 37: Settings view

- **Q** The parameter reader uses to regulate the probability of tag response during inventory. The number of slots is  $2^Q$ .
- **Rounds** Defines the number of query rounds done inside one inventory round.
- **Session** There are four available sessions to determine when a tag will respond to a reader, or that allow tags to maintain their independent state.
- **Target** Target selects whether Tags whose inventoried flag is A or B participate in the inventory round. Tags may change their inventoried flag from A to B (or vice versa) because of being singulated.
- **Tx Level** The transmit power level.
- **RX Sensitivity** No impact/legacy setting.

- **RF Profile**

Three different profiles that define how the reader interacts with tags:  
Nominal is the default setting. It has link frequency of 320 kHz and Miller 4 in ETSI lower band regions and link frequency of 250 kHz with Miller 4 coding in FCC regions and sub-sets of that. This profile uses tight DRM filters and is suitable for environments having a lot of interferences. Nominal profile provides read rates up to 250 tags/s.  
Robust is intended to be used to obtain maximum reader sensitivity. This profile uses link frequency of 160 kHz and Miller 8 coding scheme providing read rates up to 80 tags/s. Due to the best sensitivity, this profile can be used when maximum read range is needed.  
High speed is intended to be used when highest read rates are required. It uses link frequency of 640 kHz and FM0 coding and provides read rates up to 1000 tags/s. Due to the high data speed this profile is quite sensitive to interferences. Also, maximum sensitivity is decreased compared to robust and nominal profiles.
- **Power Saving**

For applying dynamic duty cycle while continuous reading is on and no tags in the reader's field.
- **Antennas**

AUX1 or Internal antenna
- **Selected Antenna**

Choice between selected antennas
- **RSSI Filters**

To optimize RFID reading, writing and inventory. Tags within the set distance are affected. Min RSSI value means that tag replay signal needs to be equal or stronger than the defined value. Otherwise, tag is not read. Max RSSI value in other hand means that signal strength must be lower than the filter value.
- **Timeouts**

The duration the system waits for function:
  - Kill Tag
  - Lock Tag
  - Read Tag
  - Write Tag
to be carried out.
- **Channel Hopping Event**

Enable or disable channel hop event.
- **Report Zero Count Inventory**

Enable or disable reporting for zero tag rounds.

## 4.7. SOFTWARE

In this section you can update the operative system of the device, but also manage applications and plugins.

### SYSTEM PLUGINS

A plugin in IRX200 is a service that runs internally in the device to enable certain features.

You can manually install plugins or versions of installed plugins and uninstall the installed plugins using this interface.

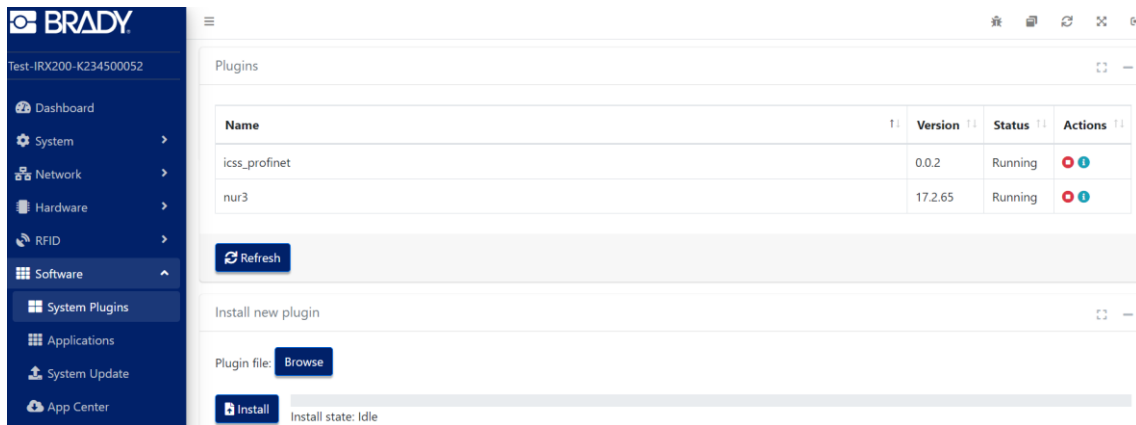

Figure 38: System plugins view.

- **Plugins** List of installed plugins. From Actions, stop plugin, view info or uninstall plugin.
- **Install new plugin** Browse for plugin file and install.

### 4.7.1. PLUGINS AND APPLICATIONS CREDENTIALS

For plugins or applications that need credentials to work, you can create a specific password from System Plugins or Applications.

Go to the plugin or application that needs credentials and click the “Show info” button from Actions. From the application window that opens, click the “New Password” button.

A message will appear indicating the username and the created password (see figure 39).

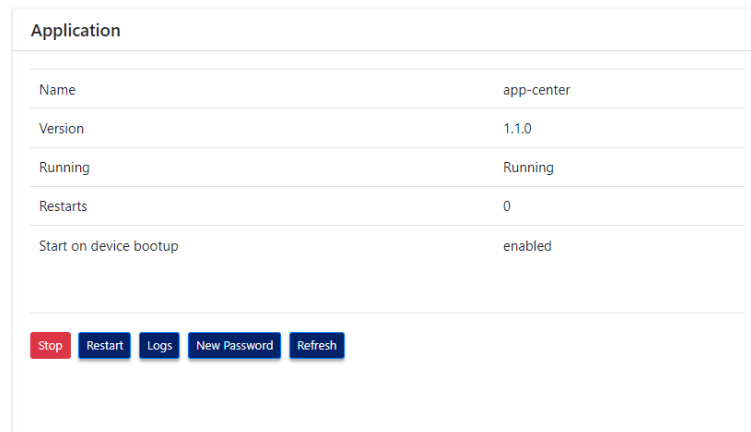

Figure 39: Action buttons for installed plugins an applications

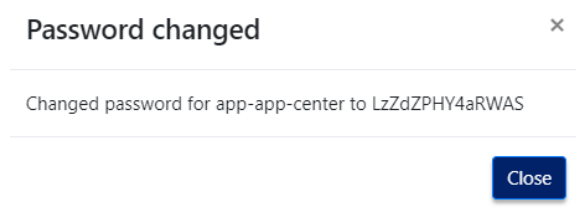

Figure 40: Message indicating the username and the new password created

The username is the internal app or plugin name (e.g., *app-webssh*) and the password is randomly generated (e.g. *W9a4hPlmCsxF*).

## APPLICATIONS

An application in the Brady IRX200 can be any application that you develop for your customers, or an application provided by Brady to help during your development and implementation process.

Not all the applications have a user interface. For example, an application can just read the data from RFID tags, consolidate data, add additional information such as location or timestamp, and send it to a server in the cloud.

Other applications do have an interface. For example, the SSH terminal.

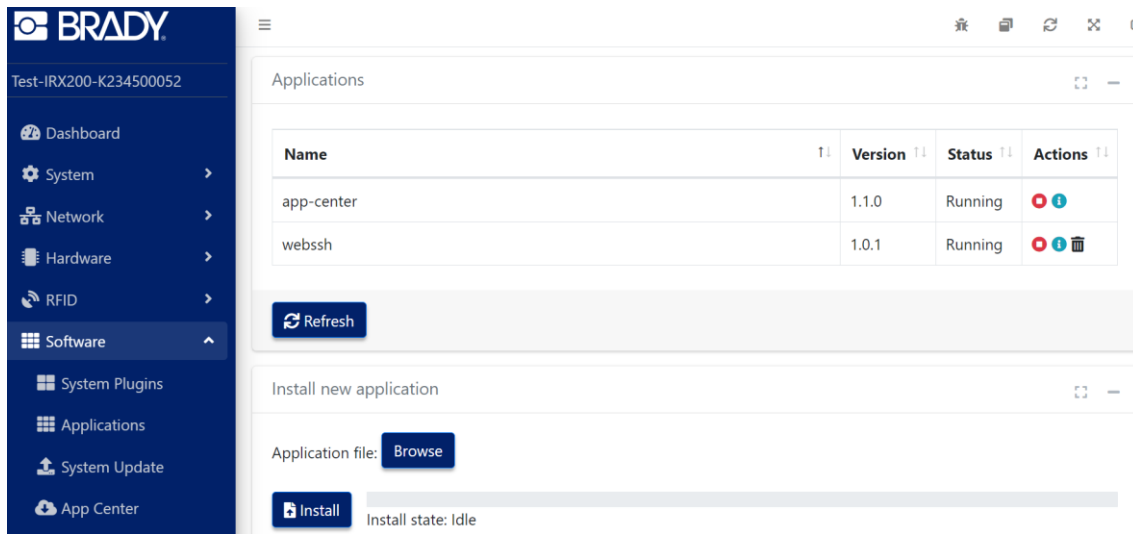

Figure 41: Applications view

- Applications List of installed plugins. From Actions, stop application, view info or uninstall application.
- Install new application Browse for application and install.

## SYSTEM UPDATE

Firmware update.

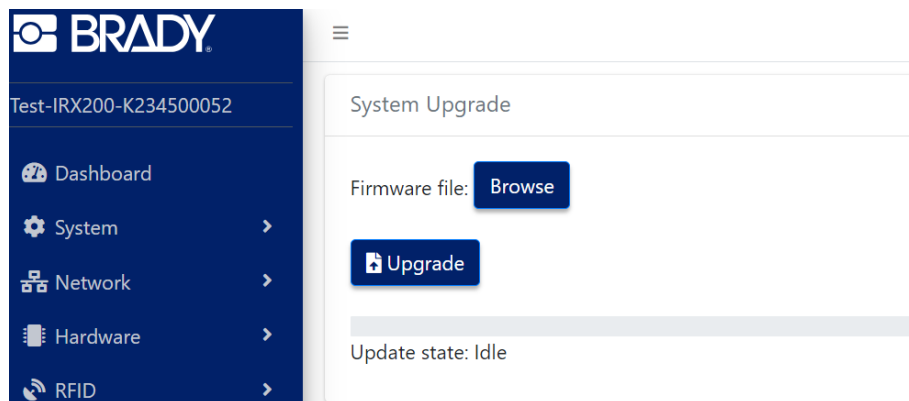

Figure 42: System update view

- Browse Browse for Firmware file
- Upgrade Start upgrade.

## APP CENTER

A repository of selected applications and plugins for the IRX200 to install or update them. With the App Center, the administrator has full control of the available repositories and can add new ones to extend the number of available apps.

Advanced users can also create their own app repository and upload their own apps, to make them accessible and distribute updates. Also, firmware updates can be included in this repository as plugins, in case that specific versions (and not always the latest one) are required.

Instructions to create a Nordic ID App Center repository for the IRX200 can be found here [https://github.com/NordicID/fr22\\_samples](https://github.com/NordicID/fr22_samples)

Note that although the Nordic ID App Center includes new versions of installed apps or firmware, these won't be updated automatically. A manual update is always required.

If automatic updates or installations are needed, 3rd party MDM/EMM (Mobile Device Management / Enterprise Mobility Management) platforms must be used.

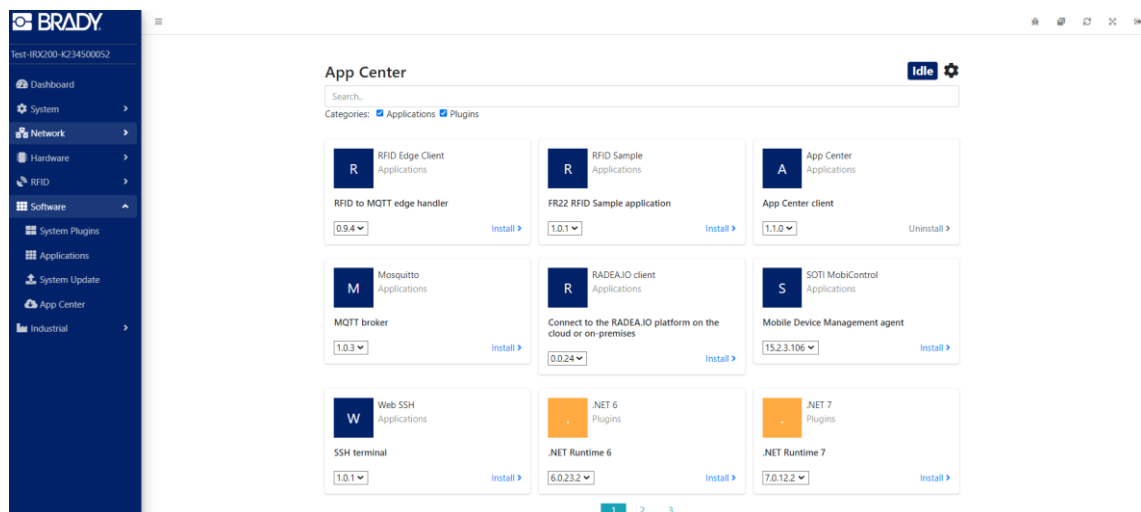

Figure 43: App Center view

- Search Search App Center
- Active status Status can be Idle, Download, Install. Hover over button shows current status.

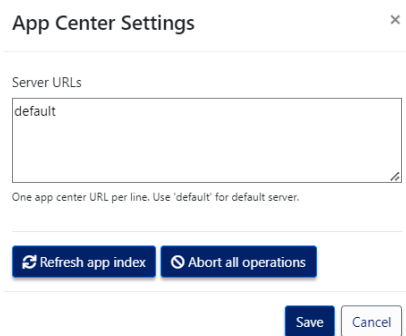

Figure 44: App Center Settings

- **Server URLs** The URL of the application repository
- **Function buttons** Refresh app index refreshes the application view.  
Abort all operations stops all ongoing operations.

## 4.8. INDUSTRIAL

Here you can change the device's operating mode.

### PROTOCOL

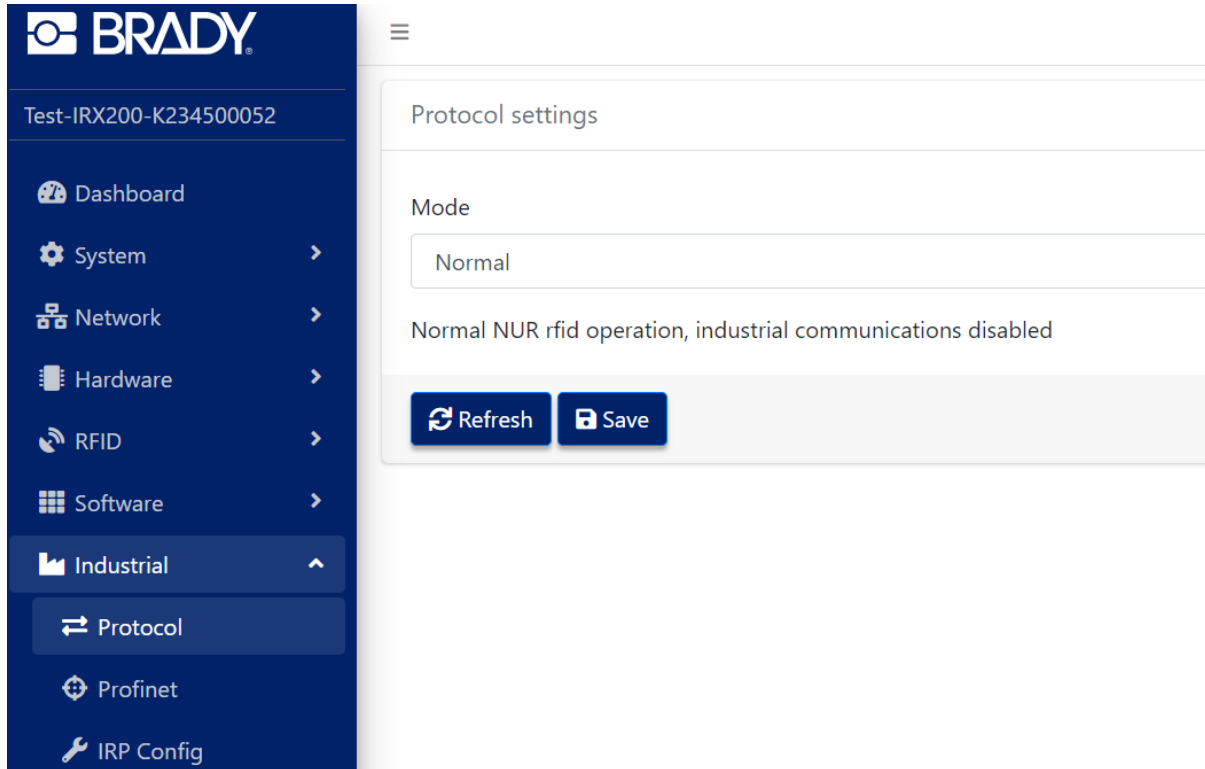

Figure 45: Protocol Settings

- Protocol settings

Choose operating mode from the dropdown. Note that reboot of the device is needed before a new selection becomes active. While operating mode is PROFINET, a PROFINET specific sub-page appears under the Menu -> Industrial.

To read more about operating the IRX200 in PROFINET mode, see the guide BRADY IRX200, Getting started with PROFINET available at [www.brady.eu/all-downloads#4293928306](http://www.brady.eu/all-downloads#4293928306).



## 5. DEVICE API'S AND CUSTOM SOFTWARE DEVELOPMENT

All documentation about software and application development can be found from Nordic ID GitHub from [https://github.com/NordicID/fr22\\_samples](https://github.com/NordicID/fr22_samples)

### 5.1. SYSTEM RPC API

The system API functions are listed in the System tab under API Docs, (see section 4.3). They provide detailed information about the API's functionalities, including the available endpoints.

The offered platforms are:

C/C++ SDK

C# .NET SDK

Rust

Python

For samples and documentation, contact [support@nordicid.com](mailto:support@nordicid.com).

### 5.2. NUR API

NurAPI stands for Nordic ID's Universal RFID Application Programming Interface. Developed by Nordic ID, NurAPI facilitates communication between RFID readers and the software applications that manage the data collected from RFID tags. The API is designed to be both flexible and easy to integrate, making it a versatile tool for developers.

The SDK files for different platforms can be found from [https://github.com/NordicID/nur\\_sdk](https://github.com/NordicID/nur_sdk)

The offered platforms are:

C/C++ SDK

C# .NET SDK

JAVA SDK

Embedded MCU

For samples and documentation, see the corresponding platform folder.

### 5.3. APPLICATION PACKAGING AND SIGNING

Instructions on developing your own applications, about their packaging and signing can be found from [https://github.com/NordicID/fr22\\_samples](https://github.com/NordicID/fr22_samples).

## 6. COMPLIANCE STATEMENTS

### 6.1. REGIONAL SETTINGS

Brady UHF RFID readers support operating frequency range between 860 - 960MHz. Some of the readers cover full operating frequency band and some of them have two sub bands that are

- 868 ETSI band (865.6 - 867.6 MHz)
- 915 FCC band (902 - 928 MHz).

Regional organizations such as ETSI and FCC have set rules and requirements for operating frequencies, output power and other RF parameters for the UHF RFID readers to comply with local regional requirements.

A set of regional settings have been created in order to fulfill local regulations. Brady is required to ensure that the compliance of Brady ID products remains after production. A solution to this is that products including UHF RFID functionality will be set and locked to a region in production, based on customer order. For example, if a product is ordered to Europe, it will be locked to ETSI region and if a product is ordered to Australia, then it is locked to the Australia region. When a product is locked to an individual region, it will comply with local regulations of that region.

### 6.2. CE

Hereby, Nordic ID, a Brady Company, declares that this device is in compliance with the essential requirements and other relevant provisions of:

- RED: 2014/53/EU
- RoHS: 2011/65/EU

Additionally, IRX200 accessories are in compliance with the essential requirements and other relevant provisions of:

- EMC: 2014/30/EU
- LVD: 2014/35/EU
- RoHS: 2011/65/EU

### 6.3. FCC/IC

The Brady RFID device complies with Part 15 of the FCC Rules. Operation is subject to the following two conditions:

- (1) This device may not cause harmful interference, and
- (2) This device must accept any interference received, including interference that may cause undesired operation.

*WARNING: Changes or modifications not expressly approved by the party responsible for compliance could void the user's authority to operate the equipment.*

The IRX200 device contains license-exempt transmitter(s)/receiver(s) that comply with Innovation, Science and Economic Development Canada's license-exempt RSS(s). Operation is subject to the following two conditions:

- (1) This device may not cause interference.
- (2) This device must accept any interference, including interference that may cause undesired operation of the device.

L'émetteur/récepteur exempt de licence contenu dans le présent appareil est conforme aux CNR d'Innovation, Sciences et Développement économique Canada applicables aux appareils radio exempts de licence. L'exploitation est autorisée aux deux conditions suivantes:

- 1) L'appareil ne doit pas produire de brouillage;
- 2) L'appareil doit accepter tout brouillage radioélectrique subi, même si le brouillage est susceptible d'en compromettre le fonctionnement.

## 6.4. RF EXPOSURE

This equipment complies with EU, FCC and IC's RF radiation exposure limits set forth for an uncontrolled environment under the following conditions:

The IRX200 device should be installed and operated such that a minimum separation distance of 30,1cm/12 inch is maintained between the antenna and user's/nearby person's body at all times.

IRX200 doit être installé et utilisé de manière à ce qu'une distance de séparation minimale de 30,1cm/12 inch soit maintenue à tout moment entre l'antenne et le corps de l'utilisateur / de la personne proche.

## 7. SERVICE AND SUPPORT

For technical enquiries regarding Brady devices or software development, please contact our Technical Support:

E-mail: [tseurope@bradycorp.com](mailto:tseurope@bradycorp.com)  
Telephone: +44 333 333 1111

As a manufacturer, Brady stands responsible for providing repair services for its devices during and after the warranty period. Together with partners Brady serves customers globally. When your Brady device needs repair, always use Brady Service or our authorized service partners. We want to make sure that your Brady product serves you the best possible way, and by using our preferred service partners the quality of the service is trustworthy and the spare parts are original. This way the existing product warranty remains, and you receive a 3-month service warranty for the repaired devices.

Brady works together with full support and primary support partners. Full support partners can handle both warranty and non-warranty repairs on behalf of Brady in their own regions. In addition, Brady has a network of smaller repair centers, primary support partners, who offer the first line of support to their customers locally.

For any enquiries about Brady repair service please contact:

E-mail: [tseurope@bradycorp.com](mailto:tseurope@bradycorp.com)  
Telephone: +44 333 333 1111

## 8. WARRANTY

Our products are sold with the understanding that the buyer will test them in actual use and determine for themselves the adaptability to their intended uses. Brady warrants to the buyer that its products are free from defects in material and workmanship but limits its obligation under this warranty to replacement of the product shown to Brady's satisfaction to have been defective at the time Brady sold it. This warranty does not extend to any persons obtaining the product from the buyer.

THIS WARRANTY IS IN LIEU OF ANY OTHER WARRANTY, EXPRESS OR IMPLIED, INCLUDING, BUT NOT LIMITED TO, ANY IMPLIED WARRANTY OF MERCHANTABILITY OR FITNESS FOR A PARTICULAR PURPOSE, AND OF ANY OTHER OBLIGATIONS OR LIABILITY ON BRADY'S PART. UNDER NO CIRCUMSTANCES WILL BRADY BE LIABLE FOR ANY LOSS, DAMAGE, EXPENSE OR CONSEQUENTIAL DAMAGES OF ANY KIND ARISING IN CONNECTION WITH THE USE, OR INABILITY TO USE, BRADY'S PRODUCTS.

## 9. VERSION HISTORY

<b><u>Version</u></b>	<b><u>Date</u></b>	<b><u>Modifications</u></b>
<b><u>0.1</u></b>	<b><u>12/2023</u></b>	<b><u>DRAFT</u></b>
<b><u>1.0</u></b>	<b><u>04/2024</u></b>	<b><u>First version</u></b>
<b><u>1.1</u></b>	<b><u>05/2024</u></b>	<b><u>Fixes to figures</u></b>